

MOTIONS 2006

- 01-06 MOTION TO APPOINT MR. GLANCY CHAIRMAN.
- 02-06 MOTION TO APPOINT MR. PIROS VICE CHAIRMAN.
- 03-06 MOTION TO SET DATES & TIMES OF TRUSTEES MTGS.
- 04-06 MOTION TO EMPLOY DEPT. HEADS AS LISTED.
- 05-06 MOTION TO EMPLOY TWP. EMPLOYEES AS LISTED.
- 06-06 MOTION TO SET ZONING DAYS & HRS.
- 07-06 MOTION TO CONTINUE W/ATT'Y MARK FINAMORE AS LEGAL COUNSEL.
- 08-06 MOTION TO APPROVE PURCHASE ORDERS FOR UNIFORM ALLOWANCE, FUEL, MAINT. CONTRACT & EMS BILLING & SUPPLIES.
- 09-06 MOTION TO APPROVE BLANKET CERTIFICATES FOR USUAL EXPENDITURES.
- 10-06 MOTION TO AUTHORIZE FISCAL OFFICER TO INVEST EXCESS MONEY IN MARKET ACCT., STAR OHIO & SAVINGS WHEN AVAILABLE.
- 11-06 MOTION TO ACCEPT DONATIONS WHEN RECEIVED.
- 12-06 MOTION TO AUTHORIZE PAYMENT OF COSTS FOR TRUSTEES & FISCAL OFFICER'S ATTENDANCE AT MO. TRUM. TWP. ASSOC. MTGS.
- 13-06 MOTION TO AUTHORIZE THE MEMBERSHIP INTO THE OHIO TWP. ASSOC. & ATTENDANCE AT THE ANNUAL ST. ASSOC. CONFERENCE INCLUDING PAYMENT OF EXPENSES FOR THE TRUSTEES AND THE FISCAL OFFICER.
- 14-06 MOTION TO APPROVE THE MIN. OF THE DEC. 19TH MTG.
- 15-06 MOTION TO APPROVE PAYMENT OF BILLS.
- 16-06 MOTION TO APPROVE PURCHASE ORDERS.
- 17-06 MOTION TO CHANGE THE JAN. 16TH MTG. TO JAN. 17TH DUE TO THE HOLIDAY.
- 18-06 MOTION TO GO AHEAD TO INSTALL A LIGHT POLE AT THE INTERSECTION OF WARREN-MEADVILLE RD. AND JOHNSON PLANK.
- 19-06 MOTION TO GO INTO EXECUTIVE SESSION TO DISCUSS NEGOTIATIONS.
- 20-06 MOTION TO ADJOURN THE MTG.
- 21-06 MOTION TO APPROVE THE MIN. OF THE JAN. 04TH MTG.
- 22-06 MOTION TO DONATE UP TO \$450 FOR THE AARON HANSON PROJECT.

- 23-06 MOTION TO APPROVE THE PURCHASE ORDERS.
- 24-06 MOTION TO PAY BILLS.
- 25-06 MOTION TO ADOPT THE RESOLUTION TO PROVIDE POLICE PROTECTION TO OTHER PUBLIC ENTITY.
- 26-06 MOTION TO APPROVE THE REVISED TRUM. CO. MUTUAL AID AGREEMENT EFFECTIVE JANUARY 18, 2006.
- 27-06 MOTION TO ACCEPT THE RENEWAL FROM BEST FURNACE FOR ALL FIVE BLDGS.
- 28-06 MOTION TO PROCEED WITH THE FIRE REWNAL LEVY FOR .08 M.
- 29-06 MOTION TO PROCEED WITH THE POLICE RENEWAL LEVY FOR .06 M.
- 30-06 MOTION TO PROCEED WITH THE POLICE RENEWAL LEVY FOR 1.8 M.
- 31-06 MOTION TO ACCEPT THE IRS CURRENT RATE OF MILEAGE EFFECTIVE JANUARY 01, 2006 TO BE 44.5.
- 32-06 MOTION TO NOMINATE CHAMPION TRUSTEE, TOM TRACY, AS OUR REP. FOR 9-1-1 TECHNICAL ADVISORY BD.
- 33-06 MOTION TO ACCEPT THE HOURLY RATE INCREASE FOR LEGAL COUNSEL, MARK FINAMORE.
- 34-06 MOTION TO AUTHORIZE FISCAL OFFICER TO TRANSFER FROM 09-A-04C TO 09-A-05C \$4,500.
- 35-06 MOTION TO AUTHORIZE FISCAL OFFICER TO ISSUE A P.O. TO AINSLEY OIL FOR \$19,200 FOR THREE MONTHS.
- 36-06 MOTION TO ADJOURN THE MTG.
- 37-06 MOTION TO APPROVE THE MIN. OF THE JAN. 17TH MTG.
- 38-06 MOTION TO APPROVE PURCHASE ORDERS.
- 39-06 MOTION TO APPROVE THE PAYMENT OF BILLS.
- 40-06 MOTION TO APPROVE 2 MOSQUITO SPRAYS.
- 41-06 MOTION TO APPROVE THE SERVICE AGREEMENT FOR THE POLICE DEPT. MOBILE DATA TERMINALS.
- 42-06 MOTION TO GRANT A 1% RAISE TO CHIEF MCKENZIE, CHIEF SAYERS AND ADMIN. SEC'Y ROBYN METHENY.
- 43-06 MOTION TO PURCHASE 10 TIRES FROM HOVIS TIRE FOR TWO SQUADES.
- 44-06 MOTION TO PURCHASE A LAPTOP COMPUTER FOR SQUAD EMS REPORTS FROM DELL.
- 45-06 MOTION TO KEEP SAME PRICES AS LAST YEAR FOR SPRING CLEAN UP.

- 46-06 MOTION TO PROCEED WITH THE SECOND READING OF THE POLICE RENEWAL LEVY FOR .06M TO BE PLACED ON THE MAY 02ND BALLOT.
- 47-06 MOTION TO PROCEED WITH THE SECOND READING OF THE POLICE RENEWAL LEVY FOR 1.8M TO BE PLACED ON THE MAY 02ND BALLOT.
- 48-06 MOTION TO PROCEED WITH THE SECOND READING OF THE FIRE RENEWAL LEVY FOR 0.8M TO BE PLACED ON THE MAY 02ND BALLOT.
- 49-06 MOTION TO AUTHORIZE THE FISCAL OFFICER TO TRANSFER WITHIN FUNDS TO PAY INS. LIABILITY ON VEHICLES AND BUILDINGS TO OTRAMA.
- 50-06 MOTION TO AUTHORIZE THE FISCAL OFFICER TO TRANSFER WITHIN FUNDS TO PAY THE CONTRACT WITH BEST FURNACE.
- 51-06 MOTION TO ACCEPT THE AMOUNT OF RATES AS DETERMINED BY THE BUDGET COMMISSION AND AUTHORIZING THE NECESSARY TAX LEVIES AND CERTIFYING THEM TO THE CO. AUDITOR.
- 52-06 MOTION TO ACCEPT THE PARK BOARD 2006 BUDGET OF \$17,000.00.
- 53-06 MOTION TO ADJOURN THE MTG.
- 54-06 MOTION TO SOLICIT A PROPOSAL FROM JAKUBICK.
- 55-06 MOTION TO APPROVE THE MIN. OF THE FEB. 06TH MTG.
- 56-06 MOTION TO APPROVE THE P.O.'S.
- 57-06 MOTION TO APPROVE PAYMENT OF BILLS.
- 58-06 MOTION TO HIRE SOMEONE TO DEMOLISH THE PROPERTY AT 3054 NORTH PARK.
- 59-06 MOTION TO RETAIN TWP. RECORDS INDEFINITELY AT THIS TIME.
- 60-06 MOTION TO AUTHORIZE THE FISCAL OFFICER TO TRANSFER WITHIN FUNDS.
- 61-06 MOTION TO AMEND RESOLUTION 310-05.
- 62-06 MOTION TO MAKE A P.O. OUT FOR 9-1-1 TO COVER JAN. & FEB.
- 63-06 MOTION TO PURCHASE A NEW DRUM FOR THE ADMIN. COPIER.
- 64-06 MOTION TO ACCEPT QUOTE FOR 2,800 BLACK & WHITE FLYERS.
- 65-06 MOTION TO ADJOURN THE MTG.
- 66-06 MOTION TO APPROVE MIN. OF THE FEB. 21ST MTG.
- 67-06 MOTION TO APPROVE PURCHASE ORDERS.
- 68-06 MOTION TO APPROVE PAYMENT OF BILLS.

- 69-06 MOTION TO ACCEPT THE BID FROM SUNBURST FOR CLEAN UP DAY.
- 70-06 MOTION TO APPROVE THE DONATION OF \$300 FOR THE EASTER EGG HUNT
- 71-06 MOTION TO APPROVE POSTAL MAIL SORT TO MAIL OUT THE SPRING BLYER.
- 72-06 MOTION TO AUTHORIZE THE FISCAL OFFICER TO TRANSFER WITHIN FUNDS.
- 73-06 MOTION TO ADJOURN THE MTG.
- 74-06 MOTION TO APPROVE MIN. OF THE MARCH 06TH MTG.
- 75-06 MOTION TO APPROVE PURCHASE ORDERS.
- 76-06 MOTION TO APPROVE PAYMENT OF BILLS.
- 77-06 MOTION TO ADOPT PERMANENT APPROPRIATIONS.
- 78-06 MOTION TO AUTHORIZE FISCAL OFFICER TO TRANSFER MONIES.
- 79-06 MOTION TO APPROVE THE INVOICE FROM TRUM. SOIL AND WATER CONSERVATION DIST. FOR 2006 CONSERVATION APPROPRIATION.
- 80-06 MOTION TO APPOINT MARK FRANKO AND TODD MCCART AS ALTERNATE BOARD MEMBERS FOR THE ZONING COMMISSION BOARD.
- 81-06 MOTION TO ADJOURN THE MTG.
- 82-06 MOTION TO PURCHASE TWO USED RADAR UNITS FROM MIDWEST RADAR
- 83-06 MOTION TO PURCHASE 12 IMPACT PLATES FOR BULLETPROOF VESTS FROM RED DIAMOND.
- 84-06 MOTION TO PURCHASE EVIDENCE ROOM SOFTWARE & BARCODE EQUIPMENT FROM TOTAL SOLUTIONS.
- 85-06 MOTION TO PURCHASE THROUGH STATE PURCHASING A 2006 FORD E350 SUPER SUTY XL CITIMEDIC 138 WHEELED COACH EMERGENCY VEHICLE.
- 86-06 MOTION TO SIGN A LETTER IN SUPPORT OF HOUSE BILL 401.
- 87-06 MOTION TO REHIRE JACK GOVERNOR AS PART-TIME SUMMER HELP.
- 88-06 MOTION TO ACCEPT THE BID FROM Z-TECH BUILDERS & EXCAVATORS FOR THE DEMOLITION OF 3054 NORTH PARK AVE.
- 89-06 MOTION TO TRANSFER \$500 FROM 05-A-07 TO 05-A-09
- 90-06 MOTION TO APPROVE MIN. OF THE MARCH 20TH MTG.
- 91-06 MOTION TO APPROVE PURCHASE ORDERS.
- 92-06 MOTION TO APPROVE PAYMENT OF BILLS.
- 93-06 MOTION TO ADJOURN THE MTG.

APRIL 17, 2006

- 94-06 MOTION TO APPROVE THE APRIL 03RD MINUTES.
- 95-06 MOTION TO APPROVE PURCHASE ORDERS.
- 96-06 MOTION TO APPROVE PAYMENT OF BILLS.
- 97-06 MOTION TO APPROVE THE ZONE CHANGE FOR 2489 NILES-CORTLAND ROAD FROM RESIDENTIAL TO COMMERCIAL.
- 98-06 MOTION TO ACCEPT THE QUOTES FROM THE TRUM. CO. ENGINEER'S OFFICE FOR STRIPING AND TO SWEEP ALL TWP. RDS.
- 99-06 MOTION TO ACCEPT THE DRAWINGS TO RUN ELECTRIC TO THE GAZEBO.
- 100-06 MOTION TO ACCEPT THE BID FROM CALHOUN CRETE TO BUILD THE RAMP FOR THE GAZEBO.
- 101-06 MOTION TO AUTHORIZE THE FISCAL OFFICER TO TRANSFER FUNDS FROM 10A-01 TO 10-A-10.
- 102-06 MOTION TO ACCEPT THE QUOTE FROM HOWLAND PRINTING FOR THE TWP. ZONING MANUAL.
- 103-06 MOTION TO CONTINUE WITH CORVEL, OUR MANAGED-CARE ORGANIZATION TO RUN THROUGH MAY OF 2007.
- 104-06 MOTION TO INCREASE THE BID FROM Z-TECH TO \$2,900 CONCERNING THE DWELLING AT 3054 NORTH PARK.
- 105-06 MOTION TO HIRE JASON KORPON AT \$9.50 PER HOUR AS PART-TIME FIREMAN/EMT.
- 106-06 MOTION TO ACCEPT THE STATEMENT OF PROFESSIONAL DESIGN SERVICE QUALIFICATIONS FROM JAKUBICK/SEXTON.
- 107-06 MOTION TO ADJOURN THE MTG.

MAY 01, 2006

- 108-06 MOTION TO APPROVE THE MIN. OF THE APRIL 17TH MTG.
- 109-06 MOTION TO APPROVE PURCHASE ORDERS.
- 110-06 MOTION TO APPROVE PAYMENT OF BILLS.
- 111-06 MOTION TO APPROVE TEMPORARY PROMOTION OF MIKE HOVIS TO SGT. EFFECTIVE MAY 01, 2006 AT A RATE OF \$20.81 PLUS LONGEVITY.
- 112-06 MOTION TO APPROVE THE NEW CHANGES IN THE COST RECOVERY PRICES FOR THE FIRE, POLICE AND RD. DEPT.
- 113-06 MOTION TO HIRE PART-TIME FIREFIGHTER/MEDIC PATRICK DALES TO START MAY 08, 2006.

- 114-06 MOTION TO APPROVE THE RE-TYPED ZONING MANUAL.
- 115-06 MOTION TO APPROVE THE PAYMENT OF \$60 TO THE TRUM. CO. RECORDER'S OFFICE TO FILE 6 NEW OR REVISED PAGES TO THE NEW ZONING MANUAL.
- 116-06 MOTION TO AUTHQRIZE THE FISCAL OFFICER TO TRANSFER WITHIN FUNDS FROM 05-A-02A TO 05-A-12.
- 117-06 MOTION TO OPPOSE THE TEL/TABOR AMENDMENT ON THE NOV. 2006 BALLOT.

118-06 MOTION TO ADJOURN THE MTG.

MAY 15, 2006

- 119-06 MOTION TO APPROVE THE MIN. OF THE MAY 01ST. MTG.
- 120-06 MOTION TO APPROVE PURCHASE ORDERS.
- 121-06 MOTION TO APPROVE PAYMENT OF BILLS.
- 122-06 MOTION TO APPROVE THE PUR. OF 2 LAP TOPS FOR POL. DEPT. FROM DELL.
- 123-06 MOTION TO APPROVE SPENDING OF \$270 FOR POL. DEPT. TO HAVE A BOOTH AT THE TRUM. CO. FAIR.
- 124-06 MOTION TO INCREASE THE PRICE OF THE ZONING BOOK TO \$10.
- 125-06 MOTION TO INCREASE ORIGINAL BID FROM Z-TECH TO INCLUDE THE ADDITIONAL \$50 PERMIT NEEDED TO DO THE DEMOLITION OF 3054 NORTH PARK AVE.
- 126-06 MOTION TO APPROVE THE PUR. OF 12 5X8 NYLON US FLAGS.
- 127-06 MOTION TO TRANSFER WITHIN FUNDS 05-A-02 CEMETERY TO 05-A-01 CEMETERY.
- 128-06 MOTION TO ADJOURN THE MTG.

JUNE 05, 2006

- 129-06 MOTION TO APPROVE MIN. OF THE MAY 15TH MTG.
- 130-06 MOTION TO APPROVE PURCHASE ORDERS.
- 131-06 MOTION TO APPROVE PAYMENT OF BILLS.
- 132-06 MOTION TO ACCEPT THE QUOTE FROM BAZETTA TREE FOR \$815.
- 133-06 MOTION TO AUTHORIZE THE FISCAL OFFICER TO TRANSFER WITHIN FUNDS.
- 134-06 MOTION TO PURCHASE A RE-CONDITIONED PAYMASTER RIBBON CHECK SIGNER FOR \$300.
- 135-06 MOTION TO PAY @TARMA AN ADDITIONAL \$5,464.

JUNE 05, 2006

- 136-06 MOTION TO APPROVE THE RE-ZONING OF 3372 ST. RT. 5 FROM RESIDENTIAL R-1 TO COMMERCIAL C-1.
- 137-06 MOTION TO APPROVE THE SPENDING OF \$525 TO VENTLING MEMORIALS FOR THE WAGNER/SPARHAEK CEMETERY STONE REPAIR.
- 138-06 MOTION TO ACCEPT THE BID FROM DEAN'S FENCE FOR \$480 TO REPAIR THE FENCE AT THE HILLSIDE CEMETERY.
- 139-06 MOTION TO ACCEPT THE BID SHEET PREPARED BY MARTHA.
- 140-06 MOTION TO ADJOURN THE MTG.

JUNE 19, 2006

- 141-06 MOTION TO ELECT JEFF BATES TO SERVE AS CHAIRMAN.
- 142-06 MOTION TO HAVE ATT'Y FINAMORE TO SEND OUT A LETTER NOTICE TO THE RESIDENCE AT 3723 HOAGLAND BLACKSTUB ROAD OF THE VIOLATION UNDER OHIO REVISED CODE 50587.
- 143-06 MOTION TO APPROVE THE MIN. OF THE JUNE 05TH MTG. WITH CORRECTIONS.
- 144-06 MOTION TO APPROVE PURCHASE ORDERS.
- 145-06 MOTION TO APPROVE PAYMENT OF BILLS.
- 146-06 MOTION TO TABLE THE MATTER CONCERNING THE SIDEWALK EXTENSION IN FRONT OF THE HILLSIDE CEMETERY.
- 147-06 MOTION TO SEND OUT ANOTHER NOTICE OF THE CEMETERY RULES TO THE MONUMENT COMPANIES.
- 148-06 MOTION TO AUTHORIZE THE EXPENDITURE OF \$1,097.78 TO THE 717 CREDIT UNION TO RELEASE A LIEN ON A FORFEITED VEHICLE.
- 149-06 MOTION TO SET UP A MTG. WITH THE PARK BOARD & THE TRUSTEES TO DISCUSS POSSIBLY REQUESTING A DEPOSIT TO USE THE PARK.
- 150-06 MOTION TO START WITH THE FIRST MTG. IN AUGUST TO USE THE TAPE RECORDER FOR TRUSTEE MTGS.
- 151-06 MOTION TO ACCEPT THE FACT FINDER REPORT.
- 152-06 MOTION TO GO INTO EXECUTIVE SESSION TO DISCUSS POSSIBLE EMPLOYEE DISCIPLINE IN THE POL. DEPT.
- 153-06 MOTION TO ADJOURN THE MTG.

JULY 03, 2006

- 154-06 MOTION TO APPROVE THE MIN. OF THE JUNE 19TH MTG.

- 155-06 MOTION TO APPROVE PURCHASE ORDERS.
- 156-06 MOTION TO APPROVE THE PAYMENT OF BILLS.
- 157-06 MOTION TO TABLE THE MATTER OF SENDING POLICE OFFICERS TO CONTINUING PROFESSIONAL TRAINING.
- 158-06 MOTION TO SEND CHIEF SAYERS TO THE PARTNERS IN PREPAREDNESS CONFERENCE.
- 159-06 MOTION TO SEND CHIEF SAYERS TO A ONE-DAY WORKSHOP ENTITLED "INTERNET SAFETY - TRAIN THE TRAINER"
- 160-06 MOTION TO AUTHORIZE THE FISCAL OFFICER TO TRANSFER MONIES WITHIN FUNDS.
- 161-06 MOTION TO AUTHORIZE THE FISCAL OFFICER TO TRANSFER MONIES.
- 162-06 MOTION TO AUTHORIZE THE FISCAL OFFICER TO REQUEST A NEW "CERTIFICATE OF ESTIMATED RESOURCES".
- 163-06 MOTION TO ADJOURN THE MTG.
(July 17, 2006)
- 164-06 MOTION TO APPROVE THE MIN. OF THE JULY 03RD MTG.
- 165-06 MOTION TO APPROVE THE PURCHASE ORDERS.
- 166-06 MOTION TO APPROVE THE PAYMENT OF BILLS.
- 167-06 MOTION TO TRANSFER FROM 09-A-14 TO 09-A-03.
(\$14,054.73 FOR BWC)
- 168-06 MOTION TO PROCEED WITH THE DEMOLITION OF THE STRUCTURE AT 3054 NORTH PARK AVENUE.
- 169-06 MOTION TO PAY \$100 TO CO-OPERATIVE PURCHASING PROGRAM.
- 170-06 MOTION TO APPROVE THE ALTERNATIVE TAX BUDGET.
- 171-06 MOTION TO SET TRICK OR TREAT NIGHT FOR TUES., OCT. 31ST FROM 6-8 PM.
- AUGUST 07, 2006
- 172-06 MOTION TO GO INTO EXECUTIVE SESSION FOR THE POL. DEPT.
- 173-06 MOTION TO ADJOURN THE MTG.
- 174-06 MOTION THAT THE TRUSTEES PAY 10% OF THEIR HEALTH CARE.
- 175-06 MOTION TO APPROVE THE MIN. OF THE JULY 17TH MTG.
- 176-06 MOTION TO APPROVE PURCHASE ORDERS.
- 177-06 MOTION TO APPROVE PAYMENT OF BILLS.

AUGUST 07, 2006

178-06 MOTION TO ALLOCATE 31% OF NEXT YEARS LOCAL GOVERNMENT SHARE OF ISSUE II MONIES.

179-06 MOTION TO ACCEPT THE DONATION OF THREE USED MOBILE DATA TERMINALS (MDT) FROM AKRON POLICE DEPT.

180-06 MOTION TO CHANGE SEPT. 04TH MTG. DATE TO TUESDAY, SEPTEMBER 05TH DUE TO THE HOLIDAY.

181-06 MOTION TO HAVE HOWLAND PRINTING TO PRINT 2,800 FALL FLYERS AT A COST OF \$598.

182-06 MOTION TO HAVE POSTAL MAIL SORT MAIL OUT 2,251 FALL FLYERS TO REGISTERED VOTERS AT A COST OF \$548.35.

183-06 MOTION TO TABLE THE DISCUSSION ON THE TIMBER CREEK STREET LIGHTING PROJECT.

184-06 MOTION TO AUTHORIZE THE FISCAL OFFICER TO TRANSFER FUNDS WITHIN THE CEMETERY FUND.

185-06 MOTION TO ADJOURN THE MTG.

AUGUST 21, 2006

186-06 MOTION TO AUTHORIZE THE FISCAL OFFICER TO TRANSFER WITHIN FUNDS.

187-06 MOTION TO AUTHORIZE THE FISCAL OFFICER TO REQUEST An AMENDED CERTIFICATE OF ESTIMATED RESOURCES FROM THE TRUM. CO. AUDITOR.

188-06 MOTION TO APPROVE THE MINUTES OF THE AUGUST 07TH MTG.

189-06 MOTION TO APPROVE PURCHASE ORDERS.

190-06 MOTION FOR TRUSTEE PIROS TO WRITE A LETTER TO EAGLE SCOUT AARON HANSON.

191-06 MOTION TO APPROVE PAYMENT OF BILLS.

192-06 MOTION TO TABLE DISCUSSION ON THE VIEW OBSTRUCTION AT THE INTERSECTION OF CADWALLADER-SONK RD. AND MCCLEARY JACOBY RD.

193-06 MOTION TO RESCIND RESOLUTION 150-06.

194-06 MOTION TO PAY CROSBY-MOOK FOR THE COPIER MAINT. AGREEMENT FOR THE P.D.

195-06 MOTION TO ACCEPT THE CUSTODIAN'S CONTRACT FOR ONE YEAR.

196-06 MOTION TO PAY WORKERS' COMPENSATION THE SECOND HALF PREMIUM OF \$26,399.52

197-06 MOTION TO GO INTO EXECUTIVE SESSION AT 7:56 PM TO DISCUSS POSSIBLE EMPLOYEE DISCIPLINE IN THE P.D.

- 198-06 MOTION TO ADJOURN THE MTG. AT 8:15 PM.
(09-05-06)
- 199-06 MOTION TO APPROVE TRUSTEE BATES TO TRAVEL TO DAYTON TO ATTEND A BWC TRAINING CLASS.
- 200-06 MOTION TO APPROVE THE MIN. OF THE AUGUST 21ST MTG.
- 201-06 MOTION TO APPROVE THE PURCHASE ORDERS.
- 202-06 MOTION TO APPROVE PAYMENT OF BILLS.
- 203-06 MOTION TO PERMANENTLY PROMOTE MIKE HOVIS TO SERGEANT.
- 204-06 MOTION TO AUTHORIZE THE FISCAL OFFICER TO TRANSFER WITHIN FUNDS.
- 205-06 MOTION TO TABLE THE LEGAL FEE CONTRACT WITH MARK FINAMORE.
- 206-06 MOTION TO ACCEPT THE UPDATED CELL PHONE POLICY.
- 207-06 MOTION TO ENDORSE CANDIDATES.
- 208-06 MOTION TO ADJOURN THE MTG.
- (09-18-06)
- 209-06 MOTION TO AUTHORIZE THE FISCAL OFFICER TO TRANSFER MONEY WITHIN THE LISTED FUNDS.
- 210-06 MOTION TO APPROVE THE MIN. OF THE SEPT. 05TH MTG.
- 211-06 MOTION TO APPROVE PURCHAS ORDERS.
- 212-06 MOTION TO APPROVE THE PAYMENT OF BILLS.
- 213-06 MOTION TO PLACE AN ORDER FOR 700 TONS OF RD. SALT.
- 214-06 MOTION TO SEND 2 RD. DEPT. EMPLOYEES TO A SEMINAR FOR DEALING W/DIFFICULT PEOPLE.
- 215-06 MOTION TO DIRECT ATT'Y FINAMORE TO SEND A LETTER TO THE OWNER OF THE MACKAY PROPERTY CONCERNING THE BRANCHES.
- 216-06 MOTION TO HIRE SHAWN RENTZ AS A FULL-TIME POLICE OFFICER.
- 217-06 MOTION TO APPROVE LANDSCAPING AND THE DRIVEWAY WORK AT THE TWP. PARK.
- 218-06 MOTION TO APPROVE THE CONTRACT W/ATT'Y FINAMORE
- 219-06 MOTION TO APPROVE THE ZONE CHANGE AT 484 WILSON-SHARPSVILLE RD.
- 220-06 MOTION TO APPROVE THE TPA PROFESSIONAL RISK MANAGEMENT WORKERS' COMPENSATION ANNUAL SERVICE FEE.
- 221-06 MOTION TO PURCHASE A 5 DRAWER STEEL FLAT FILE CABINET.
- 222-06 MOTION TO CHANGE ALL TRUSTEE REGULAR MEETINGS TO THE FIRST AND THIRD MONDAYS OF EACH MONTH AT 7:00 PM.

- 223-06 MOTION TO GO INTO EXECUTIVE SESSION TO DISCUSS
POLICE NEGOTIATIONS.
- 224-06 MOTION TO ADJOURN THE MTG.
- (10-02-06)
225-06 MOTION TO AUTHORIZE THE FISCAL OFFICER TO TRANSFER
MONEY WITHIN FUNDS.
- 226-06 MOTION TO ACCEPT THE AMOUNT OF RATES AS DETERMINED BY
THE BUDGET COMMISSION & AUTHORIZING THE NECESSARY TAX
LEVIES & CERTIFYING THEM TO THE TRUM CO. AUDITOR.
- 227-06 MOTION TO APPROVE THE MIN. OF THE SEPT. 18TH MTG.
- 228-06 MOTION TO APPROVE PURCHASE ORDERS.
- 229-06 MOTION TO APPROVE THE PAYMENT OF BILLS.
- 230-06 MOTION TO SEND A LETTER TO L&D MEDICAL TO CANCEL
THEIR CONTRACT WITH THE TWP. AS OF JAN., 2007.
- 231-06 MOTION TO ACCEPT THE QUOTE OF \$16,250.00 FROM HAYCO
REMODELERS INC. FOR REPLACEMENT OF WINDOWS & DOORS
AT STATION #11 AND #13.
- 232-06 MOTION TO PASS A RESOLUTION TO SET THE SPEED LIMIT
ON STONEGATE AT 25 MPH AND TO AUTHORIZE THE STATE TO
INSTALL A "STOP" SIGN ON STONEGATE.
- 233-06 MOTION TO ACCEPT THE QUOTE OF \$690 FROM KINSMAN RENTAL
FOR EQUIPMENT RENTAL (MINI EXCAVATOR) FOR THE PRINCE
DRIVE PROJECT.
- 234-06 MOTION TO DECLARE 460 STATE ROUTE 305 NE A NUISANCE.
- 235-06 MOTION TO ADJOURN THE MTG.
- (10-16-06 MTG.)
236-06 MOTION TO AUTHORIZE THE FISCAL OFFICER TO TRANSFER
MONEY WITHIN FUNDS.
- 237-06 MOTION TO AMEND RESOLUTION #232-04.
- 238-06 MOTION TO HAVE ATT'Y FINAMORE SEND THE PROPERTY OWNER
ANOTHER LETTER CONCERNING THE PROPERTY BEHIND AND
BESIDE 3719 BAZETTA RD.
- 239-06 MOTION TO APPROVE THE MINUTES OF THE OCT. 02ND MTG.
- 240-06 MOTION TO APPROVE PURCHASE ORDERS.
- 241-06 MOTION TO APPROVE THE BILLS WITH THE EXCEPTION OF
CHECK #4682 TO THE CITY OF WARREN.
- 242-06 MOTION TO ACCEPT THE BID FROM HOVIS TIRE FOR 6
GOODYEAR TIRES FOR THE 1988 DUMP TRUCK.
- 243-06 MOTION TO ACCEPT THE INCREASE OF \$2 PER TON A MONTH
FROM GEAUGA-TRUMBULL SOLID WASTE MANAGEMENT DIST.

10-16-06 MTG.

- 244-06 MOTION TO PAY OPERS \$43,766.22 FOR DELINQUENT EMPLOYEE AND EMPLOYER CONTRIBUTIONS.
- 245-06 MOTION TO AUTHORIZE THE FISCAL OFFICER TO ATTEND THE STATE AUDITOR'S FINANCIAL STATEMENT PREP TRAINING PROGRAM.
- 246-06 MOTION TO REJECT ALL BIDS FOR THE TIMBER CREEK HEIGHTS STREET LIGHTING PROJECT.
- 247-06 MOTION TO GO INTO EXECUTIVE SESSION TO DISCUSS POSSIBLE EMPLOYEE DISCIPLINE.
- 248-06 MOTION TO RETURN TO REGULAR SESSION.
- 249-06 MOTION TO ADJOURN THE MTG.

11-06-06 MTG.

- 250-06 MOTION TO AUTHORIZE FISCAL OFFICER TO TRANSFER WITHIN THE FUNDS LISTED.
- 251-06 MOTION TO AUTHORIZE THE FISCAL OFFICER TO TRANSFER WITHIN THE LISTED FUNDS.
- 252-06 MOTION TO AUTHORIZE THE FISCAL OFFICER TO REQUEST AN AMENDED CERTIFICATE OF ESTIMATED RESOURCES.
- 253-06 MOTION TO APPROVE THE MIN. OF THE OCT. 16TH MTG.
- 254-06 MOTION TO APPROVE THE PURCHASE ORDES.
- 255-06 MOTION TO APPROVE PAYMENT OF BILLS.
- 256-06 MOTION TO RESCIND RESOLUTION 231-06 (HAYCO).
- 257-06 MOTION TO DECLARE THE PROPERTY AT 380 STATE ROUTE A NUISANCE.
- 258-06 MOTION TO APPROVE THE CONTRACT WITH THE TEAMSTERS UNION LOCAL 377.
- 259-06 MOTION TO RESCIND RESOLUTION 174-06 (10% HEALTH CARE PAYMENT FROM THE BOARD OF TRUSTEES).
- 260-06 MOTION TO ADJOURN THE MTG.

NOVEMBER 20, 2006

- 261-06 MOTION TO AUTHORIZE ATT'Y FINAMORE TO SEND A LETTER TO HAVE THE GARBAGE & JUNK CARS REMOVED FROM THE MEDZIE PROPERTY.
- 262-06 MOTION TO APPROVE THE MIN. OF THE NOV. 06TH MTG.
- 263-06 MOTION TO APPROVE PURCHASE ORDERS.

NOVEMBER 20, 2006

264-06 MOTION TO APPROVE PAYMENT OF BILLS.

265-06 MOTION TO APPROVE THE AMBULANCE/FIRE SERVICE FEES & CHARGES W/OHIO BILLING.

266-06 MOTION TO APPROVE THE BUSINESS ASSOCIATE AGREEMENT W/OHIO BILLING.

267-06 MOTION TO APPROVE THE SERVICE AGREEMENT W/OHIO BILLING.

268-06 MOTION TO APPROVE THE HIRING OF UCB COLLECTION AGENCY OF CLEVELAND TO COLLECT THE FEES.

269-06 MOTION TO SELL THE OLD HURST RESCUE TOOL.

270-06 MOTION TO APPROVE THE PURCHASE FROM DEXTER CO. AN EXTRA SET OF SNOW PLOW BLADES & BOLTS.

271-06 MOTION TO HAVE THE LOW SPOT ON CADWALLADER-SONK RD. REPAIRED.

272-06 MOTION TO AUTHORIZE THE FISCAL OFFICER TO REQUEST A NEW CERTIFICATE OF ESTIMATED RESOURCES TO REDUCE FUND 14.

273-06 MOTION TO APPROVE THE POLICE DEPT. CONTRACT.

274-06 MOTION TO GO INTO EXECUTIVE SESSION.

275-06 MOTION TO RETURN TO REGULAR SESSION.

276-06 MOTION TO ADJOURN THE MTG.

DECEMBER 04, 2006

277-06 MOTION TO APPROVE TRANSFER OF MONEY.

278-06 MOTION TO APPROVE TRANSFER OF MONEY.

279-06 MOTION TO AUTHORIZE FISCAL OFFICER TO REQUEST AN AMENDED CERTIFICATE OF ESTIMATED RESOURCES.

280-06 MOTION TO APPROVE MIN. OF THE NOV. 20TH MTG.

281-06 MOTION TO JOIN NITTS FOR ONE YR.

282-06 MOTION TO APPROVE PURCHASE ORDERS.

283-06 MOTION TO APPROVE PAYMENT OF BILLS.

284-06 MOTION TO PASS RESOLUTION TO PLACE SNOW BAN IN EFFECT IMMEDIATELY.

285-06 MOTION TO APPROVE PURCHASE OF A STIHL CHAIN SAW.

286-06 MOTION TO COMPLY W/NEW RATES FOR OPERS -- JAN. 01, 2007.

287-06 MOTION TO GO WITH ANTHEM EFFECTIVE JAN. 01, 2007.

- 288-06 MOTION TO AUTHORIZE THE FISCAL OFFICER TO MAKE A PURCHASE ORDER TO THE TEAMSTERS LOCAL 377 FOR \$6,210.
- 289-06 MOTION TO REDUCE CURRENT OPERS PERCENTAGE FROM 9% TO 7% ON FRANK PARKE DUE TO RD. DEPT. CONTRACT.
- 290-06 MOTION TO GO INTO EXECUTIVE SESSION - POSSIBLE EMPLOYEE DISCIPLINE.
- 291-06 MOTION TO RETURN TO REGULAR SESSION.
- 292-06 MOTION TO ADJOURN THE MTG.
DECEMBER 18, 2006
- 293-06 MOTION TO AUTHORIZE THE FISCAL OFFICER TO TRANSFER WITHIN FUNDS.
- 294-06 MOTION TO AUTHORIZE THE FISCAL OFFICER TO REQUEST AN AMENDED CERTIFICATE OF ESTIMATED RESOURCES FROM FIRE FUND 10.
- 295-06 MOTION TO AUTHORIZE THE FISCAL OFFICER TO TRANSFER WITHIN FUNDS.
- 296-06 MOTION TO APPROVE THE MIN. OF THE DEC. 04TH MTG.
- 297-06 MOTION TO APPROVE THE PURCHASE ORDERS.
- 298-06 MOTION TO APPROVE THE PAYMENT OF BILLS.
- 299-06 MOTION TO ACCEPT INVENTORIES.
- 300-06 MOTION TO AUTHORIZE THE FISCAL OFFICER TO REQUEST AN ADVANCE OF 1ST SETTLEMENT OF 2006 PERSONAL PROPERTY TAX.
- 301-06 MOTION TO AUTHORIZE THE FISCAL OFFICER TO REQUEST AN ADVANCE OF 1ST SETTLEMENT OF 2006 REAL ESTATE TAX.
- 302-06 MOTION TO AUTHORIZE THE FISCAL OFFICER TO REQUEST AN ADVANCE 1ST SETTLEMENT OF 2006 INHERITANCE TAX.
- 303-06 MOTION TO ACCEPT THE ANNUAL ODOT MILEAGE CERTIFICATION.
- 304-06 MOTION TO APPOINT PEOPLE LISTED TO THE VOLUNTEER FIRE FIGHTER'S DEPENDENTS FUND BOARD.
- 305-06 MOTION TO GO INTO EXECUTIVE SESSION TO DISCUSS A GRIEVANCE.
- 306-06 MOTION TO RETURN TO REGULAR SESSION.
- 307-06 MOTION TO ADJOURN THE MTG.
- DECEMBER 28, 2006
- 308-06 MOTION TO AUTHORIZE THE FISCAL OFFICER TO TRANSFER WITHIN FUNDS.
- 309-06 MOTION TO APPROVE 2007 TEMPORARY APPROPRIATIONS.
- 310-06 MOTION TO ACCEPT. POL. INVENTORY.

DECEMBER 28, 2006

311-06 MOTION TO ADJOURN THE MTG.

11

11

11

**BAZETTA TOWNSHIP ORGANIZATIONAL MEETING
HELD JANUARY 04, 2006**

Present: Mike Piros, Bill Glancy and Jeff Bates.

Fiscal Officer, Martha Urchek, opened the meeting by asking for a motion to appoint the new Chairman of the Board for 2006.

01-06 Motion by Mr. Piros, seconded by Mr. Bates to appoint Bill Glancy as the Chairman of the Board for 2006.

Vote on Mr. Glancy for Chairman: Mr. Bates YES, Mr. Glancy YES and Mr. Piros YES.

YES 3

NAY 0

Mr. Glancy elected Chairman for 2006.

Fiscal Officer, Martha Urchek, asked for a motion to appoint the new Vice Chairman of the Board for 2006.

02-06 Motion by Mr. Glancy, seconded by Mr. Bates to appoint Mike Piros as the Vice Chairman of the Board for 2006.

Vote on Mr. Piros for Vice Chairman: Mr. Bates YES, Mr. Glancy YES and Mr. Piros YES.

YES 3

NAY 0

Mr. Piros elected Vice Chairman for 2006.

At the time the meeting was turned over to the new Chairman, Bill Glancy.

03-06 Motion by Mr. Glancy, seconded by Mr. Piros to set the dates and times for the 2006 regular meetings, with a work session one hour before each meeting, for the first Monday at 9 AM and the third Monday at 7 PM otherwise designated by a holiday.

Vote on Motion: Mr. Bates YES, Mr. Glancy YES and Mr. Piros YES.

YES 3

NAY 0

Motion Carried.

JANUARY 04, 2006

04-06 Motion by Mr. Piros, seconded by Mr. Bates to employ Department Heads as listed below:

Road Superintendent Parke (\$2,009.27 bi-weekly)
 Police Chief Sayers (\$1,973.22 bi-weekly)
 Fire Chief McKenzie (\$1,950.57 bi-weekly)

Vote on Motion: Mr. Bates YES, Mr. Glancy YES and Mr. Piros YES.

YES 3

NAY 0

Motion Carried.

05-06 Motion by Mr. Bates, seconded by Mr. Piros to employ township employees listed below at their current rates:

Zoning Inspector, Jerry Mauger (\$1,075/month)
 Cemetery Sexton, Lorin Hopkins (\$250/month)
 Part-time Secretary/Zoning Secretary, Stephanie Hovis (\$8/hour)
 Unlock/Lock Doors, Lynn Smith (\$7/hour)
 Administrative Secretary, Robyn Metheny (\$15.80/hour)
 Asst. Road Superintendent, Kris Parke (\$17.59/hour)
 Mechanic, Jim Goodhart (\$17.80/hour)
 Equipment Operator, Marcus Tempesta (\$15.37/hour)
 Entry Level Equipment Operator, Mike Arnal (\$14.44/hour)
 Sergeant, Tom Miller (\$21.81/hour)
 Sergeant, Nick Papalas (\$21.81/hour)
 Patrolman: Chris Herlinger (\$19.21/hour), Mike Hovis (\$19.46/hour), Joe Sofchek (\$18.91/hour)
 Part-time Police Secretaries: Kim Parthemer and Kara Stan (\$8/hour)
 Part-time Police Officers: Leroy Long, Jason Manes, Ivey Maybou, Brian Porterfield and Shawn Rentz (\$9/hour)
 Captain: Dennis Lewis (\$16.73/hour) and Tom Rink (\$16.48/hour)
 Lieutenant, Brian Taylor (\$14.95/hour)
 Firefighter-Paramedic: Elliott Fike (\$13.34/hour), Ray Gallatin (\$12.84/hour), Lionel Lesh (\$13.34/hour), Mike Mannella (\$13.14/hour), Mike Smith (\$13.24/hour), David Walter (\$13.14/hour), Gary Walters (\$12.84/hour) and Mike White (\$12.84/hour)
 Part-time Firefighter/Paramedic: Brian Pugh (\$9.25/hour), Michael Rodriques (\$9.25/hour), William Claypoole (\$9.25/hour), William Lembaugh (\$9.25/hour) and Robert Wasser (\$9.25/hour)
 Part-time Firefighter/EMT: Kerry Rhodes (\$8.75/hour), Gary Search (\$8.75/hour), Chris Votino (\$8.75/hour), Robert Baron (\$8.75/hour), Stephan Craiger (\$8.75/hour),

JANUARY 04, 2006

Robert Kern (\$8.75/hour) and Medic Stephen Anderson (\$9.25/hour)

Vote on Motion: Mr. Bates YES, Mr. Glancy YES and Mr. Piros YES.

YES 3

NAY 0

Motion Carried.

06-06 Motion by Mr. Piros, seconded by Mr. Bates to set the zoning hours for Monday from 6-9 PM and on Thursday 9 AM – 1 PM or otherwise designated by a holiday.

Vote on Motion: Mr. Bates YES, Mr. Glancy YES and Mr. Piros YES.

YES 3

NAY 0

Motion Carried.

07-06 Motion by Mr. Piros, seconded by Mr. Bates to continue with Attorney Mark Finamore as Legal Counsel.

Vote on Motion: Mr. Bates YES, Mr. Glancy YES and Mr. Piros YES.

YES 3

NAY 0

Motion Carried.

08-06 Motion by Mr. Piros, seconded by Mr. Bates to approve purchase orders for uniform allowance, fuel, maintenance contracts and EMS billing and supplies.

Vote on Motion: Mr. Bates YES, Mr. Glancy YES and Mr. Piros YES.

YES 3

NAY 0

Motion Carried.

09-06 Motion by Mr. Bates, seconded by Mr. Piros to approve blanket certificates for usual expenditures. After much discussion on the amount of the blanket certificates and number of signatures with one being the department head. This will be discussed further at a later date.

Vote on Motion: Mr. Bates, YES, Mr. Glancy YES and Mr. Piros YES.

YES 3

NAY 0

Motion Carried.

JANUARY 04, 2006

Mr. Glancy explained to the audience that according to the Ohio Township's Association the new title for the Clerk was changed on December 15, 2005 to Fiscal Officer.

10-06 Motion by Mr. Piros, seconded by Mr. Bates to authorize the Fiscal Officer to invest excess money in Money Market Accounts, Star Ohio and Savings whenever excess money is available.

Vote on Motion: Mr. Bates YES, Mr. Glancy YES and Mr. Piros YES.

YES 3

NAY 0

Motion Carried.

11-06 Motion by Mr. Bates, seconded by Mr. Piros to accept donations of equipment or any donations when received.

Vote on Motion: Mr. Bates YES, Mr. Glancy YES and Mr. Piros YES.

YES 3

NAY 0

Motion Carried.

12-06 Motion by Mr. Piros, seconded by Mr. Bates to authorize the payment of costs for Trustees and Fiscal Officer's attendance at the monthly Trumbull Township Association meetings.

Vote on Motion: Mr. Bates YES, Mr. Glancy YES and Mr. Piros YES.

YES 3

NAY 0

Motion Carried.

13-06 Motion by Mr. Bates, seconded by Mr. Piros to authorize membership into the Ohio Township Association and attendance at the annual state association conferences including payment of expenses for the Trustees and Fiscal Officer.

Vote on Motion: Mr. Bates YES, Mr. Glancy YES and Mr. Piros YES.

YES 3

NAY 0

Motion Carried.

Mr. Glancy interjected that due to budget restraints, the Fiscal Officer will be the only one attending the Winter Conference in February in Columbus.

REGULAR MEETING – JANUARY 04, 2006

At this time Mr. Glancy asked if there was any public participation.

Mr. Rick Snowberger, 4722 Durst Clagg Road, has a concern about a letter he received from the township legal counsel, Mark Finamore, pertaining to cleaning of the roadside ditch at his property. He asked for the Road Superintendent and the Trustees to come out and visually inspect the ditch and find out where the problem is. The Trustees and Mr. Parke will meet at the property owner's residence at 2 PM on Friday, January 06th. Mr. Piros stated it is necessary for the township to make the road safe. Mr. Snowberger asked for prices if he has to replace the tile. Mr. Parke read two price quotes; Pipelines – 12" plastic pipe at \$4.39/ft. and Carter Lumber – 12" plastic pipe at \$4.49/ft.

Rex Pealer, 3430 Warren-Meadville Road, asked if anything could be done at the intersection of Warren-Meadville Road and McCleary Jacoby Road due to a recent accident there on December 19th. Mr. Piros said there are two options, a guard rail on old Route 5 or have a traffic study done. Mr. Glancy asked Mr. Piros if he would write a letter to the Trumbull County Engineer's Office for a traffic study. Mr. Piros agreed he would write the letter for the board.

14-06 Motion by Mr. Bates, seconded by Mr. Piros to approve the minutes of the December 19th meeting.

Vote on Motion: Mr. Bates YES, Mr. Glancy YES and Mr. Piros YES.

YES 3

NAY 0

Motion Carried.

The following correspondence was read by Fiscal Officer, Martha Urchek:

1. Reminder of the January 10th meeting at 9 AM at the Planning Office on Hamad Estates Plat 1.
2. Reminder of the Zoning Commission Quarterly Meeting tonight at 7 PM to discuss revisions and additions to the zoning book.
3. Received Training Session for BWC. Jeff Bates will attend one of the sessions in keeping with our 10 Step Plan.
4. Sent email to Marly at the Tribune changing meeting date from January 03rd to today due to a schedule conflict.

JANUARY 04, 2006

5. Letter from Attorney Finamore on requirements for availability of contract for professional design services to move the administrative office to the police station. A resolution needs to be passed.
6. Letter from Attorney Finamore to Mr. & Mrs. Rick Snowberger on cleaning of roadside ditches.
7. Letter from Attorney Finamore to Mr. Rose Mackey on intersection of Cadwallader-Sonk Road and McCleary Jacoby Road view obstruction.
8. Meeting notice from District 6 Public Works on Tuesday, January 10th at 9 AM in Austintown pertaining to the pre-application schedule for Bazetta Township for Durst Clagg Road Improvement Project and the Howland Wilson Road Improvement Project for 2006. Meeting for our township is 9:40 AM.
9. New contract available for co-operative purchasing.

15-06 Motion by Mr. Bates, seconded by Mr. Piros to approve the payment of bills.
Vote on Motion: Mr. Bates YES, Mr. Glancy YES and Mr. Piros YES

YES 3
NAY 0
Motion Carried.

16-06 Motion by Mr. Piros, seconded by Mr. Bates to approve purchase orders.
Vote on Motion: Mr. Bates YES, Mr. Glancy YES and Mr. Piros YES.

YES 3
NAY 0
Motion Carried.

Police Chief Sayers:

Chief Sayers had to leave but turned in his December Monthly Report along with his Annual Report.

Mr. Glancy mentioned there would be a work session with the police department on Sunday, January 15th at noon at the police station. Mr. Glancy asked Martha to advertise this work session.

JANUARY 04, 2006

Fire Chief McKenzie:

Chief McKenzie has nothing to report except the two staff members, who were involved in the December 20th accident, returned to work today, January 04th.

He mentioned he has been working with the insurance company on the accident and the ambulance is fully covered for replacement. He has sent the heart monitor out as well as the cot and chair. The laptop was ruined. Everything should be fully covered.

Assistant Road Superintendent Parke:

Sitting in for Road Superintendent Frank Parke was Kris Parke. He asked the Trustees to consider changing burial hours not to be earlier than 10 AM. They had a recent burial at 9 AM and weren't quite finished when the funeral procession was pulling into the cemetery. Mr. Piros asked how often this has happened and Mr. Parke said just once that he knows of. Mr. Piros continued by saying that we won't do anything about this until it becomes an issue.

Mr. Bates asked Mr. Parke if he had been given the schedule from his father about listing of roads to clean out the ditches before we have a flooding problem in the spring. Mr. Parke said he knew nothing of the schedule, but will mention it to his father in the morning. Mr. Bates said we want to be pro-active and not wait until we have a problem.

Mr. Bill Olson, 4736 Durst Clagg Road, asked if they will use a rotary machine to clean out ditches and Mr. Parke replied yes.

At this time, Mr. Olson submitted pictures of Mr. Snowberger's ditch and the flooding.

Zoning Inspector Mauger:

Mr. Mauger said he received a letter from Attorney Finamore that the title search was finished for 4160 North Park and there are two liens on the property. Mr. Finamore will write letters to the two mortgage companies.

Mr. Mauger said the ground breaking date for the Super Wal-Mart has been set back to sometime in June.

Chief McKenzie mentioned to Mr. Mauger that someone is living in the house at the corner of Everett Hull and North Park.

JANAURY 04, 2006

Park Board:

No one was present.

Safety Committee:

Chief McKenzie has nothing to report, but the next meeting will be in March.

Administration:

17-06 Motion by Mr. Bates, seconded by Mr. Piros to change the next regular meeting night to Tuesday, January 17th at 7 PM due to the holiday..

Vote on Motion: Mr. Bates YES, Mr. Glancy YES and Mr. Piros YES.

YES 3

NAY 0

Motion Carried.

No one was present for the Eagle Scout project for Aaron Hanson.

Mr. Glancy said that the Trustees have considered moving the administrative offices to the police station for quite some time as a financial endeavor. Are there any questions from the audience on this? This move will not be done overnight, as many things need to be considered. No public participation at this time.

Mr. Glancy said in regard to the meeting on January 10th at 9 AM at the Planning Office on the Hamad Estates Plat 1, it will not be necessary at this time for anyone from the township office to attend.

Mr. Glancy reminded the Trustees and Mr. Mauger of the Zoning Commission Quarterly Meeting tonight at 7 PM to discuss revisions and additions to the present zoning book.

After much discussion on a streetlight at the intersection of Warren-Meadville and Johnson Plank Road Extension the following action was taken.

18-06 Motion by Mr. Bates, seconded by Mr. Piros to go ahead to install a light pole for \$1,072.47 at our cost with an annual cost of operation of \$44.16.

Vote on Motion: Mr. Bates YES, Mr. Glancy YES and Mr. Piros YES.

JANUARY 04, 2006

YES 3

NAY 0

Motion Carried.

Mr. Glancy asked Martha to send an authorization letter to Ohio Edison to proceed with this installation.

Mr. Glancy at this time appointed the following to be department liaisons: Mr. Glancy will represent the police department, Mr. Piros will represent the fire department and Mr. Bates will represent the road department. Mr. Glancy said it is good for the departments as well as the Trustees to rotate the liaisons every year.

Mr. Pealer asked Mr. Glancy what is the story on the township getting water. Mr. Glancy said it is not the township stopping progress, but the county sanitary engineer as well as the county commissioners. We have not given up.

Mr. Piros on another note said he received a phone call from Dr. Enyeart on the Lakeshore Allotment septic problems.

He will call the county commissioners to set up a meeting with this board and our legal counsel plus a resident from the Lakeshore Allotment. More on this as it progresses.

19-06 Motion by Mr. Piros, seconded by Mr. Bates to go into executive session at 10:25 AM to discuss negotiations with no action being taken.

Vote on Motion: Mr. Bates YES, Mr. Glancy YES and Mr. Piros YES.

YES 3

NAY 0

Motion Carried.

The Trustees returned to regular session at 11:45 AM with no action taken.

20-06 Motion by Mr. Piros, seconded by Mr. Glancy to adjourn the meeting.

Vote on Motion: Mr. Bates YES, Mr. Glancy YES and Mr. Piros YES.

YES 3

NAY 0

Motion Carried.

ATTEST:

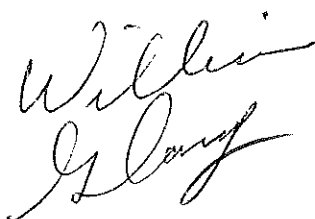

BAZETTA TOWNSHIP REGULAR MEETING MINUTES
JANUARY 17, 2006
7:00 PM

Present: Trustees Bill Glancy, Mike Piros and Jeff Bates, Legal Counsel Mark Finamore

Old Business:

Mr. Piros talked about the existing problems on Durst Clagg Road where he, Mr. Glancy and Mr. Parke went to the resident's property on January 06th. This will be covered in the road report tonight.

The Trustees were reminded of the 8:00 Am Work Session here at the township hall tomorrow, January 18th and also of the 9:30 meeting tomorrow with the Commissioners on the sewer projects for the township at the Commissioners Meeting Room.

The typing of the zoning book was discussed. It will have to be done from scratch as the person who originally typed the book is now deceased. It was decided among the Trustees that the Zoning Secretary, Stephanie Hovis, would retype the book at a cost of \$8 per hour.

Mr. Piros said after approval of the new zoning book, it would have to be registered and recorded with the Trumbull County Recorder's Office at a cost of \$100.

Mr. Piros has set the deadline of Friday, February 10th for all information on the Spring Flyer.

Mr. Bates mentioned about the road department cleaning out ditches on McCleary Jacoby Road with the rotary ditcher and asked that they do not use that again as it made a mess. After much discussion, Mr. Parke will call the county to do a ditch survey.

At this time, Mr. Parke requested a work session with the Trustees to go look at ditches and the date and time was set for Monday, January 23rd at 8:00 AM here at the township hall to meet first and then go and look at ditches.

Mr. Bates questioned the four hours call out time. Mr. Parke said if they get the work done, they go home. Mr. Bates would like the crew to stay the four hours. Mr. Finamore said the Trustees have the right to say they are to stay the four hours as they are being paid four hours.

Mr. Glancy said this would be added to the work session on Monday, January 23rd.

Mr. Bud Bowen, State Route 5, said the road department has a rough job, doesn't think we are treating them fairly.

JANUARY 17, 2006

Mr. Glancy asked Martha to advertise the Road Work Session.

21-06 Motion by Mr. Piros, seconded by Mr. Bates to approve the minutes from the January 04th meeting.

Vote on Motion: Mr. Bates YES, Mr. Glancy YES and Mr. Piros YES.

YES 3

NAY 0

Motion Carried.

The following correspondence was read:

1. Letter from Trumbull County Recorder on filing zoning resolutions and amendments in the Recorder's Office.
2. A letter from Eastgate Regional Council of Governments for a nomination on the Eastgate Transportation Enhancement Selection Committee.

Public Participation:

Aaron Hanson of Sterling Drive presented sketches to the Trustees of his Eagle Scout project to replace two signs and place a new sign at the Bazetta Cemetery on Johnson Plank Road along with a bench to be placed between some pine trees at the cemetery. The total cost of the three signs would be around \$400. Mr. Finamore at this time asked Aaron how much money would be involved for the new bench. His reply was around \$40 at which time Mr. Finamore volunteered to donate the money for the bench.

Mr. Glancy complimented Aaron on a nice job and asked when the project is finished to let him know so we would contact the newspaper.

22-06 Motion by Mr. Bates, seconded by Mr. Piros to donate up to \$450 for project of Aaron Hanson.

Vote on Motion: Mr. Bates YES, Mr. Glancy YES and Mr. Piros YES.

YES 3

NAY 0

Motion Carried.

Aaron will bring to the office a letter for us to sign for him to give to his Scout Master that he will be working on this particular project.

JANUARY 17, 2006

23-06 Motion by Mr. Piros, seconded by Mr. Bates to approve the purchase orders.

Vote on Motion: Mr. Bates YES, Mr. Glancy YES and Mr. Piros YES.

YES 3

NAY 0

Motion Carried.

24-06 Motion by Mr. Bates, seconded by Mr. Piros to pay the bills.

Vote on Motion: Mr. Bates YES, Mr. Glancy YES and Mr. Piros YES.

YES 3

NAY 0

Motion Carried.

Fire Chief McKenzie:

Chief McKenzie had nothing to report.

Mr. Bates asked Chief McKenzie why we have pagers and cell phones for the firemen. Chief McKenzie said the cell phones cannot be used in the hospitals, but pagers can.

Mr. Finamore at this time stated the two firemen, Kevin Lesh and Brian Taylor, did an excellent job with their preparedness and professionalism at the disposition last week regarding an accident.

Road Superintendent Parke:

Mr. Parke asked the Trustees to reconsider the statement of values for vehicles and buildings. Mr. Glancy suggested that Martha contact our OTARMA representative to set up a meeting with the Trustees and the department heads to revamp our statement of values.

In lieu of the meeting with the Trustees and the Durst Clagg resident on January 06th pertaining to the ditch, Mr. Parke said he flushed and opened the ditch. He also contacted Duke's and the cheapest for a piece of equipment with a camera is \$200 per hour port to port.

Mr. Piros said to contact Trumbull County to flush first, if there is a blockage, mark it and dig it up.

Mr. Bud Bowen, State Route 5, asked why flush again? Mr. Parke explained there could be some restriction and needs to be flushed again. It could be a broken tile or a misaligned tile.

JANUARY 17, 2006

Mr. Parke further reported his department has straightened up all the signs and have worked on patching holes.

Mr. Piros asked about the written report that was requested at the last meeting. Mr. Parke will have this report at the next meeting, February 06th. Mr. Piros asked to have hours with a breakdown of what they did during these hours similar to the Police Monthly Report.

Mr. Bill Olson, Durst Clagg Road, said he would prefer to have the backhoe rather than the rotary ditcher.

Mr. Rick Snowberger, Durst Clagg Road, said there are old trees in the ditch towards the gas well road and asked if these could be cleaned out.

Mr. Olson said this is the McFalls and Clemans property, which is south of them.

Police Chief Sayers:

Chief Sayers reported that the January 15th Work Session with the officers and the Trustees was very productive and requested quarterly work sessions with the police department. Mr. Glancy said this was a good idea. At the work session, the Robinson case was discussed along with mutual aid to surrounding townships.

Chief Sayers asked the Trustees to adopt the "Resolution to Provide Police Protection to Other Public Entity."

25-06 Motion by Mr. Piros, seconded by Mr. Bates to adopt the "Resolution to Provide Police Protection to other Public Entity."

Vote on Motion: Mr. Bates YES, Mr. Glancy YES and Mr. Piros YES.

YES 3

NAY 0

Motion Carried.

Chief Sayers asked the Trustees to approve the revised Trumbull County Mutual Aid Agreement effective January 18, 2006.

26-06 Motion by Mr. Bates, seconded by Mr. Piros to approve the revised Trumbull County Mutual Aid Agreement effective January 18, 2006.

Vote on Motion: Mr. Bates YES, Mr. Glancy YES and Mr. Piros YES.

JANUARY 17, 2006

YES 3

NAY 0

Motion Carried.

Chief Sayers presented the heating and cooling renewal from Best Furnace for all five buildings at the following breakdown of costs for one year for a total cost of \$1,107.00:

Police Building	\$372.00
Fire Station #13	219.00
Administration Building	128.00
Fire Station #11	260.00
Road Garage	128.00

27-06 Motion by Mr. Piros, seconded by Mr. Bates accept the renewal from Best Furnace for all five buildings at the total cost of \$1,107.

Vote on Motion: Mr. Bates YES, Mr. Glancy YES and Mr. Piros YES.

YES 3

NAY 0

Motion Carried.

Chief Sayers reported on the recent drug arrest on Elm Road where a vehicle was forfeited to the police department.

Zoning Inspector Mauger:

Mr. Mauger had nothing to report, but is working with Mr. Finamore on problem dwellings.

Mr. Finamore explained to Mr. Glancy about tax credits for people who buy dilapidated houses for a tax credit.

Mr. Kevin Murphy, 2085 Timber Way Drive, spoke on getting his zoning permit in August of 2005 to build a 12 x 12 shed. Now the Conservation Club is saying it is on their property. In January of 2006 Mr. Murphy received a letter from Attorney Grove and showed it to Mr. Finamore who advised him to contact Mr. Grove to provide a survey showing that the shed is on the Conservation Club's property. If it is true, then the shed will have to be moved. Mr. Murphy replied that will be a task as it is built between trees. Former owner had tree houses and nothing was ever said. Mr. Mauger said if his property line is where he said it should be, the shed is 10' on his property and is in compliance with our regulations.

JANUARY 17, 2006

Mr. Olson, Durst Clagg Road, asked about fences if they have to be set back 10' from the property line. Mr. Mauger said there is a new fencing regulation and fences have to be set back 2' off the property line.

Park Board:

No one was present.

Safety Committee:

There was nothing to report.

Administration:

Mr. Piros stated we are permitted by law to have two alternate zoning commission members and asked Martha to place an ad in the newspaper for two alternates.

28-06 Motion by Mr. Piros, seconded by Mr. Bates to proceed with the Fire Renewal Levy for .08 Mill for the purpose of providing and maintaining fire equipment and facilities, water supplies, fire alarm telegraphs, ambulance equipment, emergency medical services and the payment of firemen or fire fighting companies employed by a fire department for fire fighting company for a five year period.

Vote on Motion: Mr. Bates YES, Mr. Glancy YES and Mr. Piros YES.

YES 3

NAY 0

Motion Carried.

29-06 Motion by Mr. Bates, seconded by Mr. Piros to proceed with the Police Renewal Levy for .06 Mill for the purpose of providing and maintaining motor Vehicles and equipment used directly by the police department, to pay salaries and benefits of permanent police personnel, or costs of contracts to obtain police protection or to provide ambulance for emergency medical services operated by the police department for a five (5) year period.

Vote on Motion: Mr. Bates YES, Mr. Glancy YES and Mr. Piros YES.

YES 3

NAY 0

Motion Carried.

JANUARY 17, 2006

30-06 Motion by Mr. Bates, seconded by Mr. Piros to proceed with the Police Renewal Levy for 1.8 Mill for the purpose of providing and maintaining motor Vehicles and equipment used directly by the police department, to pay salaries and benefits of permanent police personnel, or costs of contracts to obtain police protection or to provide ambulance for emergency medical services operated by the police department for a five (5) year period.

Vote on Motion: Mr. Bates YES, Mr. Glancy YES and Mr. Piros YES.

YES 3

NAY 0

Motion Carried.

Mr. Glancy asked Martha to proceed with these three (3) levies through the prosecutor's office. Mr. Glancy also asked the community for their support of all three (3) levies to be placed on the May 2nd ballot.

The Park Board Meeting was scheduled for Monday, January 30th at 8 PM to go over the 2006 budget.

Evaluations for at-will employees need to be returned to the Administration Office before Friday, January 27th.

31-06 Motion by Mr. Piros, seconded by Mr. Bates to accept the IRS current rate of mileage effective January 1, 2006 to be 44.5.

Vote on Motion: Mr. Bates YES, Mr. Glancy YES and Mr. Piros YES.

YES 3

NAY 0

Motion Carried.

32-06 Motion by Mr. Piros, seconded by Mr. Bates to nominate Champion Trustee, Tom Tracy, as our representative for the 9-1-1 Technical Advisory Board due to his past experience.

Vote on Motion: Mr. Bates YES, Mr. Glancy YES and Mr. Piros YES.

YES 3

NAY 0

Motion Carried.

JANUARY 17, 2006

33-06 Motion by Mr. Piros, seconded by Mr. Glancy to accept the hourly rate increase for legal counsel, Mark Finamore, from \$90 to \$100 an hour.

Vote on Motion: Mr. Bates YES, Mr. Glancy YES and Mr. Piros YES.

YES 3

NAY 0

Motion Carried.

Mr. Glancy explained to the public that in December of 2005 the title of "Clerk" was changed to "Fiscal Officer".

34-06 Motion by Mr. Piros, seconded by Mr. Bates to authorize the Fiscal Officer to transfer within police funds \$4,500.00 from 09-A-04C Tools and Equipment, to 09-A-05C, Supplies.

Vote on Motion: Mr. Bates YES, Mr. Glancy YES and Mr. Piros YES.

YES 3

NAY 0

Motion Carried.

35-06 Motion by Mr. Piros, seconded by Mr. Glancy to authorize the Fiscal Officer to issue a purchase order to Ainsley Oil for \$10,200.00 for three (3) months for gasoline and diesel usage for departments.

Vote on Motion: Mr. Bates YES, Mr. Glancy YES and Mr. Piros YES.

YES 3

NAY 0

Motion Carried.

Mr. Bates asked Mr. Piros if the Regional Chamber was still looking at bulk purchasing of gasoline. Mr. Piros said they are still in the talking stages, but the prices they were quoted are a year old now.

Discussion on zoning change for the Administration Building, 3372 State Route #5 was tabled.

Mr. Glancy set the "free" garage sale to be the last week-end in April with the clean-up day to be Saturday, May 6th from 8 AM to 4 PM.

Mr. Piros asked Mr. Parke to send out for bids for the clean up day collection.

JANUARY 17, 2006

36-06 Motion by Mr. Piros, seconded by Mr. Bates to adjourn the meeting.
Vote on Motion: Mr. Bates YES, Mr. Glancy YES and Mr. Piros YES.

YES 3

NAY 0

Motion Carried.

ATTEST

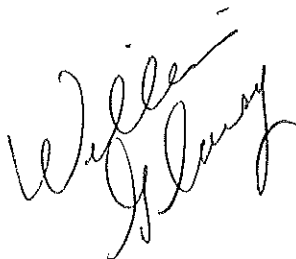
A handwritten signature in cursive script, appearing to read "William J. Glancy". The signature is written in dark ink and is positioned to the right of the "ATTEST" text.

11/11/2023 10:11:11 AM

11

11

11

BAZETTA TOWNSHIP REGULAR MEETING MINUTES
FEBRUARY 06, 2006
9:00 AM

Present: Trustees Bill Glancy, Mike Piros and Jeff Bates.

Old Business:

Mr. Piros received a letter from Dr. Enyeart of the Trumbull County Health Department on two issues, the first one being the posting of signs in contaminated areas in the Lakeshore Allotment area. Mr. Piros told Dr. Enyeart that according to our legal counsel's advice that the township assumes no responsibility to post the signs, but he the Health Department could. The second issue had to do with the timeline of the sanitary sewers for the Lakeshore Allotment area and would like to meet with the Trustees after Dr. Enyeart has a meeting with the Sanitary Engineer.

Mr. Glancy attended the water meeting at Southington and attended a meeting along with Mr. Piros with the Trumbull County Commissioners who had a conference call with the Sanitary Engineer and Dr. Enyeart on the sanitary sewers for the Lakeshore Allotment area.

Chief McKenzie asked the Trustees if this sanitary sewer problem was county wide and the response was yes.

Bill Olson, Durst Clagg Road, gave the Trustees his report and said he would go with Mr. Parke's decision to do whatever is necessary on Durst Clagg to put in a tee or a catch basin.

37-06 Motion by Mr. Glancy, seconded by Mr. Piros to approve the minutes, after correction is made, of the January 17th meeting.

Vote on Motion: Mr. Bates YES, Mr. Glancy YES and Mr. Piros YES.

YES 3

NAY 0

Motion Carried.

Correspondence was read by Fiscal Officer Martha Urchek.

1. Martha reported she attended the Winter Conference in Columbus and received six hours of certification.
2. She mentioned the picture of Mr. Parke with our new backhoe, which appeared in the Tribune.
3. She also mentioned the picture of Mr. Piros who collected money for the Muscular Dystrophy.

FEBRUARY 06, 2006

4. The Trumbull County Health Department meeting agenda for January 25th at 7:00 pm at the Hubbard Administration Building.
5. Trumbull County Health Department concerning the complaint on 4160 North Park. Could not inspect the house as they couldn't gain entrance. A copy was given to Mr. Mauger, Zoning Inspector.
6. Eastgate District 6 Public Works Integrating Committee Meeting on January 26th to evaluate the county for local Transportation Improvement Program projects.
7. Received a letter from Attorney Finamore on his letter to a resident on Cadwallader-Sonk Road concerning the intersection view obstruction.
8. Received a letter from Trumbull County Engineer, John Latell, on the construction estimate for maintenance and performance bonds on Hamad Estates Plat No. 1
9. Reminder from Trumbull County Storm and Water meeting on January 26th. Mr. Mauger is to attend.
10. Reminder of annual meeting of the Trumbull County District Advisory Council on March 07th for election of officers.
11. Received a letter from Attorney Finamore on the proposed Constitution for County Township Association for certification of the association's constitution and by laws to be presented for vote at the next township association's meeting in March.
12. Articles were sent to the newspaper on the work sessions and advertisement for new Zoning Committee alternate member.

38-06 Motion by Mr. Bates, seconded by Mr. Piros to approve the purchase orders.

Vote on Motion: Mr. Bates YES, Mr. Glancy YES and Mr. Piros YES.

YES 3

NAY 0

Motion Carried.

39-06 Motion by Piros, seconded by Mr. Bates to approve the payment of bills.

Vote on Motion: Mr. Bates YES, Mr. Glancy YES and Mr. Piros.

FEBRUARY 06, 2006

YES 3

NAY 0

Motion Carried.

Road Superintendent Parke:

Mr. Piros asked Mr. Parke for a more detailed report. Mr. Parke gave the quote from Alexander's Pest Control for three mosquito spraying at \$1,210 per service. The dates are May 22nd, June 26th and July 31st.

40-06 Motion by Mr. Bates, seconded by Mr. Glancy for two mosquito sprayings, May 22nd and June 26th at a total cost of \$2,420.

YES 3

NAY 0

Motion Carried.

Mr. Glancy asked Martha to advertise the dates in the local newspapers.

Mr. Parke continued by saying his department removed a tree on Howland Wilson Road as a safety issue. He is looking into a double stop sign on Howland Wilson Road and Cadwallader Sonk Road.

Mr. Parke was asked to get bids for the May clean up day on May 06th and to call the County Engineer's office to pick up a TV that was dropped off at Sweet Pete's on Bazetta Road.

Mr. Glancy asked Mr. Parke about the sweeping and striping of the roads. Mr. Parke will contact the County Engineer's office.

Mr. Mauger said he attended a Soil and Water meeting and they are to set up a meeting with the road superintendent on the sweeping of the roads.

Police Chief Sayers:

Chief Sayers gave the Trustees his monthly report. He said his department gave out 10 citations on the east side and 12 on the west side due to speeding.

Chief Sayers also mentioned in the last two weekends, there was criminal damage on the west side (mailboxes, breaking into vehicles).

FEBRUARY 06, 2006

Chief Sayers asked the Trustees to approve a service agreement for his mobile data terminals in the amount of \$1,800 for the year to be taken out of 09-A-10 account.

41-06 Motion by Mr. Bates, seconded by Mr. Glancy to approve the service agreement for the police department mobile data terminals in the amount of \$1,800 for the year and to be taken out of the 09-A-10 account.

Vote on Motion: Mr. Bates YES, Mr. Glancy YES and Mr. Piros YES.

YES 3

NAY 0

Motion Carried.

At this time Mr. Piros interjected that the department heads are to watch their budgets very carefully and to live within their budgets as the general fund will no longer fund the departments.

Due to Mr. Bates needing to leave for work, the following motion was made:

42-06 Motion by Mr. Glancy, seconded by Mr. Piros to give a 1% raise effective with the February 17th pay date for the pay period of 01/29/06 through 02/11/06 to Police Chief Sayers, Fire Chief McKenzie, Zoning Inspector Mauger and Administrative Secretary Robyn Metheny.

Vote on Motion: Mr. Bates YES, Mr. Glancy YES and Mr. Piros YES.

YES 3

NAY 0

Motion Carried.

Mr. Bates left the meeting at 9:45 AM.

Fire Chief McKenzie:

Chief McKenzie reported that two firefighters, Dennis Lewis and Ray Gallatin, will receive awards from the Shriners on Tuesday night, February 07th. Chief McKenzie will take pictures and will have this in the Spring Flyer.

Chief McKenzie asked the Trustees for approval to purchase 10 tires for two squads from Hovis Tire at a total cost of \$891.68 to come out of account 10-A-10, Repair Account.

43-06 Motion by Mr. Piros, seconded by Mr. Glancy to approve the purchase of 10 tires for two squads from Hovis Tire at a total cost of \$891.68 to come out of account 10-A-10, Repair Account.

Vote on Motion: Mr. Bates YES, Mr. Glancy YES and Mr. Piros YES.

FEBRUARY 06, 2006YES 3NAY 0

Motion Carried.

Chief McKenzie also asked the Trustees to purchase a new laptop computer for Squad EMS reports from Dell in the amount of approximately \$1,000 to be paid out of account 14-A-07, EMS Grant.

44-06 Motion by Mr. Piros, seconded by Mr. Glancy to purchase a laptop computer for Squad EMS reports from Dell in the amount of up to \$1,000 and is to be paid out of account 14-A-07, EMS Grant.

Vote on Motion: Mr. Bates YES, Mr. Glancy YES and Mr. Piros YES.

YES 3NAY 0

Motion Carried.

Zoning Inspector Mauger:

Mr. Mauger gave the Trustees his monthly report and reported that he is still working with Legal Counsel with abandoned houses. He wrote a letter to the health department to remove 4160 North Park Avenue off their list as someone is living there now.

Mr. Glancy asked Mr. Mauger about the septic tank for the trailers on Bazetta Road, the Medzie property. Mr. Mauger will look into this matter.

Park Board:

No one was present.

Safety Committee:

Chief Sayers reported the next Safety Committee meeting will be Tuesday, March 07th at 9 AM at the police station.

Mr. Olson questioned Mr. Parke about the swimming pool line on the Snowberger's property as it drains on his property. Mr. Parke said he cannot go on their property.

Administration:

The next Trustee meeting will be Tuesday, February 21st at 7 PM due to the holiday.

FEBRAURY 06, 2006

The free garage sale dates will be Thursday, April 27th through Sunday, April 30th. Mr. Glancy said no permits will be necessary.

Clean up day will be May 06th from 8 AM – 4 PM.

45-06 Motion by Mr. Piros to stay with the same prices as last year.

Vote on Motion: Mr. Bates YES, Mr. Glancy YES and Mr. Piros YES.

Car Load	\$ 3.00
Single Axle Trailer	\$ 6.00
Pick Up Truck	\$10.00
Multi Axle Trailer	\$15.00
One Ton Truck	\$25.00
Larger Trucks	\$50.00

YES 3

NAY 0

Motion Carried.

Mr. Glancy reminded the department heads to look at their vehicles serial numbers on the Statement of Values with OTARMA.

Request for a zone change from R-1 to C-1 on the administration building will be sent to the Zoning Commission Board.

All flyer information is due to Mr. Piros by February 11th.

46-06 Motion by Mr. Piros, seconded by Mr. Glancy to proceed with the second reading for the Police Renewal levy for .06M to be placed on May 02nd ballot for the purpose of providing and maintaining motor vehicles and equipment used directly by the police department, to pay salaries and benefits of permanent police personnel, or costs of contracts to obtain police protection or to provide ambulance services operated by a police department for a five year period.

Vote on Motion: Mr. Bates YES, Mr. Glancy YES and Mr. Piros YES.

YES 3

NAY 0

Motion Carried.

FEBRUARY 06, 2006

47-06 Motion by Mr. Piros, seconded by Mr. Glancy to proceed with the second reading for the Police Renewal levy for 1.8M to be placed on the May 02nd ballot for the purpose of providing and maintaining motor vehicles and equipment used directly by the police department, to pay salaries and benefits of permanent police personnel or cost of contracts to obtain police protection or to provide ambulance for emergency medical services operated by the police department for a five year period.

Vote on Motion: Mr. Bates YES, Mr. Glancy YES and Mr. Piros YES.

YES 3

NAY 0

Motion Carried.

48-06 Motion by Mr. Piros, seconded by Mr. Glancy to proceed with the second reading for the Fire Renewal levy for 0.8 M to be placed on the May 02nd ballot for the purpose of providing and maintaining fire equipment and facilities, water supplies, fire alarm telegraphs, ambulance equipment, emergency medical services and the payment of firemen or fire fighting companies employed by a fire department for fire fighting company for a five year period.

Vote on Motion: Mr. Bates YES, Mr. Glancy YES and Mr. Piros YES.

YES 3

NAY 0

Motion Carried.

49-06 Motion by Mr. Piros, seconded by Mr. Glancy to authorize the Fiscal Officer to transfer within funds \$66,937 from 01-A-27 General (Transfers) to 01-A-06 General (Insurance) to pay insurance liability on vehicles and buildings to OTARMA.

Vote on Motion: Mr. Bates YES, Mr. Glancy YES and Mr. Piros YES.

YES 3

NAY 0

Motion Carried.

50-06 Motion by Mr. Piros, seconded by Mr. Glancy to authorize the Fiscal Officer to transfer within funds \$372 from 09-A-14 Police (Other Expenses) to 09-A-10 Police (Contracts) to pay contract with Best Furnace.

Vote on Motion: Mr. Bates YES, Mr. Glancy YES and Mr. Piros YES.

YES 3

NAY 0

Motion Carried.

FEBRUARY 06, 2006

There was a discussion on the 2006 Budget. Mr. Piros explained we had a loss of revenue from 2005.

51-06 Motion by Mr. Piros, seconded by Mr. Glancy to accept the amount of rates as determined by the Budget Commission and authorizing the necessary tax levies and certifying them to the County Auditor.

Vote on Motion: Mr. Bates YES, Mr. Glancy YES and Mr. Piros YES.

YES 3

NAY 0

Motion Carried.

There was a discussion on the zoning commission alternate member resumes. We received two resumes which will be forwarded to the Zoning Commission Board.

OTARMA representative, Earl Gray, stated he could either be here on Thursday, February 09th or Friday, February 10th at 9:00 AM. A decision was made to meet with Mr. Gray at the administration office with the Trustees and department heads on Friday morning at 9:00 AM.

52-06 Motion by Mr. Piros, seconded by Mr. Glancy to accept the Park Board 2006 Budget of \$17,000.

Vote on Motion: Mr. Bates YES, Mr. Glancy YES and Mr. Piros YES.

YES 3

NAY 0

Motion Carried.

Mr. Piros stated he had confirmation from our Legal Counsel that we can charge fees at the park. Mr. Parke said we can't because of ODNR. Mr. Glancy said the Valley Extreme held a three-day event at the park last year and either charged or asked for donations. This will be tabled until the next meeting when our Legal Counsel will be present.

At this time Mr. Frank Fuda, a candidate for Trumbull County Commissioner was introduced by Mr. Piros who talked about his accomplishments and asked for our support in the upcoming election. He said he would help all the townships with their water and sanitary sewer projects.

FEBRUARY 06, 2006

53-06 Motion by Mr. Piros, seconded by Mr. Bates to adjourn the meeting.

Vote on Motion: Mr. Bates YES, Mr. Glancy YES and Mr. Piros YES.

YES 3

NAY 0

Motion Carried.

A handwritten signature in cursive script, appearing to read "Wallace Glancy". The signature is written in dark ink and is positioned to the right of the text "Motion Carried."

ATTEST

[illegible]

[illegible]

[illegible]

[illegible]

BAZETTA TOWNSHIP REGULAR MEETING MINUTES
FEBRUARY 21, 2006
7:00 PM

Present: Trustees Bill Glancy, Mike Piros and Jeff Bates, Legal Counsel Mark Finamore

Old Business:

Mr. Bates attended a BWC Safety Council meeting on February 16th and the topic was "The Benefit of Funding Your Safety Program" by Steve Cochran, Comp Management Inc.

Mr. Piros submitted a rough drawing of the proposed move of the administrative office to the police station. He asked the board to approve a facility study cost analysis of the site and not to exceed \$25,000.00.

54-06 Motion by Mr. Glancy, seconded by Mr. Bates to solicit a proposal from Jakubick and Associates for a feasibility study on the site and not to exceed \$25,000.00.

Vote on Motion: Mr. Bates YES, Mr. Glancy YES and Mr. Piros YES.

YES 3

NAY 0

Motion Carried.

Mr. Glancy reported that despite all hearsay, Super Wal-Mart will be breaking ground in 2006 and should open in June of 2007.

Public Participation:

Mr. Paul Rezabek, 2773 Cadwallader-Sonk Road, brought to the attention of the Trustees a car accident in which his daughter was involved in on Howland Wilson Road at 7:45 AM on January 25th. His concern was that the salt trucks had not been out yet. He also noted that another car had gone into a ditch on the same street. He wanted to know the policy to get the roads salted or plowed. Mr. Parke said the on-duty police officer will call the road department. Mr. Parke said it didn't start snowing until 5:30 AM that day. Mr. Parke stated it takes the road crew about 45 minutes to get the trucks ready. We have three trucks, one goes to the west side of the township, one goes to the Timber Creek area and one goes east and in this case Cadwallader-Sonk and Howland Wilson Roads. Chief Sayers said ice started around 5:00 AM per his on-duty police officer. Mr. Razebek realized we can't have 24 on-call for snow and ice control, as it would not be cost effective. Chief Sayers said he will re-emphasize this matter with his department.

Pam Schaffer, who owns the Harley Davidson Store on Elm Road, questioned an access road to the traffic light for the new Super Wal-Mart. If this doesn't happen, it will create an unsafe condition for the traffic coming from her store as well as the car wash. She has contacted Randy

FEBRUARY 21, 2006

Law, Marc Dann, ODOT, and the engineer for Wal-Mart. Mr. Parke suggested she stay after the meeting and he will show her the map.

55-06 Motion by Mr. Piros, seconded by Mr. Bates to approve the minutes of the February 06th meeting.

Vote on Motion: Mr. Bates YES, Mr. Glancy YES and Mr. Piros YES.

YES 3

NAY 0

Motion Carried.

Correspondence was read by Fiscal Officer Martha Urchek.

1. Signed up to win four stop signs at the Winter Conference and Signs & Blanks notified that I did not win.
2. Letter from Trumbull County Engineer's Office in response to our letter on the intersection of Warren-Meadville Road and McCleary Jacoby Road. They relocated the stop sign to improve motorists' view of traffic plus installed an additional stop sign and stop ahead sign to reduce the chance that motorist would not be aware they are required to stop.
3. Trumbull County Board of Health meeting for Wednesday, February 15th at the Hubbard Administration Building.
4. Trumbull County Board of Health regular meeting minutes of January 25th.
5. Letter from Dr. Enyeart of the Trumbull County Health Department pertaining to a band-aid fix for sanitary sewers for the Lakeshore Allotment.
6. Letter from Terminal Supply Company stating their representative retired and they are in the process of hiring someone.
7. Letter on "Introduction of Trumbull County Blueprint to End Homelessness" luncheon on February 28th at DiLucia's. A representative is needed to attend.
8. Received invitation to attend Tom Letson's kick-off campaign breakfast on Saturday, February 18th at the Mocha House. He is running for the 64th Ohio House District.
9. Article sent to the Tribune for cemetery clean up.

FEBRUARY 21, 2006

10. Annexation of 1.0292 acre parcel to the City of Cortland. The hearing is on April 12th at 11:00 AM in the Commissioner's Office.
11. Emergency Operations Center will hold a meeting on February 21st at noon to discuss a full scale exercise at the Regional Airport on April 14th that will impact the surrounding areas.
12. BWC statement for a credit of \$18,039.71. Our experience rate was reduced from 0.101007 to 0.084008 for the period 7/1/04 through 12/31/04.

56-06 Motion by Mr. Piros, seconded by Mr. Bates to approve the purchase orders.

Vote on Motion: Mr. Bates YES, Mr. Glancy YES and Mr. Piros YES.

YES 3

NAY 0

Motion Carried.

57-06 Motion by Bates, seconded by Mr. Piros to approve the payment of bills.

Vote on Motion: Mr. Bates YES, Mr. Glancy YES and Mr. Piros YES.

YES 3

NAY 0

Motion Carried.

Police Chief Sayers:

Chief Sayers reported 10 citations issued on Bazetta Road for speeding. He also reported citations on Niles-Cortland Road. Chief Sayers informed the audience if they have any concerns about speeding or anything to call him.

Bud Bowen, State Route 5, complained about the light at Rick's Auto Service that blinds you going north on State Route 5. Chief Sayers will stop and talk with Rick.

Fire Chief McKenzie:

Chief McKenzie said he had Mr. Glancy sign the papers for the wrecked ambulance to be taken to a salvage place in Youngstown. The ambulance left on Tuesday, February 21st. Chief McKenzie has a committee formed to look at perspective bidders for a new ambulance. The replacement cost for the ambulance was \$78,240 and a new one will cost around \$77,240.

FEBRUARY 21, 2006

Chief McKenzie also reported that the fire truck with the damaged doors left on February 17th for Dean's Trucking in Twinsburg.

Chief McKenzie attended the Trumbull County EMA Advisory Board Meeting on February 15th where he volunteered to be the Damage Resource Assessment Officer, which entails reporting of damages in the township to FEMA.

Chief McKenzie, Chief Sayers and Mr. Piros attended a meeting of the Trumbull County Local Emergency Planning Committee (LEP). The Youngstown Air Base and LEP in conjunction with the EMA will conduct an emergency training scenario at the Air Base on April 14th. Chief Sayers explained to the audience that this is a response plan for preparedness in case of an emergency in the county.

Road Superintendent Parke:

Mr. Parke reported that his department is patching roads.

Zoning Inspector Mauger:

Mr. Mauger asked the Trustees to make a motion to declare 3054 North Park property to be a nuisance and demolish it as it is unfit for human habitat.

58-06 Motion by Mr. Bates, seconded by Mr. Piros to hire someone and they are to follow all the county regulations.

Vote on Motion: Mr. Bates YES, Mr. Glancy YES and Mr. Piros YES.

YES 3

NAY 0

Motion Carried.

Mr. Mauger will attend a Zoning Inspector meeting in Lordstown on Wednesday, February 22nd.

Park Board:

No one was present.

Safety Committee:

There will be a meeting on March 7th at 9:00 AM at the police station and the topic of "Backing Up" will be discussed.

FEBRUARY 21, 2006

Mr. Glancy asked the department heads the outcome of the meeting with the OTARMA representative on February 10th and Mr. Parke replied we are waiting on this report. Mr. Earl Gray said it would take about 3-4 weeks.

Administration:

Mr. Glancy announced that the second meeting in April, which is April 17th, would be changed from 7:00 PM to 9:00 AM due to a schedule change.

The public was reminded of the township cemetery clean up before March 01st.

The Zoning Commission will conduct a public hearing on March 01st at 7:00 PM to hear the request for a zone change for the property at 3372 State Route 5, the township administration building. The request is to change from residential to commercial.

Discussion on park fees was tabled at this time.

59-06 Motion by Mr. Piros, seconded by Mr. Glancy to retain township records indefinitely at this time.

Vote on Motion: Mr. Bates YES, Mr. Glancy YES and Mr. Piros YES.

YES 3

NAY 0

Motion Carried.

Discussion on appointing person(s) who can copy and give out public records was tabled at this time.

60-06 Motion by Mr. Piros, seconded by Mr. Bates to authorize the Fiscal Officer to transfer within the following funds:

09-A-14 Police (other expenses) to 09-A-10 Police (contracts) \$7,050.06 for three months for 9-1-1.

09-A-04C Police (tools & equipment) to 09-A-05C Police (supplies) \$4,500.00 for three months for Ainsley Oil.

Vote on Motion: Mr. Bates YES, Mr. Glancy YES and Mr. Piros YES.

YES 3

NAY 0

Motion Carried.

FEBRUARY 21, 2006

61-06 Motion by Mr. Piros, seconded by Mr. Glancy to amend resolution 310-05 to read "Township shall pay the OPERS Pick Up contribution for elected township officials in the same percentage amount that is currently being paid by the township for all other township employees in the form and manner and to the extent permitted by law and the rules and regulations of the State Auditor's Office and the Ohio Public Employees Retirement System effective January 01, 2006."

Vote on Motion: Mr. Bates YES, Mr. Glancy YES and Mr. Piros YES.

YES 3

NAY 0

Motion Carried.

Mr. Piros asked Mr. Parke that since we needed to remove the drinking fountain, to repair the wall with a piece of plywood and paint it.

62-06 Motion by Mr. Bates, seconded by Mr. Piros to authorize the Fiscal Officer to make a purchase order out for the 9-1-1 Center in the amount of \$5,703.16 for January and February, 2006.

Vote on Motion: Mr. Bates YES, Mr. Glancy YES and Mr. Piros YES.

YES 3

NAY 0

Motion Carried.

63-06 Motion by Mr. Piros, seconded by Mr. Bates to authorize the Fiscal Officer to purchase a new drum for the administrative office Toshiba copier in the amount of \$357.90.

Vote on Motion: Mr. Bates YES, Mr. Glancy YES and Mr. Piros YES.

YES 3

NAY 0

Motion Carried.

Mr. Piros gave Mark Finamore a copy of a letter he received from Dr. Enyeart of the Trumbull County Health Department asking for a legal response. This is in regard to the band-aid fix policy for the Lakeshore Allotment area.

Mr. Piros reported on the spring flyer. He received a quote from Howland Printing for 2,800 flyers. The cost for black and white was \$579 and the cost for color was \$1,320.

FEBRUARY 21, 2006

64-06 Motion by Mr. Glancy, seconded by Mr. Bates to accept the quote for 2,800 black and white flyers for a cost of \$579.00.

Vote on Motion: Mr. Bates YES, Mr. Glancy YES and Mr. Piros YES.

YES 3

NAY 0

Motion Carried.

There was a discussion on the next level of cemetery mapping with Burrows Consulting Services. At the present time we have the software for data only. The next level would be the mapping of the graves for a cost of \$6,480, which the cost would be shared by the City of Cortland. This was tabled as the present time.

Mr. Piros received a quote from Ohio Edison for the Timber Creek Heights Lighting District; \$11,473.64 for installation with the cost of \$213.48 to light them. Ohio Edison does not install the poles. Therefore, we need to go out for quotes. This was tabled at this time.

At this time Chief Sayers asked the Trustees for a work session with the police department for Monday, March 27th at 7:30 PM.

Bill Olson, Durst Clagg Road, asked about the regulations of the gas well drilling on Warren-Meadville Road. Mr. Glancy said we, as the township can't do anything about it.

65-06 Motion by Mr. Bates, seconded by Mr. Piros to adjourn the meeting at 8:35 PM.

Vote on Motion: Mr. Bates YES, Mr. Glancy YES and Mr. Piros YES.

YES 3

NAY 0

Motion Carried.

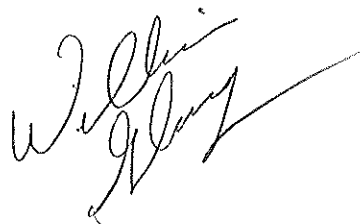

ATTEST

11/11/2020 11:11:11 AM

1

2

3

BAZETTA TOWNSHIP REGULAR MEETING MINUTES
MARCH 06, 2006
9:00 AM

Present: Trustees Bill Glancy, Mike Piros and Jeff Bates.

Old Business:

Mr. Bates reported that he will attend a BWC seminar in the next few months.

Mr. Piros along with Mr. Glancy will attend the Democratic Precinct Committeemen Meeting on Tuesday, March 07th and will support the Trumbull County Commissioner candidate who will support our township with water and sewer projects. Due to a conflict of schedules, they won't be able to attend the Board of Health meeting to elect a new member, which is the same day and time.

Mr. Glancy said we only had one candidate, Frank Fuda, attend our meeting.

Mr. Tracey Gould of Bazetta Road asked the Trustees who votes on the Board of Health membership. Mr. Glancy replied that all the townships have a vote.

Mr. Gould asked the Trustees for their support to have a meeting with the Board of Health on the new septic system that was put in at his neighbors' front yard. It is an eye sore and he won't be able to sell his house. Mr. Glancy agreed it is an eye sore and he will call and make an appointment with the Board of Health for a meeting with Mr. Gould and himself on this matter.

66-06 Motion by Mr. Piros, seconded by Mr. Bates to approve the minutes of the February 21st meeting.

Vote on Motion: Mr. Bates YES, Mr. Glancy YES and Mr. Piros YES.

YES 3

NAY 0

Motion Carried.

Mr. Gould asked Mr. Mauger about the building code permits. Mr. Mauger said the resident or contractor comes into the township office first and then goes to the county.

67-06 Motion by Mr. Piros, seconded by Mr. Bates to approve the purchase orders.

Vote on Motion: Mr. Bates YES, Mr. Glancy YES and Mr. Piros YES.

YES 3

NAY 0

Motion Carried.

MARCH 06, 2006

68-06 Motion by Bates, seconded by Mr. Piros to approve the payment of bills.

Vote on Motion: Mr. Bates YES, Mr. Glancy YES and Mr. Piros YES.

YES 3

NAY 0

Motion Carried.

The following correspondence was read by Fiscal Officer, Martha Urchek:

1. Letter from Community & Economic Development Corporation regarding multifamily residential development near the Pauni Apartments on Route 46 in Cortland since we are within a one half mile radius of this development.
2. Township Fiscal Report for 2005 is complete and an ad was placed in the newspaper for the public to review if they so wish.
3. Copy of letter Ray Ratell sent to the Board of Elections on his Longview Golf Course being voted wet.
4. Letter from Mark Finamore on the legal opinion on renting or leasing township property or facilities.
5. Trumbull County Board of Health Meeting Agenda for Wednesday, March 01st at the health department office.
6. Letter from the Lakeview Heat Baseball appreciating the township to let them use the park baseball fields and will submit a new schedule for 2006.

Fire Chief McKenzie:

Chief McKenzie had nothing for the board except a letter to be signed by the Trustees and notarized by Martha on the Proof of Loss for the damaged fire truck for \$7,558.50 less the \$250 deductible.

Road Superintendent Parke:

Mr. Parke gave his monthly report to the Trustees. Mr. Piros complimented Frank on his monthly report.

MARCH 06, 2006

Also questioned was the roadside shrine at Cadwallader-Sonk and Henn Hyde Roads. There are numerous ribbons and flowers on the tree due to a recent fatality there. Mr. Piros asked if it was in the road right-of-way and Mr. Parke replied no. Then leave it alone.

Mr. Parke asked if Kris needed to attend the meeting on March 22nd with Kimley Horn, Inc. and the reply was yes as it involves a subcontractor of Wal-Mart for a gas station. Mr. Glancy said Kris will be paid overtime for this 3:00 PM meeting at the township hall.

Mr. Parke mentioned he can't get into the cemetery to work because the ground is still frozen, but is patching holes on the roadways. He should get to the cemetery by the end of the week.

Mr. Glancy at this time opened the only bid received for the Spring Clean Up Day on Saturday, May 06th from 8 AM to 4 PM. The bid was from Sunburst who will provide 25-yard packer trucks for trash removal at a cost of \$585 per load plus will provide ample number of Sunburst employees to help residents to unload their vehicles. At no charge to the township, Sunburst will provide 40-yard roll-off dumpsters for hot water tanks, washers, dryers, etc.

69-06 Motion by Mr. Bates, seconded by Mr. Glancy to accept the bid from Sunburst of \$585 per load for a total cost of \$1,755.00. This is to be taken out of the general fund 01-A-26.
Vote on Motion: Mr. Bates YES, Mr. Glancy YES and Mr. Piros YES.

YES 3

NAY 0

Motion Carried.

John Morris, Durst Clagg Road, questioned the Trustees on a flyer he received at his home over the weekend involving the road department negotiations. Mr. Glancy said there are two sides to every story and half of the flyer is untrue. They get full hospitalization whereas the police and fire pay part of their hospitalization due to a cap limit in their contract. They are paid a good salary which was supported by other townships our size. As far as the legal counsel is concerned, the prosecutor's office only issues answers on the law not on negotiations. Many issues not agreed upon and the raises have not been on the table yet, therefore a fact finder has been called in.

Mr. Piros commented that each side has to give and take a little. They came in at the top and we can in at the bottom. Somewhere these two teams have to meet in the middle.

Mr. Bates at this time asked Mr. Parke to elect one part-time employee to come back this year to take care of the park starting on March 27th for 20 hours a week working from 9:00 AM to 1:00 PM. He is to let the Trustees know before March 17th who will be coming back. The part-time employee will be paid out of the general fund and will answer to the Board of Trustees.

MARCH 06, 2006

The park opens on April 01st.

A letter is being drafted and will be mailed to the other two part-time employees that due to an Amended Certificate of Resources, this year's budget was lower of about \$331,000.00 from 2005's Amended Certificate of Resources.

Due to one of the Trustees needing to leave for work, the agenda was changed as follows:

70-06 Motion by Mr. Bates, seconded by Mr. Glancy to approve a donation of \$300 for the Easter Egg Hunt to Lisa Voytek. The Easter Egg Hunt will be at the township park from 9:00 AM to 1:00 PM on Saturday, April 08th.

Vote on Motion: Mr. Bates YES, Mr. Glancy YES and Mr. Piros YES.

YES 3

NAY 0

Motion Carried.

71-06 Motion by Mr. Glancy, seconded by Mr. Bates to approve Postal Mail Sort to mail out the spring flyers to all registered voters by the end of March in the amount of \$541.01.

Vote on Motion: Mr. Bates YES, Mr. Glancy YES and Mr. Piros YES.

YES 3

NAY 0

Motion Carried.

Mr. Piros asked Mr. Parke if there was electricity to the gazebo and the reply was no. He asked Mr. Parke to get estimates from a licensed electrician and to report back at the next meeting. He also asked him to check with the park board first to see if they have done anything about electricity to the gazebo.

72-06 Motion by Mr. Bates, seconded by Mr. Glancy to authorize the Fiscal Officer to transfer the following monies within funds:

05-A-12A Cemetery (Insurance) to 05-A-13 Cemetery (Unemployment Compensation) in the amount of \$1,800.

10-C-06 Fire (EMS Repairs) to 10-A-07 Fire (Utilities) in the amount of \$3,500.

Vote on Motion: Mr. Bates YES, Mr. Glancy YES and Mr. Piros YES.

YES 3

NAY 0

Motion Carried.

MARCH 06, 2006

Police Chief Sayers:

Chief Sayers gave the Trustees his monthly report and had nothing for the board.

Zoning Inspector Mauger:

Mr. Mauger gave the Trustees his monthly report.

Again Mr. Gould asked if someone would go with him to the Board of Health on the septic tank that was put in at his neighbor's house and Mr. Glancy said he will call and set up a meeting and will accompany Mr. Gould to this meeting.

Trustee Bates left the meeting at 9:35 AM.

Park Board:

There was no one present.

Safety Committee:

Chief Sayers reported that the Safety Committee Meeting will be at the police station on Tuesday, March 07th at 9:00 AM.

Mr. Gould asked about the mosquito spraying and asked them about the water that lies year round in this ditch. He asked who to call and Mr. Parke told him to contact the county engineer's office. Mr. Gould said it doesn't do any good to spray for mosquitoes the way his ditch is. Mr. Piros reminded everyone that May 22nd and June 26th is the scheduled mosquito spraying dates for the township.

Bill Olson mentioned an off road right-of-way and John Klimet of Niles Cortland Road asked about sewers and asked about the huts on his street to be torn down.

Mr. Glancy said Neal Eaton owns the property where the huts (old Scotty Trailer Sales) are and his plans were to develop behind them, but no plans have been forwarded to the township.

Mr. Glancy restated that he and Mr. Piros would endorse the right Trumbull County Commissioner candidate who will work with the townships for sewer and water and to bring businesses into the area and who will work with communities.

Mr. Mauger mentioned that Cass Lake just got water from the City of Cortland, but the trailer park owner is paying for this.

MARCH 06, 2006

Mr. Glancy said he has been trying to work with the City of Cortland on water for a long time. It was asked where Cortland City gets their water and it is from seven huge wells. Cortland won't work with Bazetta on a dual project for water.

73-06 Motion by Mr. Piros, seconded by Mr. Glancy to adjourn the meeting.
Vote on Motion: Mr. Glancy YES and Mr. Piros YES.

YES 2

NAY 0

Motion Carried.

ATTEST

A handwritten signature in cursive script, appearing to read "William Glancy", is written over the "ATTEST" text.

**WORK SESSION WITH PARK BOARD AND TRUSTEES
MARCH 15, 20056 AT 8:00 PM
HELD AT THE TOWNSHIP ADMINISTRATION BUILDING**

Present: Bill Glancy, Mike Piros, Jeff Bates, Martha Urchek, Mark Finamore, Eleanor Governor and Beth Barnes.

Discussion on:

- Park Budget
 - Park Rules
 - Park Maintenance
 - Park up-grade
1. Electric for gazebo
 2. Landscaping
 3. Fees for park usage

No action taken.

BAZETTA TOWNSHIP REGULAR MEETING MINUTES
MARCH 20, 2006
7:00 PM

Present: Trustees Bill Glancy, Mike Piros, Jeff Bates and Mark Finamore, Legal Counsel.

Old Business:

Mr. Piros spoke on the gas brokerage firm that was discussed at length at the Ohio Township Association Meeting. This brokerage firm was hired by Howland Township. There are certain requirements and special pricing for townships.

Also discussed was updating our Township's Administrative Policy in the future. Mr. Piros is picking up the township's spring flyer from Howland Printing and will take them to Postal Mail Sort and hopefully by the end of this week, the residents will receive their flyers in the mail.

Mr. Bates had nothing to report.

Mr. Glancy made a notation about his telephone conversation with Frank Migliozi of the Health Department regarding the 5' septic tank installation on Bazetta Road to resident, Tracey Gould, that the township has no legal recourse. Mr. Gould stated he wanted to have a meeting with Mr. Migliozi not a telephone conversation. Mr. Gould said the owner saved \$1,200 by installing the septic tank that way and we, the neighbors, lost \$25,000 value off our property value.

Mr. Finamore said the best way to get this resolved would be for Mr. Gould and his neighbors to attend a Board of Health meeting. Mr. Glancy said he would draft a letter to Mr. Migliozi requesting a meeting with Mr. Gould and his neighbors on this problem.

Public Participation:

Joe Billecki, 2456 Northview Drive, presented the Trustees with pictures of an abandoned home with garbage all over the yard at 2458 Northview Drive. Trustee Glancy asked Mr. Mauger to do an inspection and bring findings back to the board. Then the board would send a letter to the homeowner. Mr. Glancy mentioned that this won't be done overnight as we have to follow the proper procedures.

Don Sutliff, 2348 State Route 305, asked about the progress of the sewer projects for the township. Mr. Piros answered that through Issue II, a grant of \$300,000 was received for the feasibility study. He talked with Mr. Newbrough, Sanitation Engineer, about 3-4 weeks ago and possibly sometime in April, a meeting with the residents on the cost will be held and then it is up to the residents. If the residents say yes, we follow the process for bids, accept the bid and then hire a contractor. Bazetta Township doesn't meet the qualifications for more grant money.

MARCH 20, 2006

Mr. Finamore said Issue II, now Issue I, is a capital fund improvement pool amount of money.

Mr. Sutliff asked about water and Mr. Glancy said it is not the township holding this up, it is the commissioners. They don't want private water companies coming into the county.

Mr. Finamore commented on the county and the MVSD. They do not want private water companies because after the private water companies place all the piping, they can at anytime increase the price of water to the residents and the residents do not have any say so. In Trumbull County alone, there are 17 different water rates. Mr. Finamore assured the residents that their Trustees are working very hard on the sewer and water projects.

Mr. Piros said some developers have fronted the money for water and sewer but re-coup their money when they sell the property.

Resident Robyn Hineman, 2408 Northview Drive, stated her displeasures with one of the Trustees for comments made about her husband and Delphi and also wanted to know how the road negotiations were progressing. She also stated she felt the Trustees should pay for their health care.

Mr. Finamore stated it was perfectly legal for the Trustees to take the insurance coverage offered by the township.

Mr. Glancy answered her concerns about the negotiations with the road department. Although progress has been made, the contract negotiations are continuing with a meeting on April 03rd.

Several residents questioned the fliers they received from the Teamsters stating that talks were stalled.

Mr. Piros said after the next round of negotiations a fact finder's hearing will be held. There are a lot of issues on the table and hopes to get these resolved before the fact-finding phase.

Mr. Glancy said their contract expired in May of 2004 and the reason it has taken this long is because the road department chose to be represented by the Teamsters. He said the township union had to be decertified when they went with the Teamsters Union and a whole new contract had to be written from scratch.

Rosie Stockton, 2658 McCleary Jacoby Road, asked what the lowest salary was for the full-time worker and Kris Parke answered it was \$14.44. Mr. Glancy said they have 100% paid insurance benefits plus holiday, vacation, sick and personal time.

MARCH 20, 2006

John Lubianetzki, 2762 Tall Oaks Drive, asked why we are paying \$125 an hour for an attorney. Mr. Finamore answered that there is a pool of about nine legal firms who specialize in contract negotiations and Bazetta is using one of them, Clemans, Nelson & Associates.

John Morris, Durst Clagg Road, asked why the township didn't use the prosecutor's office as it is free. He has talked with Mr. Earnheart and he told him yes they represent Bazetta and they can use the prosecutor's office. Mr. Morris asked to have Jim Saker call him, but has not heard from Mr. Saker as of today. Mr. Finamore said the prosecutor's office is available to the townships on legal matters, but refrains from collective bargaining problems.

Joe Billecki, Northview Drive, asked about the brick wall at Saddlebrook. Kris Parke said after review, it is okay as it is off our road right-of-way. Condos have a new set of rules as they are private roads.

Ken Flask, State Route 5, asked if anything is going to be done about the visibility problem at McCleary Jacoby Road and Cadwallader-Sonk Road. Mr. Piros said a letter dated December 27, 2005 from Mr. Finamore was sent to the owner, Rose Mackey, 2210 Cadwallader-Sonk Road asking her to trim back the branches in question to alleviate the obstruction and to provide a clear view of all traffic to avoid a potential accident.

74-06 Motion by Mr. Piros, seconded by Mr. Glancy to approve the minutes of the March 06th meeting.

Vote on Motion: Mr. Bates YES, Mr. Glancy YES and Mr. Piros YES.

YES 3

NAY 0

Motion Carried.

The following correspondence was read:

1. Clean Up Day information was received from Sunburst for DFWP, insurance liability and BWC certificate.
2. Newspaper ads placed in the Tribune for bid on demolition on 3054 North Park Avenue, requesting qualification for professional design services for new addition to the Police Station to move the administration offices there, and bids for installation of 13 electric street lights for Timber Creek Heights.
3. Received a letter from Attorney Mark Finamore in answer to Trumbull County Health Board letter to the township on 02/01/06 regarding Lakeshore Allotment sewer problem.

MARCH 20, 2006

4. Received a letter from resident Rosemary Herhold on the recent flyer she received in her paper box from the Teamsters on the road negotiations.
5. Meeting agenda from the Trumbull County Board of Health--Wednesday, March 15th at the Warren Administration Building at 7:00 PM.
6. Regular meeting minutes from Trumbull County Board of Health for 02/15/06.
7. Email from Darlene St. George, Howland Administrator, on legislative updates and another Email from Darlene St. George on House Bill 299 on urban revitalization.
8. Letter from Ohio EPA on public comments on permit modification for Thomas Steel Strip Corporation in Warren for a wastewater discharge permit. Comments at the Ohio EPA will be received until March 23, 2006.
9. Letter from State Representative Randy Law on the Mosquito Lake Lodge for a presentation to the Trumbull County Visitor's Bureau in April.
10. News release to Mr. Piros from Dominion East Ohio announcing Dominion's wholly owned subsidiary, Consolidated Natural Gas has reached an agreement to sell two natural gas utilities for \$969.6 million.
11. Letter from Trustees to our state representatives, Sandra Harwood, Randy Law, Marc Dann and Timothy Grendell opposing State Bill 191, Mandatory zoning language that requires mining operations be a permitted or conditional use in all zoning districts in a township including in residential areas, overrides current township zoning laws enacted by the townships across Ohio.
12. Invitation to the Trustees from the Trumbull County Engineer's Office for the Annual Township meeting at DiVieste's on April 06th. Reservations due by March 31st.
13. Copy distributed to all township concerned from Fowler Trustee Al Crabbs on the spreadsheets for all township cemeteries fees as well as zoning and town hall fees.
14. Received 2006 Environmental Collections event from Geauga-Trumbull Solid Waste Management District. This was distributed to all department heads to post.
15. Minutes from March 11th Safety Committee. The next meeting will be June 06th at 9:00 AM at the police station.

MARH 20, 2006

16. Trumbull County Commissioners to amend the Journal action taken by the Commissioners on January 31, 2006 to accept and approve the petition of Hamad Estates Plat No. 1.
17. Letter from Attorney Mark Finamore on the Willard Smith versus Hentosh Builders, Jerre Hentosh, Charles Sayers and Jerry Mauger.
18. Copy of Grassroots Clippings – Monthly newsletter of the Ohio Township Association. This was given to all Trustees.

Mr. Piros made a comment on the letter the Trustees sent to our state representatives objecting House Bill 191 regarding the mining operations. He said this will take away our authority.

Mr. Piros also commented on the letter the Trustees sent to ODOT about our displeasures on the traffic light for the new Super Wal-Mart at Millennium Boulevard. The Harley Davidson Store as well as the Four Seasons Car Wash does not have access to Millennium Boulevard. Their access is from State Route 5 and have requested an access to Millennium Boulevard to avoid extreme traffic hazards.

75-06 Motion by Mr. Bates, seconded by Mr. Piros to approve the purchase orders.
Vote on Motion: Mr. Bates YES, Mr. Glancy YES and Mr. Piros YES.

YES 3
NAY 0
Motion Carried.

76-06 Motion by Piros, seconded by Mr. Glancy to approve the payment of bills.
Vote on Motion: Mr. Bates YES, Mr. Glancy YES and Mr. Piros YES.

YES 3
NAY 0
Motion Carried.

Road Superintendent Parke:

Due to Frank Parke being on vacation, Kris Parke stated the cemeteries are cleaned up and residents can now put their Easter decorations up.

Police Chief Sayers:

Chief Sayers had nothing to report.

MARCH 20, 2006

Fire Chief McKenzie:

Chief McKenzie reported that Lt. Brian Taylor as part of his college course created a community satisfaction survey that was sent in January, 2006 to all residents and non residents for their reply on how they viewed our services at the time of their need. These results will be used to improve our services. Lt. Taylor received an excellent grade on this report.

Zoning Inspector Mauger:

Mr. Mauger reminded the Trustees and Kris Parke of the 3:00 PM meeting on March 22nd at the administration building with Kimley Horn who represents Murphy Oil. Murphy Oil is the contract gas station that Super Wal-Mart is putting in on Millennium Boulevard. Per the Trustees request, Mr. Mauger will call John Woolard, Storm Water Coordinator of the Trumbull Soil and Water Conservation District to attend this meeting.

Safety Committee:

Chief Sayers has nothing to report.

Administration:

Mr. Glancy reminded everyone of the following dates:

May 06th from 8:00 AM – 4:00 PM is Clean up Day.

April 01st the township park will open.

April 08th from 9:00 AM until 12:00 noon is the Easter Egg Hunt at the Township Park.

April 27th through April 30th is the Free Township Garage Sale.

The Fiscal Officer presented the Final Appropriations for calendar year 2006 for all funds for the township.

The Fiscal Officer read the full Permanent Appropriation Resolution:

BE IT RESOLVED by the Board of Trustees of Bazetta Township, Trumbull County, Ohio, that to provide the current expenses and other expenses of said Board of Trustees, during the fiscal year, ending December 31, 2006, the following sums be and the same are hereby set aside and appropriated for the several purposes for which expenditures are to be made for and during said fiscal year, as follows, viz: (attachments included).

MARCH 20, 2006

77-06 Motion by Mr. Bates, seconded by Mr. Glancy to adopt the aforementioned Permanent Appropriation Resolution.

Vote on Motion: Mr. Bates YES, Mr. Glancy YES and Mr. Piros YES.

YES 3

NAY 0

Motion Carried.

78-06 Motion by Mr. Piros, seconded by Mr. Glancy to authorize the Fiscal Officer to transfer monies within funds from 01-A-26 Administration (other expenses) to 01-E-01 Street Lighting in the amount of \$1,072.47 (Street light for corner of Warren-Meadville Road and Johnson Plank Extension) and to transfer monies within funds from 01-A-06 Administration (insurance) to 01-A-27 Administration (transfers) in the amount of \$66,937.00 (charge back from departments for OTARMA).

Vote on Motion: Mr. Bates YES, Mr. Glancy YES and Mr. Piros YES.

YES 3

NAY 0

Motion Carried.

79-06 Motion by Mr. Piros, seconded by Mr. Bates to approve the invoice from Trumbull Soil and Water Conservation District for our 2006 conservation appropriation in the amount of \$2,416.00.

Vote on Motion: Mr. Bates YES, Mr. Glancy YES and Mr. Piros YES.

YES 3

NAY 0

Motion Carried.

80-06 Motion by Mr. Glancy, seconded by Mr. Piros to appoint Mark Franko, 2959 Fallehn Drive (330-637-0936) and Todd McCart, 3458 Bazetta Road (330-360-8924) as alternate board members for the Zoning Commission Board effective immediately.

Vote on Motion: Mr. Bates YES, Mr. Glancy YES and Mr. Piros YES.

YES 3

NAY 0

Motion Carried.

MARCH 20, 2006

81-06 Motion by Mr. Piros, seconded by Mr. Glancy to adjourn the meeting.

Vote on Motion: Mr. Bates YES, Mr. Glancy YES and Mr. Piros YES.

YES 3

NAY 0

Motion Carried.

ATTEST

A handwritten signature in black ink, appearing to read "William Glancy". The signature is written in a cursive style with a long, sweeping underline that extends to the right.

GENERAL: 01-A		
01-A-01	SALARIES-TRUSTEES	\$ 35,000.00
01-A-02	SALARY-FISCAL OFFICER	\$ 20,000.00
01-A-03	TRAVEL & OTHER EXPENSES	\$ 5,000.00
01-A-04	SUPPLIES - ADMINISTRATION	\$ 7,500.00
01-A-05	EQUIPMENT - ADMINISTRATION	\$ 3,500.00
01-A-06	INSURANCE	\$ 60,000.00
01-A-10	LEGAL COUNSEL	\$ 35,000.00
01-A-12	EMPLOYER'S RETIREMENT CONTRIBUTION	\$ 35,000.00
01-A-15	WORKMEN'S COMPENSATION	\$ 6,123.97
01-A-15A	UNEMPLOYMENT COMPENSATION	\$ -
01-A-16	GENERAL HEALTH DISTRICT	\$ 20,000.00
01-A-17	AUDITOR'S & TREASURER'S FEE	\$ 5,000.00
01-A-18	ADVERTISING DELINQUENT LANDS	\$ 500.00
01-A-19	STATE EXAMINERS' CHARGE	\$ -
01-A-21	ELECTION EXPENSES	\$ 5,000.00
01-A-22	CONDEMNED PROPERTY	\$ -
01-A-25	CONTINGENCY ACCOUNT	\$ -
01-A-26	OTHER EXPENSES	\$ 50,000.00
01-A-27	TRANSFERS	\$ 47,487.42
01-A-28	SECRETARY/CLERICAL STAFF SALARY	\$ 60,000.00
01-A-29	CONTRACTS	\$ 20,000.00
01-A-90	FICA/MEDICARE - EMPLOYER'S SHARE	\$ 2,500.00

TOTAL - 01-A	\$ 417,611.39
---------------------	----------------------

GENERAL: 01-B - TOWN HALL, MEMORIAL BUILDINGS & GROUNDS		
01-B-01	SALARIES	\$ 6,000.00
01-B-02	IMPROVEMENT OF SITES	\$ 1,000.00
01-B-03	NEW BUILDINGS & ADDITIONS	\$ -
01-B-04	UTILITIES - ADMINISTRATION BUILDING	\$ 15,000.00
01-B-05	MAINTENANCE, SUPPLIES & MATERIALS	\$ -
01-B-06	EQUIPMENT PURCHASES & REPLACEMENT	\$ -
01-b-07	REPAIRS	\$ -
01-B-08	OTHER EXPENSES	\$ -

TOTAL - 01-B	\$ 22,000.00
---------------------	---------------------

GENERAL: 01-C- FIRE PROTECTION		
01-C-02	EQUIPMENT PURCHASES & REPLACEMENT	\$ -
01-C-03	UTILITIES - FIRE	\$ 20,000.00

TOTAL - 01-C	\$ 20,000.00
---------------------	---------------------

GENERAL: 01-D - UNION CEMETERY		
01-D-08	CEMETERY EXPENSES	\$ -

TOTAL 01-D	\$ -
-------------------	-------------

GENERAL: 01-E - STREET LIGHTS		
01-E-01	STREET LIGHT CONTRACTS	\$ 3,000.00
01-E-03	STREET LIGHT OTHER	\$ -

TOTAL - 01-E	\$ 3,000.00
---------------------	--------------------

GENERAL: 01-F - PARK & IMAGINATION STATION		
01-F-01	SALARIES - MECHANIC	\$ 1,000.00
01-F-01-A	SALARIES - GROUNDSKEEPER	\$ 6,608.00
01-F-02	IMPROVEMENT OF SITES	\$ 12,500.00
01-F-04	NEW BUILDINGS & ADDITIONS	\$ -
01-F-04-A	NEW BUILDINGS - IMAGINATION STATION	\$ -
01-F-05	NEW TOOLS & EQUIPMENT	\$ -
01-F-06	SUPPLIES - PARK	\$ 2,500.00
01-F-07	REPAIRS & MAINTENANCE - PARK	\$ 500.00
01-F-08	OTHER EXPENSES	\$ 500.00
01-F-09	SPECIALS EVENTS AT PARK	\$ 1,000.00

TOTAL - 01-F		\$ 24,608.00
---------------------	--	---------------------

GENERAL: 01-G - POLICE PROTECTION		
01-G-02	EQUIPMENT & REPLACEMENT	\$ -
01-G-03	UTILITIES - POLICE	\$ 20,000.00

TOTAL - 01-G		\$ 20,000.00
---------------------	--	---------------------

GENERAL: 01-H - CONTRACTS		
01-H-06	CONTRACTS	\$ 1,000.00

TOTAL - 01-H		\$ 1,000.00
---------------------	--	--------------------

GENERAL: 01-K - HIGHWAY MAINTENANCE		
01-K-09	UTILITIES - ROAD	\$ 10,000.00

TOTAL - 01-K		\$ 10,000.00
---------------------	--	---------------------

GENERAL: 01-M - ROAD		
01-M-03	CONTRACTS - PAVING	\$ -

TOTAL - 01-M		\$ 10,000.00
---------------------	--	---------------------

GENERAL: 01-N - ADVANCES OUT		
01-N	ADVANCES OUT	\$ -

TOTAL - 01-N		\$ -
---------------------	--	-------------

MOTOR VEHICLE: 02		
02-B-02	MATERIALS - SALT - SAND	\$ 26,509.88
02-B-03	CONTRACTS	\$ -
TOTAL - 02		\$ 26,509.88

GASOLINE TAX: 03-A, 03-B AND 03-C		
03-A-04	TOOLS & EQUIPMENT	\$ 27,500.00
03-A-05	SUPPLIES	\$ 22,500.00
03-A-06	REPAIRS	\$ 22,500.00
03-A-07	MAINTENANCE OF EQUIPMENT	\$ 22,500.00
03-B-02	MATERIAL	\$ 22,500.00
03-B-04	OTHER EXPENSES	\$ 17,941.10
03-C-03	CONTRACTS	\$ 15,500.00
TOTAL - 03		\$ 150,941.10

ROADS & BRIDGES: 04-A, 04-B AND 04-C		
04-A-02	EMPLOYER'S RETIREMENT CONTRIBUTION	\$ 20,500.00
04-A-03	WORKMEN'S COMPENSATION	\$ 5,700.74
04-A-04	TOOLS & EQUIPMENT	\$ 500.00
04-A-05	SUPPLIES	\$ 2,039.85
04-A-06	REPAIRS	\$ -
04-A-07	MAINTENANCE OF EQUIPMENT	\$ -
04-A-08	BUILDINGS & ADDITIONS	\$ -
04-A-10	INSURANCE	\$ 76,000.00
04-A-13	OTHER EXPENSES	\$ -
04-A-14	TRANSFERS	\$ -
04-A-15	AUDITOR'S & TREASURER'S FEES	\$ 3,500.00
04-A-90	FICA/MEDICARE - EMPLOYER'S SHARE	\$ 1,500.00
04-B-01	SALARIES	\$ 143,965.68
04-B-02	MATERIAL	\$ -
04-B-03	CONTRACTS	\$ 2,000.00
04-B-04	OTHER EXPENSES - MAINTENANCE	\$ -
04-C-04	OTHER EXPENSES	\$ -
TOTAL - 04-A, 04-B AND 04-C		\$ 255,706.27

CEMETERY: 05		
05-A-01	SALARIES - MOWING	\$ 16,131.22
05-A-02	SALARIES - BURIALS & CEMETERY SEXTON	\$ 7,948.22
05-A-02-A	SALARIES - CLERICAL	\$ 4,000.00
05-A-03	EMPLOYER'S RETIREMENT CONTRIBUTION	\$ 3,000.00
05-A-04	WORKMEN'S COMPENSATION	\$ 1,850.11
05-A-05	IMPROVEMENT OF SITES	\$ -
05-A-06	LAND PURCHASES	\$ -
05-A-07	REPAIRS & MAINTENANCE	\$ 1,000.00
05-A-08	TOOLS & EQUIPMENT	\$ 500.00
05-A-09	SUPPLIES	\$ 1,817.00
05-A-12	OTHER EXPENSES	\$ 500.00
05-A-12A	INSURANCE	\$ 1,800.00
05-A-13	UNEMPLOYMENT COMPENSATION	\$ 4,200.00
05-A-90	FICA/MEDICARE - EMPLOYER'S SHARE	\$ 500.00

TOTAL - 05		\$ 43,246.55
-------------------	--	---------------------

CEMETERY BEQUEST: 06		
06-A-01	EXPENDITURES - NON-RESTRICTED	\$ 4,045.88

TOTAL - 06		\$ 4,045.88
-------------------	--	--------------------

LIGHTING ASSESSMENT - IVY HILL: 07

07-A-01	LIGHTING CONTRACTS	\$	2,882.91
07A-02	OTHER EXPENSES (SALARY / AUDITOR FEES/MISC.)	\$	100.00

TOTAL - 07		\$	2,982.91
-------------------	--	-----------	-----------------

LIGHTING ASSESSMENT - MORROW & WILLIAMS DRIVES: 07-A

07-A-01-A	LIGHTING CONTRACTS	\$	2,427.55
07-A-02-A	OTHER EXPENSES (SALARY / AUDITOR FEES/MISC.)	\$	100.00

TOTAL - 07-A		\$	2,527.55
---------------------	--	-----------	-----------------

LIGHTING ASSESSMENT - TIMBER CREEK HEIGHTS: 07-B

07-A-01-B	LIGHTING CONTRACTS	\$	1,573.93
07-A-02-B	OTHER EXPENSES (SALARY / AUDITOR FEES, MISC.)	\$	100.00

TOTAL - 07-B		\$	1,673.93
---------------------	--	-----------	-----------------

LIGHTING ASSESSMENT - TIMBER CREEK ESTATES: 07-C

07-A-01-C	LIGHTING CONTRACTS	\$	5,664.95
07-A-02-C	OTHER EXPENSES (SALARY / AUDITOR FEES, MISC.)	\$	100.00

TOTAL - 07-C		\$	5,764.95
---------------------	--	-----------	-----------------

POLICE DISTRICT: 09		
09-A-01	SALARIES (FULL TIME)	\$ 302,229.50
09-A-01-A	SALARIES - OVERTIME (FULL TIME)	\$ 50,099.20
09-A-01-B	SALARIES - (PART TIME)	\$ 55,800.00
09-A-01D	SALARIES - MECHANIC	\$ 8,900.00
09-A-02	EMPLOYER'S RETIREMENT CONTRIBUTION	\$ 87,767.38
09-A-03	WORKMEN'S COMPENSATION	\$ 17,594.20
09-A-04	AUDITOR'S & TREASURER'S FEES	\$ 10,000.00
09-A-07	TOOLS & EQUIPMENT	\$ 20,840.07
09-A-08	SUPPLIES	\$ 16,000.54
09-A-09	BUILDING IMPROVEMENTS	\$ -
09-A-10	CONTRACTS	\$ 41,503.08
09-A-12	INSURANCE	\$ 114,030.09
09-A-12-A	TRANSFERS	\$ -
09-A-13	TRAINING	\$ 6,000.00
09-A-14	OTHER EXPENSES	\$ 155,497.64
09-A-15-A	UNEMPLOYMENT COMPENSATION	\$ -
09-A-90	FICA/MEDICARE - EMPLOYER'S SHARE	\$ 5,932.94

TOTAL - 09		\$ 892,194.64
-------------------	--	----------------------

POLICE DISTRICT EQUIPMENT: 09-C		
09-A-04-C	TOOLS & EQUIPMENT	\$ 36,742.04
09-A-05-C	SUPPLIES	\$ 22,000.00
09-A-06-C	REPAIRS	\$ 16,000.00
09-A-08-C	AUDITOR'S & TREASURER'S FEES	\$ 900.00
09-A-10-C	CONTRACTS	\$ -

TOTAL - 09-C		\$ 75,642.04
---------------------	--	---------------------

POLICE - O.M.V.I.: 09-J		
09-J	OTHER	\$ 306.00

TOTAL - 09-J		\$ 306.00
---------------------	--	------------------

FIRE DISTRICT: 10-A & 10-C		
10-A-01	SALARIES (FULL TIME)	\$ 454,800.43
10-A-01-A	SALARIES (PART TIME)	\$ 161,734.85
10-A-01-B	SALARY - MECHANIC	\$ 8,000.00
10-0A-02	EMPLOYER'S RETIREMENT CONTRIBUTION	\$ 127,929.70
10-Q-03	WORKMEN'S COMPENSATION	\$ 33,393.14
10-A-04	AUDITOR'S & TREASURER'S FEES	\$ 12,000.00
10-A-06	NEW BUILDINGS & EQUIPMENT	\$ -
10-A-07	UTILITIES	\$ 7,000.00
10-A-08	TOOLS & EQUIPMENT	\$ 83,240.00
10-A-09	SUPPLIES	\$ 15,000.00
10-A-10	REPAIRS	\$ 10,000.00
10-A-11	TRAINING	\$ 5,000.00
10-A-14	INSURANCE	\$ 147,164.00
10-A-14-A	CONTRACTS	\$ 2,000.00
10-A-15	OTHER EXPENSES	\$ 500.00
10-A-17	TRANSFERS	\$ -
10-A-90	FICA/MEDICARE - EMPLOYER'S SHARE	\$ 25,000.00
10-C-05	EMS - SUPPLIES	\$ 10,000.00
10-C-06	EMS - REPAIRS	\$ 5,000.00
10-C-07	EMS - CONTRACTS	\$ 22,000.00
10-C-08	EMS - OTHER EXPENSES	\$ 5,000.00

TOTAL - 10-A & 10-C	\$ 1,134,762.12
--------------------------------	------------------------

ZONING: 13		
13-A-01	SALARIES & FEES	\$ 9,456.48
13-A-02	OTHER EXPENSES	\$ 3,000.00
13-A-03	SUPPLIES	\$ 1,000.00

TOTAL - 13	\$ 13,456.48
-------------------	---------------------

FIREFIGHTERS ASSISTANCE: 14		
14-A-07	TOOLS & EQUIPMENT	\$ 1,000.00

TOTAL - 14	\$ 1,000.00
-------------------	--------------------

FEMA: 14-A		
14-A-07-A	EXPENDITURES - REIMBURSEMENTS	\$ -

TOTAL - 14-A	\$ -
---------------------	-------------

GENERAL BOND / NOTE RETIREMENT: 15		
15-A-01	FIRE EQUIPMENT (PRINCIPLE & INTEREST)	\$ 64,775.65
15-A-01-A	ROAD EQUIPMENT (PRINCIPLE & INTEREST)	\$ -
15-A-01-B	POLICE EQUIPMENT (PRINCIPLE & INTEREST)	\$ 50,138.17
15-A-04	INTEREST	\$ 6.27
TOTAL - 15		\$ 114,920.09

DRUG ENFORCEMENT: 22		
22-A-01	DRUG ENFORCEMENT	\$ 873.46
TOTAL - 22		\$ 873.46

PERMISSIVE LICENSE PLATE TAX: 23		
23-A-90	FICA/MEDICARE - EMPLOYER'S SHARE	\$ -
TOTAL - 23		\$ -

PERMANENT IMPROVEMENT: 26		
26-A-06	SUPPLIES	\$ -
TOTAL - 26		\$ -

ISSUE II - IMPROVEMENT: 30		
30-A-05-A	CAPITAL EXPENDITURES - TOWNSHIP	\$ -
30-A-06	CAPITAL EXPENDDITURES - O.P.W.C.	\$ -
30-A-09	OTHER EXPENSES	\$ -
TOTAL - 30		\$ -

RECAPITULATION OF FUNDS - 2006

FUND 01	GENERAL: 01-A	\$ 417,611.39
	GENERAL: 01-B - TOWN HALL, MEMORIAL BUILDINGS & GROUNDS	\$ 22,000.00
	GENERAL: 01-C - FIRE PROTECTION	\$ 20,000.00
	GENERAL: 01-D - UNION CEMETERY	\$ -
	GENERAL: 01-E - STREET LIGHTS	\$ 3,000.00
	GENERAL: 01-F - PARK & IMAGINATION STATION	\$ 24,608.00
	GENERAL: 01-G - POLICE PROTECTION	\$ 20,000.00
	GENERAL: 01-H - CONTRACTS	\$ 1,000.00
	GENERAL: 01-K - HIGHWAY MAINTENANCE	\$ 10,000.00
	GENERAL: 01-M - ROAD	\$ -
	GENERAL: 01-N - ADVANCES OUT	\$ -
	TOTAL - GENERAL FUND 01	\$ 518,219.39

FUND 02	MOTOR VEHICLE: 02	\$ 26,509.88
FUND 03	GASOLINE TAX: 03-A, 03-B AND 03-C	\$ 150,941.10
FUND 04	ROADS & BRIDGES: 04-A, 04-B AND 04-C	\$ 255,706.27
FUND 05	CEMETERY: 05	\$ 43,246.55
FUND 06	CEMETERY BEQUEST: 06	\$ 4,045.88
FUND 07	LIGHTING ASSESSMENT - IVY HILL: 07	\$ 2,982.91
FUND 07-A	LIGHTING ASSESSMENT - MORROW & WILLIAMS DRIVES: 07-A	\$ 2,527.55
FUND 07-B	LIGHTING ASSESSMENT - TIMBER CREEK HEIGHTS: 07-B	\$ 1,673.93
FUND 07-C	LIGHTING ASSESSMENT - TIMBER CREEK ESTATES: 07-C	\$ 5,764.95
FUND 09	POLICE DISTRICT: 09	\$ 892,194.64
FUND 09-C	POLICE DISTRICT EQUIPMENT: 09-C	\$ 75,642.04
FUND 09-J	POLICE - O.M.V.I.: 09-J	\$ 306.00
FUND 10	FIRE DISTRICT: 10-A & 10-C	\$ 1,134,762.12
FUND 13	ZONING: 13	\$ 13,456.48
FUND 14	FIREFIGHTERS ASSISTANCE: 14	\$ 1,000.00
FUND 14-A	FEMA: 14-A	\$ -
FUND 15	GENERAL BOND / NOTE RETIREMENT: 15	\$ 114,920.09
FUND 22	DRUG ENFORCEMENT: 22	\$ 873.46
FUND 23	PERMISSIVE LICENSE PLATE TAX: 23	\$ -
FUND 26	PERMANENT IMPROVEMENT: 26	\$ -
FUND 30	ISSUE II - IMPROVEMENT: 30	\$ -

TOTAL ALL FUNDS	\$ 3,244,773.24
------------------------	------------------------

NOTE: AUDITOR'S CERTIFICATE DATED 1/27/06 SHOWS	
FUND 15 AS \$114,920.49	
OUR FIGURES SHOW \$114,920.09 - DIFFERENCE OF .40)	\$ (0.40)

\$ 3,244,772.84

2006 PERMANENT APPROPRIATIONS
MARCH 20, 2006 - RESOLUTION #77-06

BAZETTA TOWNSHIP REGULAR MEETING MINUTES
APRIL 03, 2006
9:00 AM

Present: Trustees Bill Glancy, Mike Piros and Jeff Bates.

Mr. Glancy opened the meeting and then relinquished it to Mr. Piros due to Mr. Glancy having a cold.

Mr. Piros said he was going to deviate from the regular agenda as one of the Trustees needs to leave early due to his work schedule.

Old Business:

Mr. Bates mentioned he and department heads along with Mr. Mauger had a meeting with representatives from Murphy Oil who are the contractors for the Wal-Mart gas station and agreed to their proposal plans. Mr. Glancy also had a meeting with Aqua Water Company and at that time the Trumbull County Commissioners agreed to a pilot project with several pattern plans being placed in the township. This is only a trial basis for now.

Mr. Piros is meeting today at 10:30 AM with an electrical contractor for a bid to install electricity at the township park gazebo. He contacted three and only one has responded. He will have a complete report for the next meeting.

Police Chief Sayers:

Chief Sayers requested permission to purchase two used radar units from Midwest Radar at a total cost of \$710.

82-06 Motion by Mr. Piros, seconded by Mr. Glancy to purchase two used radar units from Midwest Radar at the total cost of \$710.

Vote on Motion: Mr. Bates YES, Mr. Glancy YES and Mr. Piros YES.

YES 3

NAY 0

Motion Carried.

83-06 Motion by Mr. Bates, seconded by Mr. Glancy to purchase 12 Impact Plates for bulletproof vests from Red Diamond at a total cost of \$779.88.

Vote on Motion: Mr. Bates YES, Mr. Glancy YES and Mr. Piros YES.

APRIL 03, 2006

YES 3

NAY 0

Motion Carried.

84-06 Motion by Mr. Glancy, seconded by Mr. Bates to purchase evidence room software and barcode equipment from Total Solutions for a total cost of \$822.45.

Vote on Motion: Mr. Bates YES, Mr. Glancy YES and Mr. Piros YES.

YES 3

NAY 0

Motion Carried.

Janet Perhach, 2417 Northview Drive, expressed her appreciation to Chief Sayers and his department for their vacation watch.

Fire Chief McKenzie:

85-06 Motion by Mr. Glancy, seconded by Mr. Bates to purchase through state purchasing a 2006 Ford E350 Super Duty XL Citimedic 138 Wheeled Coach Emergency Vehicle to replace the one that was damaged in an accident on State Route 5 on December 20, 2005.

Vote on Motion: Mr. Bates YES, Mr. Glancy YES and Mr. Piros YES.

YES 3

NAY 0

Motion Carried.

Chief McKenzie stated that the committee looked at many replacement vehicles, but the one that was wrecked was this same model and they felt the impact it handled with the roll over with just minor injuries was the best way to go.

Chief McKenzie also asked the Trustees to sign a letter he wrote supporting House Bill 401 regarding maintaining comprehensive fire training programs for both the EMTs and the Firefighters side.

86-06 Motion by Mr. Glancy, seconded by Mr. Bates to sign the letter in support of House Bill 401 regarding maintaining comprehensive fire training programs for both the EMTs and the Firefighters side.

Vote on Motion: Mr. Bates YES, Mr. Glancy YES and Mr. Piros YES.

APRIL 03, 2006

YES 3

NAY 0

Motion Carried.

Mr. Glancy complimented the Chief and his department on the survey that was mailed to residents as well as non-residents on the service they received from the fire department in their time of need.

Assistant Road Superintendent Kris Parke:

Mr. Parke distributed his monthly report to the Trustees.

As requested by the Trustees, he contacted Russ Lowry regarding a set of prints for the township park.

Mr. Bates asked for the two letters that were sent to the City of Cortland on the deficit of the cemetery for 2005. Kris will again copy them and give them to Mr. Bates.

Zoning Inspector Mauger:

Mr. Mauger presented his monthly report to the Trustees. He said the property at 2466 Northview Drive should be cleaned up within a week.

The next project is a house on State Route 305, but has no house number to report at this time.

Safety Committee:

Chief Sayers had nothing to report.

Administration:

Mr. Piros reminded everyone of the following dates:

Saturday, April 08th at 11:00 AM is the Easter Egg Hunt at the township park.

The meeting time change for the next regular meeting on Monday, April 17th will be at 9:00 AM instead of 7:00 PM due to a schedule conflict.

April 27th through April 30th is the Township Free Garage Sale.

Saturday, May 06th from 8:00 AM to 4 PM is spring clean up held at the road department.

APRIL 03, 2006

87-06 Motion by Mr. Bates, seconded by Mr. Glancy to rehire Jack Governor, part-time summer help at the park, for 20 hours a week at his current rate of pay, \$9.53 per hour, effective March 27, 2006. His hours will be 9:00 AM until 1:00 PM, Monday through Friday.

Vote on Motion: Mr. Bates YES, Mr. Glancy YES and Mr. Piros YES.

YES 3

NAY 0

Motion Carried.

The following bids were opened for the demolition of 3054 North Park Avenue:

\$6,400.00	Jimco, LLC, Ashtabula, Ohio
\$4,990.00	Westbay & Sons, Cortland, Ohio
\$3,850.00	Steel Valley Construction, Inc., Warren, Ohio
\$3,500.00	L. Lynne Maintenance, LLC, Southington, Ohio
\$2,650.00	Z-Tech Builders & Excavators, Cortland, Ohio

88-06 Motion by Mr. Bates, seconded by Mr. Glancy to accept the bid from Z-Tech Builders & Excavators for \$2,650 pending all requirements are met with the Health Department as well as the county.

Vote on Motion: Mr. Bates YES, Mr. Glancy YES and Mr. Piros YES.

YES 3

NAY 0

Motion Carried.

Mr. Piros asked the Fiscal Officer to contact Mr. Zuga of Z-Tech regarding the above mentioned requirements.

Mr. Bates suggested we table at this time placing people for community service through the Trumbull County Job and Family Services.

The Trustees set the date of April 17, 2006 at 8:45 AM for the zone change hearing from residential to commercial filed by Jesse and Cindy Matheson for the property located at 2489 Niles Cortland Road. Mr. Piros asked the Fiscal Officer to notify the property owners as well as place an ad in the newspaper for the time, date and place of the hearing.

89-06 Motion by Mr. Glancy, seconded by Mr. Bates to authorize the Fiscal Officer to transfer \$500 within funds from Cemetery 05-A-07 (Repairs & Maintenance) to Cemetery (Supplies) 05-A-09.

Vote on Motion: Mr. Bates YES, Mr. Glancy YES and Mr. Piros YES.

APRIL 03, 2006

YES 3

NAY 0

Motion Carried.

Due to his work schedule, Mr. Bates left the meeting at 9:40 AM.

At this time, Bob Kubiak, of the Children's Services spoke about the wide range of services his agency provides and passed out flyers to everyone present and asked their support in the renewal levy on the May 02nd ballot. It was originated in 1986 and is for 2M. This being a renewal will not increase the property owner's tax amount.

Public Participation:

Pearlene and Tom Lyman, 2440 Westview Drive, requested a sewer petition for their street and asked about water. Mr. Piros gave them both a sewer and water petition and explained they need to get 80% of the residents to sign each form, then it is sent to the sanitary engineer who gives it to the commissioners and they do a feasible study on the costs, then the sanitary engineer sets up a public meeting with the residents to find out their costs per foot which can be accessed to their taxes for 20 years. At the public meeting the residents can either say yes or no. If yes, the sanitary engineer can start the process. Mr. Glancy mentioned this is not a quick process.

Mrs. Lyman told the Trustees she appreciated the spring flyer and to keep up the good work.

Fred Grinnell, 2408 Westview Drive, asked where the new development on McCleary Jacoby Road will get their water and sewer. Mr. Mauger said the water will be furnished by Trumbull County and will come along the frontage of the Ross' house and the sewer will come from the rear of the development along the creek and it will also come from Trumbull County. The developer will pay for these upfront and will recoup his money by selling the lots.

Mr. Glancy spoke of the letter he wrote to the Board of Health on the sewage system that was put in the front yard of a house on Bazetta Road and sticks up at least 5' above the ground. He said the nearby homeowners requested a meeting with the township Trustees and the Board of Health. Mr. Glancy said the Trustees supports the homeowners' concerns that the value of their home decreased \$25,000 and suggested everyone to attend the Health Board meetings, as there is power in numbers.

Mr. Grinnell suggested that Mr. Mauger get more involved and put this in the Zoning Book. For example, issue permits for septic systems in the township and then inspect them.

Mr. Glancy said the township has no legal recourse on septic tanks and like the gas well drilling; this is regulated by the state, not the township.

APRIL 03, 2006

Mr. Piros interjected that his board is on top of what we can do legally.

Mr. Piros also mentioned the Lakeshore Drive area where the homeowners signed a sewer petition and then was sent a letter from the Health Department requiring them to upgrade their system. This Board met with the Health Department and got a reprieve as their petition was already in the works but any new petitions, this Board can't say the Health Department will do the same.

Mr. Grinnell asked Mr. Glancy where the water would be purchased from and the reply was from the City of Warren or Trumbull County, even though the body of water sits in our township as well as the treatment plant.

Steve Perhach, 2417 Northview Drive, asked where the water pilot will be placed. Mr. Glancy did not know for sure. Mr. Perhach asked if it is the same policy, if you don't tap in, you don't pay. Mr. Glancy said yes.

Janet Perhach, 2417 Northview Drive, asked if both lines could be dug at the same time and Mr. Piros said no because of the unions involved plus the water would be a private company and the sewer would be the county.

Mrs. Lyman, 2440 Westview Drive, asked after the new development is done, would the developer turn the sewer over to the county. Mr. Piros said he believed it would be turned over to the county.

Kris Parke said that the county has the say so as to what size pipe is put in according to the number of homes being built. Mrs. Lyman asked if the developer could put in a larger size pipe so Westview could benefit from it. Mr. Piros said that would be up to the developer and the county sanitary engineer.

Fred Grinnell, 2408 Westview Drive, asked if there is a map of places requesting sewer. Mr. Piros asked about that himself and was told the sewer district was developed in the late 1950's or early 1960's and requested they develop a new sewer district as things have changed since the 1960's.

Mr. Glancy said there is a sewage plant by the fairgrounds and the residents of Lakeshore Drive can't tap in. They will need to upgrade Sterling Drive sewage plant and eventually tap into Sterling Drive sewage plant. Now the State Park wants to tap in too so the study has to be re-engineered.

Mr. Grinnell continued by asking if there is a standard septic tank and if a soil test is done as there is no more off lot systems anymore.

APRIL 03, 2006

Mr. Piros answered that he felt the residents who are forced to put in new systems and then a sewage system is put in, that the Health Department and the county should see that the residents recoup some of their monies. He has written letters to the local and state representatives about his concerns.

90-06 Motion by Mr. Glancy, seconded by Mr. Piros to approve the minutes of the March 20th meeting.

Vote on Motion: Mr. Glancy YES and Mr. Piros YES.

YES 2

NAY 0

Motion Carried.

The following correspondence was read:

1. Sunburst was called to resume garbage pick up at the park effective April 01st and also Trumbull County Sewer was called to resume sewer services effective April 01st.
2. An email was sent to the Tribune, Cortland News and the Review of last meeting's agenda.
3. An email was received from Darlene St. George on Ohio Townships Legislative Updates.
4. Received an invitation from Trumbull Memorial Hospital for new facility dedication on April 04th. This was passed onto the Trustees.
5. Received a letter from Trumbull County Farm Bureau to become a member.
6. Received a letter from Trustees to Dr. Enyeart on neighbor's concerns surrounding the 3200 Bazetta Road property on the newly installed septic system.
7. Invitation from Trumbull EMA on a community emergency management utilizing in a planned development process to be held on April 04th at St. Elizabeth's Hospital. This was passed on to the Trustees.
8. Received a letter from State Representative Randy Law to the Trustees appreciating our letter to him on Senate Bill 191 on mining operations.
9. Trumbull County Local Emergency Planning Committee will be conducting a "NIMS" IS-700 class for newly elected officials or any other official in need of this training. This will take place on April 12th at the EMS/LEPC offices at the airport.

APRIL 03, 2006

10. Letter from Attorney Finamore on preparing legal notices and procedures for petition for lighting district.
11. Letter from Attorney Finamore for resolution and policy of compliance with public record law.
12. Letter from State Senator Marc Dann stating he is in support of House Bill 23, which gives the townships the authority they need to regulate adult-oriented businesses in order to protect the community.
13. Letter of Buckeye Energy Brokers, Inc. who manages natural gas prices.

Mr. Piros made comment to Mr. Mauger that the letter from Senator Dann on adult oriented businesses to be forwarded to the Zoning Board.

Mr. Mauger said he would give this letter to the Zoning Board at their quarterly meeting here on Wednesday, April 05th at 7:00 PM.

Mr. Piros also commented on gas aggregation rates through the Buckeye Energy Brokers stating that Howland went with this company for six months (May through October, 2006) and now East Dominion Gas has lowered their rates and now Howland is locked in with Buckeye Energy Brokers at a higher rate. Mr. Piros went on to say the Board would look at this again in August or September for the next period of six months (November through April, 2007).

91-06 Motion by Mr. Glancy, seconded by Mr. Piros to approve the purchase orders.
Vote on Motion: Mr. Glancy YES and Mr. Piros YES.

YES 2

NAY 0

Motion Carried.

92-06 Motion by Glancy, seconded by Mr. Piros to approve the payment of bills.
Vote on Motion: Mr. Glancy YES and Mr. Piros YES.

YES 2

NAY 0

Motion Carried.

Mr. Piros asked the board to look over the new zoning manual and make any corrections, additions or deletions. Mr. Piros suggested instead of copying this 90 page plus manual that we look into getting it printed double sided to reduce the size of the booklet. Mr. Piros will have

APRIL 03, 2006

price quotes at the next meeting.

Mr. Grinnell, 2440 Westview Drive, asked if the board would consider having the vocational school do the printing of the zoning manual at a lower cost. Mr. Piros said yes it would be less costly, but the time frame might not be until September and the zoning manual needs to be printed as soon as possible as we have added fencing and deleted several items.

Rex Pealer, 3430 Warren Meadville Road, asked if anything has been done about the dangerous intersection of Warren Meadville Road and McCleary Jacoby Road. Mr. Piros replied that the county engineer's office sent us a letter stating extra stop signs along with "stop ahead" signs were placed on McCleary Jacoby Road. Mr. Pealer would like to go on record stating this is a dangerous intersection and asked the Trustees to put more pressure on the county engineer's office to avoid more accidents.

93-06 Motion by Mr. Glancy, seconded by Mr. Piros to adjourn the meeting.
Vote on Motion: Mr. Glancy YES and Mr. Piros YES.

YES 2

NAY 0

Motion Carried.

ATTEST

BAZETTA TOWNSHIP REGULAR MEETING MINUTES
APRIL 17, 2006
9:00 AM

Present: Trustees Bill Glancy, Mike Piros and Jeff Bates.

8:45 AM on Monday, April 17, 2006.

Public zoning hearing was held for property located at 2489 Niles Cortland Road to be changed from residential to commercial.

Owners Cindy Matheson, 5335 Bazetta Road, Cortland and Jesse Matheson of 3065 Fallehn Drive, Cortland were present and spoke in favor of this change. They stated this zone change is to house Howland Alarm System for offices only and to be open from 9-5 Monday through Friday. All the alarm work would be done outside of this office. They also requested to place a sign in front of the building.

Mr. Piros asked three times who opposed this change. There was no opposition to this zone change.

Mr. Piros stated if there is no further discussion, this would be tabled for the 9:00 AM meeting to follow.

The hearing is now over.

Mr. Glancy opened the regular meeting. He welcomed the students from Lakeview's Government Classes.

Due to Mr. Glancy's recent bout with the flu, he asked Vice Chairman, Mike Piros, to chair this meeting.

94-06 Motion by Mr. Glancy, seconded by Mr. Bates to approve the minutes of the April 03rd meeting.

Vote on Motion: Mr. Bates YES, Mr. Glancy YES and Mr. Piros YES.

YES 3

NAY 0

Motion Carried.

The following correspondence was read:

APRIL 17, 2006

1. Letter from the Ohio Department of Transportation responding to our letter on the traffic signal for the new Super Wal-Mart with concerns from the car wash and the Harley Davidson Shop.
2. Letter to Mr. Glancy on the Blueprint Implementation Committee's next meeting on April 11th. This is the county's committee to end homelessness.
3. Trumbull County Soil and Water Conservation District regarding roadside signage.
4. Letter from Eastgate regarding the Round 4 of the Clean Ohio Conservation Fund.
5. Email from State Representative Randy Law on the next meeting on the Mosquito Lake Lodge meeting on April 20th.
6. An email was sent to Cortland News and the Tribune on the minutes from the last meeting, and also an ad for the zone change public hearing at 8:45 AM on April 17th on 2489 Niles Cortland Road that was changed from residential to commercial.
7. Received monthly report for March, 2006 from the fire department.
8. Received 2005 Annual Report from Eastgate Regional Council of Governments.
9. Mahoning Valley BWC May 10th Breakfast – one of the Trustees should attend for us to qualify for BWC premium discount for 2006.
10. Board of Health Regular Meeting minutes of March 15th and Board of Health Meeting agenda for next meeting April 19th at the Warren Township Administration Building at 7:00 PM.
11. Letter from Mayor Curt Moll on the addition of a decorative fence and improvement for an entrance at Casterline Cemetery which was discussed and approved at their Council meeting on April 03rd.
12. Letter from a resident asking who is responsible for the roadway between the railroad tracks on Route 305 just west of Route 5.
13. Letter to Trustees from State Representative Sandra Stabile Harwood thanking us for our letter to her voicing our concerns and opposition to Senate Bill 191 regarding mining operations.
14. Fax from Congressman Tim Ryan on Household Water Well System Grant Program.

APRIL 17, 2006

95-06 Motion by Mr. Bates, seconded by Mr. Glancy to approve purchase orders.

Vote on Motion: Mr. Bates YES, Mr. Glancy YES and Mr. Piros YES.

YES 3

NAY 0

Motion Carried.

96-06 Motion by Mr. Glancy, seconded by Mr. Bates to approve payment of bills.

Vote on Motion: Mr. Bates YES, Mr. Glancy YES and Mr. Piros YES.

YES 3

NAY 0

Motion Carried.

Mr. Piros mentioned there was a public zoning hearing at 8:45 AM today on property located at 2489 Niles Cortland Road to be rezoned from residential to commercial.

97-06 Motion by Mr. Glancy, seconded by Mr. Bates to accept the Zoning Board request to change the zoning from residential to commercial at 2489 Niles Cortland Road effective today, April 17th with a 30 day grace period for any challenges. For the record, May 17th will be the effective date.

Vote on Motion: Mr. Bates YES, Mr. Glancy YES and Mr. Piros YES.

YES 3

NAY 0

Motion Carried.

There was a discussion on the damaged cemetery stone that was moved from an out of state cemetery to Hillside. When unloading from our truck, it slipped and cracked. Mr. Glancy said we are not in the business to move stones; we should let a professional company do that. Mr. Piros asked Mr. Parke to get a price to replace this stone. Mr. Piros also asked Mr. Parke to contact Legal Counsel, Mark Finamore to write a letter that we will not move stones in the future.

Mr. Parke submitted estimated quotes from the Trumbull County Engineer's Office for street striping of five township streets (Burnett/Durst Clagg/Cadwallader Sonk/McCleary Jacoby and Howland Wilson) for a cost of \$5,291.71 and to sweep all township roads for a cost of \$993.30.

98-06 Motion by Mr. Bates, seconded by Mr. Glancy to accept the quotes from the Trumbull County Engineer's Office for striping five township street (Burnett/Durst Clagg/Cadwallader Sonk/McCleary Jacoby and Howland Wilson) for a cost of \$5,291.71 and to sweep all township

APRIL 17, 2006

roads for a cost of \$993.30.

Vote on Motion: Mr. Bates YES, Mr. Glancy YES and Mr. Piros YES.

YES 3

NAY 0

Motion Carried.

Mr. Parke mentioned that one of our men needs to accompany the county in sweeping the roads. Mr. Glancy said if this was done in the past, to do it again they year even though it will entail overtime hours.

There was a discussion on two laptops from Dell for \$1,614.20 which includes shipping. Mr. Bates suggested we table this until after the May 02nd election. Chief Sayers said he got a good price and that price might change.

There was a discussion on the sponsorship of a festival in the township park on September 21-24, 2006 to be sponsored by the Park Board and the Police Department and to enter into a contract for rides with Brown Amusement for this festival and a request for a donation from the General Fund of \$4,000 was tabled. Mr. Bates said this should be discussed over a work session. In the meantime, Chief Sayers is to discuss the contract with Brown Amusement with Legal Counsel, Mark Finamore and will have more information at the next meeting.

Mr. Piros reminded everyone of the free garage sale dates of April 27th through April 30th and of the township clean up day on Saturday, May 06th from 8:00 AM to 4:00 PM. Mr. Park asked if he could have four people work that day with Sunburst. He informed the public we get 30% back of the wages from the tire grant. Mr. Glancy said if this has been done in the past to go ahead and pay the four people overtime for that day.

There was a discussion on the drawing from David L. Rockman to run electric to the gazebo for \$860.

99-06 Motion by Mr. Bates, seconded by Mr. Glancy to accept the drawing only for \$860 and to be taken out of Fund 01-F-02 (Park).

Vote on Motion: Mr. Bates YES, Mr. Glancy YES and Mr. Piros YES.

YES 3

NAY 0

Motion Carried.

Mr. Parke submitted to the Trustees a bid from Calhoun Concrete for \$850 to build the ramp for the gazebo.

APRIL 17, 2006

100-06 Motion by Mr. Glancy, seconded by Mr. Bates to accept the bid from Calhoun Concrete for \$850 to build the ramp for the gazebo. This is to come out of Fund 01-F-02 (Park).

Vote on Motion: Mr. Bates YES, Mr. Glancy YES and Mr. Piros YES.

YES 3

NAY 0

Motion Carried.

Mr. Bates left the meeting at 9:30 AM.

We received one bid for the street lighting for Timber Creek Heights from Genesis of Akron for \$7,250. The township will buy the lights. A hearing will be held with these residents on the cost and at that time we will accept the bid from Genesis.

101-06 Motion by Mr. Glancy, seconded by Mr. Piros to authorize the Fiscal Officer to transfer \$7,558.50 from 10-A-01 (Fire Full Time Salaries) to 10-A-10 (Fire Repairs)

Vote on Motion: Mr. Glancy YES and Mr. Piros YES.

YES 2

NAY 0

Motion Carried.

Mr. Piros presented two quotes for the copying of the 85+ pages of the newly typed zoning manual.

Copy Center for copying 40 books	\$332.40
Howland Printing for copying 40 books	\$230.00 plus \$30 to bind them.

102-06 Motion by Glancy, seconded by Mr. Piros to accept the Howland Printing's quote of \$230 and the township will buy the three ring binders.

Vote on Motion: Mr. Glancy YES and Mr. Piros YES.

YES 2

NAY 0

Motion Carried.

There was a discussion on the proposal of a decorative fence from Youngstown Fence that Cortland City sent to us for the Casterline Cemetery. The total cost would be \$3,985 and our share would be \$1,992.50. This was tabled until Mr. Parke talks with Mr. Whitman of Cortland City about an entrance way into the cemetery.

APRIL 17, 2006

There was also a discussion on the letter sent to Cortland City on their share of the cemetery from July through December, 2005 for a total of \$17,945.42.

Mr. Parke asked the Trustees about how many times to mow the cemeteries. Mr. Piros said that is your responsibility to determine the workflow in your department. Mr. Piros suggested that Mr. Parke contact his department liaison, Jeff Bates.

There was a discussion on locking and unlocking of the township park restrooms. Mr. Parke is to contact Mr. Bates.

It was determined that Mr. Bates will open and close the office for Election Day on May 02nd.

Mr. Piros reminded everyone of the three levies on the ballot on May 02nd. Police 0.6M to provide and maintain police protection and general operating expenses and 1.8M to provide and maintain police equipment. Fire is 0.8M to provide and maintain fire equipment.

A public zoning hearing will be held on Monday, May 01, 2006 at 8:45 AM on changing from residential to commercial on property located at 3372 State Route 5 (Administration Building). Mr. Piros asked the Fiscal Officer to advertise.

103-06 Motion by Mr. Glancy, seconded by Mr. Piros to pass a resolution to continue with CorVel, our Managed Care Organization to run through May of 2007.
Vote on Motion: Mr. Glancy YES and Mr. Piros YES.

YES 2

NAY 0

Motion Carried.

Mr. Mauger mentioned that he received word that the bids for Super Wal-Mart have been set for June 21st instead of May 21st. They are still working with ODOT.

Mr. Mauger discussed the property at 3054 North Park and said that the trailer behind the burned house is not tied into the septic system.

104-06 Motion by Mr. Glancy, seconded by Mr. Piros to increase the bid of Z-Tech to \$2,900 as it was not stated in the newspaper article that the bidder had to put topsoil down and plant grass seed. His original bid was \$2,650 with a \$250 increase for topsoil and grass seed. This was still under the other bids we received.

Vote on Motion: Mr. Glancy YES and Mr. Piros YES.

APRIL 17, 2006

YES 2

NAY 0

Motion Carried.

Old Business:

Mr. Glancy had none.

Mr. Piros gave an update on his conversation with Gary Newbrough, Trumbull County Sanitary Engineer. Mr. Newbrough will be sending out letters to the residents of the east side sewer project for a public meeting sometime in late May to discuss the estimate of the sewer project cost. At that meeting the residents will have a chance to go with or without the sewer project. If they go with it, the county will go out for construction bids.

He also talked with Mr. Newbrough after residents on Westview Drive submitted petitions to be tied in with Stonegate and Mr. Newbrough felt this probably could be done if residents on Route 46 would sign a petition also.

He attended along with Chief Sayers and Chief McKenzie the mock disaster on Friday, April 14th at the air base. Other Trustees including Fowler, Vienna and Howland were also in attendance. One concern was that all three Trustees from the township where a disaster should happen need to be at the Command Center to make decisions. His concern is if he is needed at his house because of this disaster and can't go, can a representative be there in his place or in all three Trustees. This will be brought up with the Township Association at their next meeting.

Road Superintendent Frank & Kris Parke:

They had nothing to report.

Fire Chief McKenzie:

Chief McKenzie attended the BWC National Safety Council luncheon/meeting and presented to the Trustees a certificate for 100% for outstanding effort by supervisory personnel and employees in operating the entire year without a lost time injury. Both Mr. Glancy and Mr. Piros thanked the department heads and their employees for their extra support of this award.

Chief McKenzie submitted his Monthly Report to the Trustees.

Due to the resignation of part-time Firemen/EMT's in the last year and a half, he would like to hire more part-time employees to work the overtime hours to keep his salary costs down. He is starting to work his part-time people on a 12-hour shift from 8 AM to 8 PM. He would like to

APRIL 17, 2006

hire ten or more part-time employees in the near future.

Chief McKenzie asked the Trustees to hire one part-time Fireman/EMT, Jason Korpon, at a rate of \$9.50 per hour with the effective date of May 01, 2006 pending a drug screening test.

105-06 Motion by Piros, seconded by Mr. Glancy to approve the hiring of Jason Korpon at ~~\$9.50~~ per hour with the effective date of May 01, 2006 pending a drug screening test.

Vote on Motion: Mr. Glancy YES and Mr. Piros YES.

YES 2

NAY 0

Motion Carried.

*# 925
mju
5/3/06
see
Leo # 108-06*

Police Chief Sayers:

Chief Sayers mentioned he is Vice Chairman of the Local Emergency Planning Committee (LEP) and thanked Mr. Piros for taking the time to attend the Mock Disaster exercise on April 14th at the air base. He thought the drill went very well with tracking and mapping.

Chief Sayers presented a paper to the Trustees on phone solicitation starting in late April through July from the Cortland-Bazetta Fraternal Order of Police. This is legitimate in case any residents should call the township officials or offices. The solicitation is for various civic functions and causes but will primarily go towards our "Bats, Balls, and Badges" program that allows the organization to take 100 under privileged children to an Indians baseball game in July.

He also mentioned he will have extra radar on Bazetta Road along with two or three DUI checkpoints in the township.

Safety Committee:

There was nothing to report, but the safety programs are working.

Mr. Piros mentioned for the record that you do not need to hand in meal receipts. The procedure for travel and meals is outlined in our Travel Expense Reimbursement Policy. All credit cards are to be kept in this office in the safe.

Mr. Glancy mentioned to the department heads that the board would like to be notified when someone is attending training, on vacation, or out of town for any reason.

APRIL 17, 2006

Zoning Inspector:

Mr. Mauger stated the property at 2466 Northview is not yet cleaned up. He will send out a letter. He received another complaint about the trailers on Warren Meadville Road.

Mr. Mauger requested one of the trustees to go with him and look at 460 State Route #305.

Resident, Robert Niemi, 2787 Warren Meadville Road, commented on the sewage problems within the township. Residents can't buy or sell houses without putting aside \$20-25,000 for new septic tanks. He asked about grant money? Mr. Glancy said Bazetta doesn't qualify for any grant money because the total percent of income is too high. Mr. Glancy then pointed out the #1 priority with the Board of Health and the EPA is Lakeshore/Westlake Drive and we are working on that. Mr. Glancy also stated that sewage problems are countywide not just Bazetta. Mr. Glancy asked the residents to consider whom they vote for County Commissioner, and make sure their choice is the one who will help the townships with water and sewage.

Mr. Piros' concern is that when these residents put new septic tanks in and then a few years down the road, sewer comes along; he wants something in writing form the EPA or Board of Health stating they will get a moratorium for at least ten (10) years.

Mr. Glancy mentioned, the County Commissioners are voted in by the cities but do not represent them.

Mr. Piros wants the public to know that this Board is very active in our water and sewer problems within the township and will continue to work on these.

Mr. Piros mentioned that we received three (3) statements of professional design services for the addition to the police station to house the administrative offices, Jakubick/Sexton of Cortland, BIE out of Akron and MKC of New Philadelphia, OH. The board decided to go with Jakubick/Sexton as Ed Jakubick with the original architect.

106-06 Motion by Mr. Piros seconded by Mr. Glancy to accept the statement of professional design service qualifications from Jakubick/Sexton..

Vote on Motion: Mr. Glancy YES and Mr. Piros YES.

YES 2

NAY 0

Motion Carried.

APRIL 17, 2006

Mr. Piros will contact Mr. Jakubick to set up a work session/walk thru in the near future.

Mr. Piros asked the government students if they had any questions, and mentioned he will contract Superintendent Bob Wilson and maybe next year we could take our meeting to the high school. He thanked the students for their respect at the meeting. He will forward this comment on to their teacher, Tom Pavlansky.

107-06 Motion by Mr. Piros seconded by Mr. Glancy to adjourn the meeting.

Vote on Motion: Mr. Glancy YES and Mr. Piros YES.

YES 2

NAY 0

Motion Carried.

ATTEST

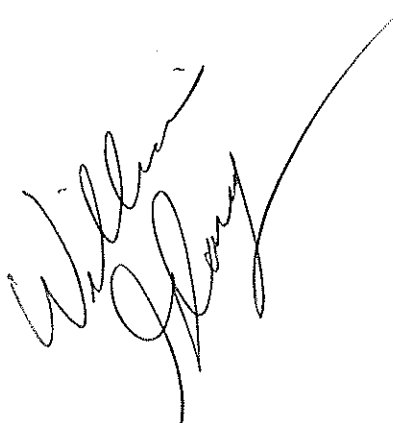
Handwritten signatures of Bob Wilson and Mr. Glancy. The signature of Bob Wilson is on the left, and the signature of Mr. Glancy is on the right, with a long horizontal line extending from the end of his signature.

BAZETTA TOWNSHIP REGULAR MEETING MINUTES
MAY 01, 2006
9:00 AM

Present: Trustees Bill Glancy, Mike Piros
Absent: Trustee Jeff Bates

At 8:45 AM a public zoning hearing was held for property located at 3372 State Route #5 to be changed from Residential (R-1) to Commercial (C-1).

Mr. Piros asked three times who was in favor of this change. There was no response.

Mr. Piros asked three times who opposed this change. There was no opposition to this zone change.

Being none, the board will take this under consideration at their regular meeting at 9 AM today.

Regular Meeting:

Due to Mr. Glancy still feeling under the weather, Mr. Piros will chair the meeting.

Old business:

Mr. Glancy challenged the bid from Calhoun Concrete, as it did not contain what the bid was for or the place where the work will be done. Mr. Piros said it was for the handicap ramp at the gazebo at the Park. Mr. Piros suggested that Mr. Parke and Martha design a form to be used throughout the township on bids.

Mr. Glancy made a comment on a letter he received from Dr. Enyeart, Trumbull County Health Commissioner on the Bioterrorism Planning Committee on May 24th. Chief McKenzie said he would be attending.

Mr. Glancy asked Mr. Mauger what he was doing about the junk cars at his neighbor's house. Mr. Mauger and Chief Sayers will look into this.

Mr. Piros asked Martha to contact Frank O'Brien from Ohio Edison if the bid we received in October 2005 for the street lighting at Timber Creek Heights would still be honored. If not, have him send an updated bid. Mr. Piros will then send out a letter to the Timber Creek Heights residents for a public hearing on the total cost of streetlights.

Mr. Piros read an email from Mauro Cantalamessa who is a candidate for the Trumbull County Commissioner.

MAY 01, 2006

Mr. Piros commented on an email he received from the Ohio Township Association on National Cable bill. He asked the fiscal officer to fax our opposition to our representatives ASAP, as they are to vote on this on May 4th.

Mr. Piros also announced that there will be a Candidate Night at Southington Township in August which will be sponsored by the Trumbull County Trustees Association.

Fred Hoover, 2282 State Route #5 questioned the zoning change for the administration building, which he opposes because he feels residential should stay residential so that we can protect our property. Mr. Piros answered that most of the properties along State Route #5 are commercial and this property should have been re-zoned a long time ago.

Mr. Hoover also asked why we are moving the offices to the police station and why we need to hire an architect. Mr. Piros replied that we hired the same architect that originally designed the police station and the reason is we need an approved architectural drawing being that we are a public entity. We will get free gas, plus share electrically, telephone, insurance, and secretarial services. We only need to expand the meeting room and selling or leasing this property will offset the cost of the addition.

108-06 Motion by Mr. Glancy, seconded by Mr. Piros to approve the minutes of the April 17th meeting after correction to resolution 105-06.

Vote on Motion: Mr. Glancy YES and Mr. Piros YES.

YES 2

NAY 0

Motion Carried.

The following correspondence was read:

1. Letter from Trumbull County Soil and Water Conservation District on property located on State Route #305 for a disturbance on a wetland area.
2. Letter from Clemans-Nelson & Associates for a Teamsters Fact Finding hearing to be held on May 25th at 10:00 AM -location TBD.
3. Grassroots Clippings, a monthly newsletter of the Ohio Township Association. A copy was given to all trustees.
4. Letter from Dr. Enyeart, TC Health Commission asking for any festival dates to apply for a temporary food license. Copies were given to trustees and Police Chief.

MAY 01, 2006

5. Letters received from Attorney's Curtis J. Ambrosy and Gilbert Rieger for the Four Seasons Car Wash, and Warren Harley Davidson Shop respectively asking us to include their clients for any meetings with Super Wal-Mart representatives.
6. Letter from Dr. Enyeart, Trumbull County Health Commissioner inviting the trustees to a "Tabletop Meeting" on May 24th at St. Joseph's Health Center on emergency responder coordination.
7. Letter from Attorney Gessner on the petition annexation hearing to be on April 26th on property owned by Russell and Shirley Lauer at 3583 State Route #5. (copy to trustees)
8. Fiscal Officer emailed meeting minutes to Cortland News and the Review.
9. Fiscal Officer attended a meeting on April 20th on the Mosquito Lake Lodge where Mr. Bill Letson gave a presentation to the TC Tourism Board.

Mr. Glancy made a comment on the letters from the two attorneys for Four Season Car Wash and Warren Harley Davidson Shop that we shouldn't be the ones to invite them to the Super Wal-Mart meetings. If Super Wal-Mart wants them there, they should invite them.

Mr. Piros gave the Fiscal Officer the Trumbull County Storm Water Management Program Annual Report for March 05 through March 06 to be filed.

109-06 Motion by Mr. Glancy, seconded by Mr. Piros to approve purchase orders.
Vote on Motion: Mr. Glancy YES and Mr. Piros YES.

YES 2
NAY 0
Motion Carried.

110-06 Motion by Mr. Piros, seconded by Mr. Glancy to approve payment of bills.
Vote on Motion: Mr. Glancy YES and Mr. Piros YES.

YES 2
NAY 0
Motion Carried.

Road Superintendent Parke:

Mr. Parke said the deadline for cemetery foundation orders will be Friday, May 5, 2006. He asked the Fiscal Officer to advertise this in the local newspaper.

MAY 01, 2006

In regard to mowing the cemetery, Mr. Glancy mentioned that if the men would take their lunch to the cemetery, it would save one hour per man.

After much discussion about the mowing of the cemetery, Mr. Piros asked Mr. Parke to assign the lowest paid man to mow full time and start right away.

A work session was scheduled with Road Superintendent, Frank Parke and the Trustees for Monday, May 15th at 8 AM at the administration building regarding mowing at the cemetery.

Mr. Hoover asked Mr. Parke about high school or college kids being hired for summer work. Mr. Parke said high school kids can't operate the tractors and can't trust them with the mowers.

Mr. Piros did a summary of the money we lost from last year's budget in the total amount of approximately \$233,000.00 due to government cuts.

Mr. Hoover questioned the money we spent on fixing the gazebo and Mr. Piros replied that we would not send the vendor his check until he returned to finish the gazebo project.

Mr. Hoover said the top priority should be the cemetery and Mr. Piros explained that City of Cortland pays us half after the cemetery funds is in the deficit, but we can't count on this money until we receive it.

Janet Perhach, 2417 Northview Drive, asked why we don't develop the new part and sell lots at a higher price. Mr. Parke explained it will take money to do this plus our township is one of the highest for gravesites.

Police Chief Sayers:

Chief Sayers reported that we received \$8,030 for the bullet proof vest settlement and we should be getting an additional \$2,500 in the near future from the Federal Government on this settlement. This money will pay for the new bullet proof vests we received from another company.

He mentioned that OPERS approved Nick Papalas' disability effective April 22, 2006. Mr. Glancy said this township will certainly miss Mr. Papalas.

Chief Sayers asked the board to approve the temporary promotion of Mike Hovis to Sergeant effective May 01, 2006 at a rate of \$20.81 plus longevity.

MAY 01, 2006

111-06 Motion by Mr. Glancy, seconded by Mr. Piros to approve the temporary promotion of Mike Hovis to Sergeant effective May 01, 2006 at a rate of \$20.81 plus longevity.

Vote on Motion: Mr. Glancy YES and Mr. Piros YES.

YES 2

NAY 0

Motion Carried.

Chief Sayers reminded everyone of Election Day tomorrow and that the township has three levies on the ballot.

Mr. Glancy asked Chief Sayers about the community festival and the reply was he is still working on it and that he will get the Brown Amusement contract to Mark Finamore today.

Chief Sayers said he will comply with the junk car regulations and will work with Mr. Mauger.

Fire Chief McKenzie:

Chief McKenzie asked the board to approve the new changes in the cost recovery prices for the Fire, Police and Road Department for the Environment Cost Recovery. They are as follows:

- A) Trumbull County Hazardous Materials Bureau Invoice Package
- B) Ohio Fire Code (2703.3.1.4) Responsibility for Clean Up
- C) Ohio Revised Code (2305.232) Hazardous Material Immunity
- D) Ohio Revised Code (3737.90) Hazardous Material Coordination
- E) Ohio Revised Code (3745.13) Environmental Emergencies Cost Recovery

112-06 Motion by Mr. Piros, seconded by Mr. Glancy to approve the new changes in the cost recovery prices for the Fire, Police and Road Department for the Environment Cost Recovery.

Vote on Motion: Mr. Glancy YES and Mr. Piros YES.

YES 2

NAY 0

Motion Carried.

Mr. Hoover asked where does the recovery money come from and Chief McKenzie replied from the insurance carrier of the vehicle who has the spill.

Chief McKenzie asked the board to approve the hiring of part-time Firefighter/Medic Patrick Dales to start May 08, 2006 pending the drug testing at an hourly rate of \$9.25.

MAY 01, 2006

113-06 Motion by Mr. Piros, seconded by Mr. Glancy to approve the hiring of part-time Firefighter/Medic Patrick Dales to start May 08, 2006 pending the drug testing at an hourly rate of \$9.25.

Vote on Motion: Mr. Glancy YES and Mr. Piros YES.

YES 2

NAY 0

Motion Carried.

Safety Committee:

Chief Sayers had nothing to report.

Zoning Inspector Mauger:

Mr. Mauger handed in his monthly report. He will contact the food vendor at Hovis Tire to come in and get a Transient Vendor's Permit. He will work with Chief McKenzie on the junk cars on Bazetta Road. Z-Tech will start on the demolition of the house on North Park Avenue and he requested one of the Trustees to accompany him to the property at 460 State Route 305. Mr. Glancy will go with Mr. Mauger and if it is determined a nuisance; it will be discussed at the next meeting.

Mr. Hoover asked if something could be done at the Schuller's property on State Route 46. Mr. Mauger to will check on this.

It was mentioned that on primary election day the administrative office would be closed.

Everyone was reminded of the three levies on the ballot.

Mr. Bates will unlock and lock the building for Election Day.

The police officer on duty will unlock and lock the administration building for meetings to be held on May 06th, 08th, 09th and 11th.

114-06 Motion by Mr. Piros, seconded by Mr. Glancy to approve the re-typed zoning manual.

Vote on Motion: Mr. Glancy YES and Mr. Piros YES.

YES 2

NAY 0

Motion Carried.

MAY 01, 2006

Chief Sayers will get prices for 3-ring binders for the zoning manual.

The price to charge per zoning manual is tabled until the next meeting.

115-06 Motion by Glancy, seconded by Mr. Piros to approve the payment of \$60 to the Trumbull County Recorder's Office to file the six new or revised pages of the new zoning manual.

Vote on Motion: Mr. Glancy YES and Mr. Piros YES.

YES 2

NAY 0

Motion Carried.

Mr. Piros reminded everyone of the Clean up Day on May 06th.

Mr. Piros reminded everyone of the mosquito spraying for May 22nd and June 26th at dusk.

There was a reminder of the Work Session/Walk-Thru with Ed Jakubick on May 17th at 8:00 AM at the police station for the future move of the administrative offices.

Cemetery foundation order deadline is Friday, May 05th.

Trumbull County Agricultural Society Press Conference will be on Thursday, May 04th at the Fairgrounds. Chief McKenzie and Chief Sayers will attend.

116-06 Motion by Mr. Glancy, seconded by Mr. Piros to authorize the Fiscal Officer to transfer within funds from 05-A-02A Cemetery (Clerical Salaries) to 05-A-12 Cemetery (Other Expenses) to pay Burrows Cemetery Mapping for the annual maintenance from May 01, 2006 to May 01, 2007.

Vote on Motion: Mr. Glancy YES and Mr. Piros YES.

YES 2

NAY 0

Motion Carried.

Mr. Bates will attend the BWC National Safety Council CEO breakfast on Wednesday, May 10th at the Holiday Inn Metroplex.

117-06 Motion by Mr. Piros, seconded by Mr. Glancy to oppose the TEL/TABOR Amendment on the November 2006 ballot. Mr. Piros asked the Fiscal Officer to mail our resolution to the Ohio Township Association.

MAY 01, 2006

Vote on Motion: Mr. Glancy YES and Mr. Piros YES.

YES 2

NAY 0

Motion Carried.

Mr. Parke stated that he received two prices for the damaged cemetery stone; one for \$400 and the other for \$600. Mr. Piros asked Mr. Parke to get with the Fiscal Officer and write a letter to the owner telling them we took the appropriate care, but apparently there was a stress fracture and the stone cracked. Ask them to contact their homeowner's insurance representative.

118-06 Motion by Mr. Piros seconded by Mr. Glancy to adjourn the meeting.

Vote on Motion: Mr. Glancy YES and Mr. Piros YES.

YES 2

NAY 0

Motion Carried.

ATTEST

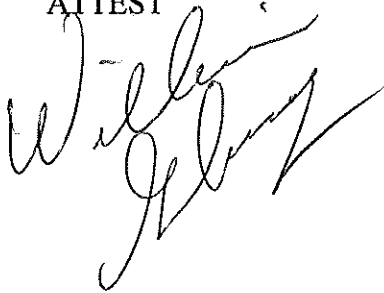

**WORK SESSION WITH TRUSTEES AND DEPARTMENT HEADS
RE-EVALUATION OF TOWNSHIP BUILDINGS
MONDAY, MAY 15, 2006 AT 6:00 PM**

Present: Bill Glancy, Mike Piros, Jeff Bates, Frank Parke, Clyde McKenzie and Mark Finamore.

Residents present were Roger Coe, Evelyn Coe and Chelsea Coe.

Clyde McKenzie stated that in January, a representative from the Aprise Group met with the department heads on the cost replacement of township buildings. Everyone had a copy of the survey and discussed the replacement cost.

Mr. Piros asked the Fiscal Officer to contact a representative from OTARMA to meet with the department heads and Trustees at a later date to get a cost to upgrade the valuation of township buildings.

**BAZETTA TOWNSHIP REGULAR MEETING MINUTES
MAY 15, 2006
7:00 PM**

Present: Bill Glancy, Mike Piros, Jeff Bates and Legal Counsel Mark Finamore

Mr. Glancy welcomed the government students from Lakeview High School.

Old business:

Mr. Bates had nothing to report.

Mr. Piros had a call from resident Art Racco, 4018 Lakeshore Drive, regarding a water problem. Mr. Bates and Mr. Piros will go to Mr. Racco's resident on Wednesday, May 17th at 9:00 AM.

Mr. Piros met with Ohio Edison representative, Janet Kitch, Dave Rockman and Mr. Parke to discuss electricity to the township park gazebo. The existing incoming electrical line is not sufficient for the load. It doesn't meet standards. Ohio Edison will give us a quote for a new transformer, 40% our cost. Mr. Piros will have more specifics at the next meeting.

Resident Evelyn Coe, 2677 McCleary Jacoby Road, asked if the park fund will pay for the transformer. Mr. Piros answered we will look at the cost when it comes in.

There was a discussion on the Baseball Academy for a baseball camp at our township park in June, which was originally turned down. Mr. Glancy talked with Jeff Rinck the day he was leaving for vacation and Mr. Glancy suggested he call Mr. Piros. Mr. Piros never received a call from Mr. Rinck and yet there were flyers left in our meeting room stating this camp was taking

MAY 15, 2006

place at our township park in June. Mr. Piros asked the Fiscal Officer to fax Mr. Finamore the letter from Mr. Rinck requesting permission to use the park and our denial letter to Mr. Rinck.

It was brought to our attention about transient vendors and Mr. Piros asked Mr. Mauger and the response was that both vendors came in and paid for a permit. Mr. Mauger asked about the gentlemen selling vegetables and flowers at the corner of Bazetta Road and State Route 305 and stated that the owner is selling these items and the property is zoned commercial. Mr. Glancy replied we cannot charge for a permit if the owner is selling on his commercial property.

Mr. Piros was contacted by Gary Newbrough, Sanitary Engineer, about the east side sewer project. He asked if Candlelite Knolls could be used for this meeting and Mr. Glancy will check into it and get back to the Fiscal Officer who in turn will notify Mr. Newbrough so mailings can go out to the homeowners from the Sanitary Engineer's Office.

Mr. Glancy met with a representative from Aqua Water about a proposed pilot project to bring water to the township. Five areas have been identified as possible locations and the project is waiting approval by the commissioners.

Pearlene Lyman, 2440 Westview Drive, asked if the water will be county or private water. Mr. Glancy responded the contractor will pay up front and county puts the lines in and takes ownership. The county charges and then they pay the contractor.

Mrs. Lyman also asked if the sewer to Stonegate will be county and Mr. Piros said both water and sewer will be county. The commissioners need to approve and then it goes to the Sanitary Engineer.

Mr. Piros had a conversation with Mr. Mahoney from the Conservation Club who had concerns with homeowners who have property adjacent to the club's property that they are using and building on the club's property. Mr. Mahoney had the property surveyed and these documents were turned over to Mr. Mauger to inspect.

Mr. Mauger stated when they sign the zoning permit with the information on their property lines, we can't determine if they are true. Mr. Glancy suggested that to prevent any future problems, Mr. Mauger should inspect them before they are actually built.

Mr. Glancy asked Mr. Mauger about the three trailers on Bazetta Road that are tied into one septic tank. The neighbors are complaining and when Mr. Glancy brings this complaint before a Trustee meeting, Mr. Glancy is accused of picking on that particular neighbor.

Fred Boughner, 3190 Morrow Drive, read a letter he received from the Board of Health telling him he has 60 days to do a band-aid fix on his septic system and the 60 days is up on Tuesday,

MAY 15, 2006

May 23rd. He wanted to know when the June meeting will be so he can inform the Board of Health because they say the Sanitary Engineer's office says they are going to have a specific meeting and then nothing happens.

Mr. Finamore replied there is some conflict between the Health Department and the Sanitary Engineer's Office. The EPA is getting after the health department and the sanitary engineer's office is behind in getting these put in place, years are stretched.

Mr. Piros responded to the east side sewer project. The commissioners have okayed \$300,000 for this feasibility study and it is done. The June meeting will let the east side residents find out about their assessment figures which can be paid up front or accessed on their taxes. If the residents vote yes to go ahead, the target date should be the end of 2006.

Fred Hoover, 2282 State Route 305, said the residents might see a higher price tag on sewers and some may not be able to afford them.

Carol Braden, 2126 Wilmar Drive, had a concern about the mowing at the cemetery. Our cemeteries are historical. Mr. Glancy said he was in the cemetery yesterday and it was mowed, trimmed and looked good. The weather hasn't cooperated either. Mr. Parke said his crew mowed in the rain yesterday.

Pearlene Lyman, 2440 Westview Drive, said the county engineer's office said our township roads and our road superintendent are the best in the area. Mr. Glancy said we have always said that.

Mrs. Lyman said she took water and sewer petitions from residents on Westview Drive to the sanitary engineer's office and wanted to know why it takes so long. She had 92% of the residents who signed the petition said they want both water and sewer.

Mr. Finamore explained the long process including the drawings to the financing of the project.

Mr. Piros said the county has to follow guide and time lines.

119-06 Motion by Mr. Piros, seconded by Mr. Bates to approve the minutes of the May 01st meeting.

Vote on Motion: Mr. Bates YES, Mr. Glancy YES and Mr. Piros YES.

YES 3

NAY 0

Motion Carried.

MAY 15, 2006

The following correspondence was read:

1. Emailed information to newspaper for the Work Session /Walk Thru for Wednesday, May 17th at the police station at 8:00 AM on relocating the administrative offices.
2. Emailed information from last meeting to the Tribune, Cortland News and the Review.
3. Received resolution granting annexation of Russell Lauer's property.
4. Fax received from Dr. Chris Kundala, Director of South Africa Department of Minerals and Energy regarding overdue payment bills totaling \$14 million, our portion for our help would be 30% of the \$14 million.
5. Received a letter from Aqua of Ohio asking if we are interested in pursuing water service and if so, to contact Al Sauline.
6. Received a letter from Dominion informing us of the regulations for natural gas transmission pipelines.
7. Received a pamphlet from TIP Talk Update from Eastgate Regional Council informing us of the transportation improvement program update for 2006.
8. Sent out letters to state and federal representatives about our opposition to COPE National Cable Franchise Act (COPE – Communications, Opportunity, Promotion and Enhancement).
9. Advertised for mosquito spraying on May 22nd at dusk and work session with Road Superintendent Parke at 8:00 AM on Monday, May 15th to discuss cemetery mowing.
10. Sent resolution proclaiming opposition to the TEL or TABOR Amendment, which will be placed on the November 2006 ballot to the Ohio Township Association in Columbus.

120-06 Motion by Mr. Bates, seconded by Mr. Piros to approve purchase orders.

Vote on Motion: Mr. Bates YES, Mr. Glancy YES and Mr. Piros YES.

YES 3

NAY 0

Motion Carried.

121-06 Motion by Mr. Piros, seconded by Mr. Bates to approve payment of bills.

Vote on Motion: Mr. Bates YES, Mr. Glancy YES and Mr. Piros YES.

MAY 15, 2006

YES 3

NAY 0

Motion Carried.

Police Chief Sayers:

Police Chief Sayers mentioned there was a DUI check point here at the township hall on Friday, May 12th from 6:00 – 10:00 PM. Two more have been scheduled in the township. He also submitted his monthly report for April.

Chief Sayers requested authorization to purchase two lap lots from Dell at the cost of \$1,614.20 including shipping to be split between funds 09-A-04C, 09-A-14J and 22-A-01.

122-06 Motion by Mr. Bates, seconded by Mr. Piros to approve the purchase of two lap tops from Dell for the police department at the cost of \$1,614.20 including shipping to be split between funds 09-A-04C, 09-A-14J and 22-A-01.

Vote on Motion: Mr. Bates YES, Mr. Glancy YES and Mr. Piros YES.

YES 3

NAY 0

Motion Carried.

Chief Sayers requested authorization to enter into a contract with the Trumbull County Fair for a booth at the 2006 fair at a cost of \$270 to come out of fund 09-A-10. Mr. Glancy asked if it was worth while for us to be there and who will work the booth. Chief Sayers stated he will use part time officers and the township will not be sacrificed with our being at the fair. He said they gave away about 1,000 gun locks and did about 500 fingerprinting at the 2005 fair. Janet Perhach, 2417 Northview Drive, said she volunteered there last year and felt it was very worthwhile.

123-06 Motion by Mr. Piros, seconded by Mr. Glancy to approve the spending of \$270 for a booth at the Trumbull County Fair as long as it doesn't take away from the township priorities and responsibilities.

Vote on Motion: Mr. Bates YES, Mr. Glancy YES and Mr. Piros YES.

YES 3

NAY 0

Motion Carried.

Chief Sayers assured the Trustees that the residents will not be sacrificed and they will be safe.

MAY 15, 2006

Chief Sayers asked about the festival at the park and Mr. Finamore is still looking into the contract with Brown Amusement. This will be tabled until the next meeting.

Mr. Glancy asked Chief Sayers who is filling in for Sergeant Nick Papalas who retired on disability April 22nd and Chief Sayers replied we are filling those hours created by the temporary promotion of Mike Hovis with part-time officers. His budget wouldn't permit full-time officers.

Fire Chief McKenzie:

Chief McKenzie submitted his April report and thanked the residents for their recent support of the fire renewal levy. He said there will be another renewal that needs to be placed on the ballot for next year. He stated again this year we will have two local student drawings from Bazetta Elementary School on the State Fire Marshal's calendar for 2007. He has notified the principal as well as the families. One student is in the first grade and the other student is in the second grade. There will be a ceremony sometime during Fire Prevention Month in October.

Mr. Bates asked Chief McKenzie to contact C.A.P.E. about a retraining/refreshers course for all township employees for our drug free workplace.

Road Superintendent Parke:

Mr. Parke said he met with Mr. Piros, Mr. Rockman and Mr. Governor on the handicap ramp at the gazebo which was put in by Calhoun Concrete. It doesn't have a footer and does not meet the specifications. There will be a meeting with the contractor in the near future.

His department will start tile jobs plus roadside mowing and will continue cutting the grass at the cemeteries.

Mr. Glancy asked if Mr. Parke would look into the hole at the entrance to Prince Drive. Mr. Parke will get in touch with the county.

Zoning Inspector Mauger:

Mr. Mauger said he has talked with Mr. Finamore on the property at 3054 North Park and has given all the additional necessary papers required by the Trumbull County Building Inspector to Gary Zuga who will demolish the house. Mr. Finamore stated that this additional \$50 permit is required for the contractor to take the debris to a registered licensed landfill. This is in conjunction with all utility companies.

Mr. Mauger stated he and Chief Sayers went to the property on Bazetta Road to look at the junk cars there. Chief Sayers told Mr. Mauger that they didn't fall within the codes for him to enforce

MAY 15, 2006

the property owner to do away with the junk cars. Pictures were submitted to the Trustees. Mr. Glancy asked if they tried to start them, and the response was no.

At this time, Mr. Finamore stated there are four ways to get rid of junk cars.

1. Township Zoning Resolution
2. State Motor Vehicle Regulations
3. Nuisance Abatement
4. Township Regulation of Junk Motor Vehicles Storage.

(See attachment)

Safety Committee:

Chief Sayers had nothing to report.

Park Board:

Jack Governor said he did not put up two sets of bleachers because they are not safe.

Administration:

There was a reminder of mosquito spraying on Monday, May 22nd and Monday, June 26th.

There was also a reminder of the Work Session/Walk-Thru on Wednesday, May 17th at 8:00 AM at the police station with Ed Jakubick on the proposed relocation of the administrative office to the police department.

Mrs. Braden asked why the offices being moved and Mr. Piros replied we will get free gas, plus share electrical, telephone, insurance and secretarial services. We plan to sell or lease this building to offset the cost of the expansion. We only need to expand the meeting room.

124-06 Motion by Mr. Glancy, seconded by Mr. Bates to increase the price of the new zoning manual to \$10 effective May 15, 2006.

Vote on Motion: Mr. Bates YES, Mr. Glancy YES and Mr. Piros YES.

YES 3

NAY 0

Motion Carried.

MAY 15, 2006

125-06 Motion by Mr. Bates, seconded by Mr. Piros to increase the original bid from Z-Tech to include the additional \$50 permit needed to do the demolition on 3054 North Park Avenue.
Vote on Motion: Mr. Bates YES, Mr. Glancy YES and Mr. Piros YES.

YES 3
NAY 0
Motion Carried.

Timber Creek Heights Street Lighting quote from Ohio Edison was revised due to the time restraint on the original quote. A meeting will be held on Monday, June 19th at 6:00 PM for all Timber Creek Heights residents. Mr. Piros will send out letters to residents as well as Ohio Edison representative, Genesis Electric Corporation, the contractor, and the auditor's office. Mr. Finamore will be present to answer any legal questions.

126-06 Motion by Glancy, seconded by Mr. Piros to approve the purchase of 12 5X8 Nylon US Flags to be taken out of the general fund.
Vote on Motion: Mr. Bates YES, Mr. Glancy YES and Mr. Piros YES.

YES 3
NAY 0
Motion Carried.

Tom Shortreed addressed the Trustees concerning the easement with the township and the Eaton Group Building located next door. Mr. Shortreed plans to operate a financial services business. Mr. Finamore will take care of this matter.

127-06 Motion by Mr. Piros, seconded by Mr. Bates to authorize the Fiscal Officer to transfer monies within a fund from 05-A-02 Cemetery (Salaries-Burials) to 05-A-01 Cemetery (Salaries-Mowing) in the amount of \$4,520.55
Vote on Motion: Mr. Bates YES, Mr. Glancy YES and Mr. Piros YES.

YES 3
NAY 0
Motion Carried.

128-06 Motion by Mr. Bates, seconded by Mr. Glancy to adjourn the meeting at 8:45 PM.
Vote on Motion: Mr. Bates YES, Mr. Glancy YES and Mr. Piros YES.

YES 3
NAY 0
Motion Carried. ATTEST



TIRED OF THOSE JUNK CARS?

By: Mark S. Finamore, Township Legal Counsel

One of the most frequently asked questions I receive as township legal counsel is "how do we get rid of junk motor vehicles?" and what is the "fastest and cheapest way to get rid of them?"

Well, you may be surprised, but this is one problem that the state legislature has given townships a lot of effective options and they do work if you are willing to take action.

Under current state statutes, the state legislature has provided four separate means to either prohibit, regulate or provide for the removal of junk motor vehicles in the township. The four legal means of dealing with junk motor vehicles available to townships are:

1. Township Zoning Regulation

The township can adopt a zoning resolution prohibiting the storage of unlicensed and/or inoperable junk motor vehicles and automobile parts in the township. Enforcement of the violation of the zoning resolution requires the following procedures: (i) the filing of a minor misdemeanor zoning complaint in the municipal court or county court in the jurisdiction of the township which would provide for up to a \$500.00 a day fine for each and every day of violation of the zoning resolution; (ii) the filing of an injunction pursuant to Section 519.24ORC in the Court of Common Pleas, which if not complied with would subject the property owner sanctions from the court by way of fine and/or jail sentence.

2. Section 4513.65 ORC State Motor Vehicle Regulations

Section 4513.65 ORC authorizes the township board of trustees to send a certified mail notice, to the person having the ownership or right of possession of the property on which a junk motor vehicle is stored, requiring the junk motor vehicle to be covered by

being housed in a garage or other suitable enclosure or removing the vehicle from the property.

Failure to comply with the notice and for each subsequent period of 30 days the junk motor vehicle continues to be left constitutes a separate offense under Section 4513.65. A violation of Section 4513.65 is a minor misdemeanor on a first offense, punishable by a fine of up to \$100.00 only; and on a second offense is classified as a misdemeanor of the fourth degree, punishable by up to a \$250.00 fine and/or 30-day jail sentence; and on a subsequent offense is a misdemeanor of the third degree, punishable by up to a \$500.00 fine and/or a 90-day jail sentence. However, in order to meet the criteria for a junk motor vehicle under the statute, the motor vehicle has to meet all of the following requirements: (a) three years old or older; (b) extensively damaged, said damage including but not limited to any of the following: missing wheels, tires, motor or transmission; (c) apparently inoperable; and (d) having a fair market value of \$1,500.00 or less. The problem with using this statute to remove junk motor vehicles from property is that the threshold value of the automobile in the \$1,500.00 or less range would exclude a lot of automobiles which, although having a higher value, would still be considered junk motor vehicles in appearance to most individuals, and although unsightly, would not be prohibited under this statute.

3. Section 505.87 ORC Nuisance Abatement

Section 505.87 ORC provides the township with the authority to provide for the abatement, control or removal of vegetation, garbage, refuse and other debris from land in the township if the

Continued on page 33

JUNK CARS

Continued from page 31

board determines that the owner's maintenance of such vegetation, garbage, refuse and other debris constitutes a nuisance. In order to invoke this statute, the township must use the following procedure: (i) The township zoning inspector or other township official must make an inspection of the property and take pictures of the junk automobiles to be removed. (ii) The township zoning inspector must then appear at a township regular meeting or special meeting held for the purpose of addressing the junk motor vehicles and provide the township with a written inspection report along with the pictures and recommend to the township board of trustees to declare the property a nuisance. (iii) If the township trustees concur that the junk motor vehicles constitute a nuisance, they must pass a resolution declaring the property a nuisance and ordering the abatement and removal of the junk motor vehicles.. (iv) The zoning inspector would then do a record search at the County Auditor's office and/or County Recorder's office to determine the legal owner of the premises and/or any other lien holder and serve them a written notice that unless the property owner removes or abates the junk motor vehicles within 7 days of the notice, the township would enter upon the property, provide for the removal of the junk motor vehicles, and the cost of doing so would be placed as a tax lien on the property to be collected by the County Auditor and returned to the general fund of the township treasury. This written notice must be served in one of the following ways: (i) If the owner is a resident of the township or is a nonresident whose address is known, the township will send notice by certified mail, return receipt requested. (ii) If the owner is a resident of the township or is a nonresident whose address is known, the board may give notice to the owner by causing any of its agents or employees to post the notice

MANY TOWNSHIP COMPANIES, JUNKYARDS AND SALVAGE YARDS ARE WILLING TO PROVIDE THE REMOVAL SERVICES FREE OF CHARGE FOR THE RIGHT TO OBTAIN AN ABANDONED CERTIFICATE OF TITLE TO THE VEHICLES.

on the principal structure on the land and to photograph the posted notice with a camera capable of recording the date of the photograph on it. (iii) If the owner's address is unknown and cannot be reasonably obtained, it is sufficient to publish the notice once in a newspaper of general circulation in the township.

If within 7 days after notice is given, the owner of the land fails to remove the junk motor vehicles, the board of trustees can then provide for the removal by employing the necessary labor, materials and equipment to perform the task, and the expenses incurred by the township shall be certified to the County Auditor for collection with other property taxes and returned to the general fund of the township.

* The Ohio Attorney General in Opinion 90-020 has determined that junk automobiles may be included as "refuse" or "other" debris for purposes of 505.87 ORC.

4. Section 505.173 ORC Township Regulation of Junk Motor Vehicle Storage

Section 505.173 ORC authorizes township trustees by resolution to regulate the storage of junk motor vehicles on private property, a violation of which would constitute a minor misdemeanor punishable by up to a \$100.00 a day fine. Under this section of the law, a junk motor vehicle is defined as a motor vehicle which is (a) 3 model years old or older; (b) apparently inoperable; and (c) extensively damaged, including but not limited to any of the following: missing wheels, tires, engine or transmission. As you can see, the definition of a junk

motor vehicle under this section is far more liberal than the definition of a junk motor vehicle contained in Section 4513.65 ORC and therefore would entitle you to provide for prohibition of unsightly vehicles which under the other statute would not meet the \$1,500.00 or less qualification. However, this statute does not authorize the township to take action on its own to cause the removal of the motor vehicles and to tax the property owner for the cost if the property owner does not remove the motor vehicles to avoid the payment of fines. That is, under this statute the only penalty that can be imposed is a fine for the violation and not an order to remove the motor vehicles.

In my experience with these provisions of the law, it is my opinion and advice that the most effective manner to eliminate the storage of junk motor vehicles on properties is by the township nuisance abatement authority under 505.87 ORC. It is by far the fastest way to eliminate junk motor vehicles without the necessity of going through a court proceeding. Also in my experiences, I have found that many towing companies, junkyards and salvage yards are willing to provide the removal service free of charge for the right to obtain an abandoned certificate of title to the vehicles so that they keep or sell them for the salvage value.

Now, get rid of those junk cars. ☺

**WORK SESSION WITH FISCAL OFFICER AND TRUSTEES
MONDAY, JUNE 05, 2006 AT 8:00 AM**

Present: Bill Glancy, Mike Piros, Jeff Bates, and Martha Urchek.

Martha handed out to the Trustees the following reports: Appropriation Status Report dated June 01, 2006, along with the tax rate from the Trumbull County Auditor listing the amount of revenue that will be generated due to the passing of the two levies in November of 2005 and the three levies in May of 2006, the Township Amended Certificate of Estimated Resources dated January 27, 2006 showing each department's fund budget for 2006, the Valuation and Resources dated January 2006 showing the estimated tax revenues for 2006 and Receipt Account Status Report dated June 01, 2006 showing all the up-to-date receipts posted, and the Cash Journal dated June 01, 2006 showing the balance in our checking and investment accounts.

Martha explained we are doing okay, but will continue to watch the monies coming in and going out.

**BAZETTA TOWNSHIP REGULAR MEETING
MONDAY, JUNE 05, 2006 AT 9:00 AM**

Present: Bill Glancy, Mike Piros, and Jeff Bates.

Mr. Glancy opened the meeting by stating we are going to vary from the agenda due to one of the Trustees needing to leave for work.

Mr. Glancy commented on the last meeting's minutes saying not everything is recorded in the minutes. He apologized that maybe we go too fast and that Martha needs to tell us to slow down so every word goes in the minutes. He suggested the board should consider a tape recorder. Mr. Piros said he has no problem with a tape recorder, but you have to watch what you say. Mr. Bates has no problem with a tape recorder.

Mr. Parke asked if we can use the one that is used for zoning meetings and Mr. Piros said we could. We will have to keep the tapes in the safe.

129-06 Motion by Mr. Piros, seconded by Mr. Glancy to approve the minutes of the May 15th meeting.

Vote on Motion: Mr. Bates YES, Mr. Glancy YES and Mr. Piros YES.

YES 3

NAY 0

Motion Carried.

JUNE 05, 2006

It was rumored that the State Park had a grant and was planning to blacktop the driveway. Mr. Glancy asked Mr. Parke to call Rocco Greco at the State Park.

Pearlene Lyman, 2440 Westview Drive, asked how can they get a grant and we don't know about grants. Mr. Piros said you have to request grants.

Mr. Parke will attempt to fill the holes again at the park.

Mr. Glancy asked about the roadside mowing and Mr. Parke replied that the mechanic is working on the road ground mower. Mr. Bates asked why this wasn't done over the winter months. Mr. Parke replied because we use the tractor for different jobs such as working in the park which requires different attachments.

Mr. Parke said he will be doing the mowing and it will take about a week mowing the bottom of the ditch to the edge of the road and he will begin mowing this week, probably Thursday.

Mr. Bates left the meeting at 9:45 AM.

Mr. Parke stated he received a call and then a fax from a Danny Armstrong, 3835 Durst Clagg Road, about a letter he received from the board on May 15, 2006 stating the effluent must be discharged into a tiled ditch. If an open ditch exists, it must be tiled at the property owner's expense and in accordance with township ditching requirements. His ditch is not tiled. Mr. Armstrong wants to know if we dig and install the pipe and if we backfill the ditch after the tile is put in. Mr. Parke says he has never done this before. The form dated May 15th has a clause #5 added. Mr. Glancy suggested Mr. Parke to contact out legal counsel, as he is the one who put the new #5 clause in the letter in 2004. Mr. Parke will inform the Trustees what he finds out from Mr. Finamore.

Old Business:

Mr. Piros said that according to the union contract, work sessions are scheduled periodically. A work session with the Firefighters Local 3703 will be at the township hall on Monday, June 26, 2006 at 8:00 AM. Mr. Piros asked Martha to send a letter to Mike Mannella, President of Local 3703, along with the same letter to union members Tom Rink and Mike White informing them of this meeting and also to advertise in the newspaper.

Earlier today, Mr. Jakubick of Jakubick-Sexton Architects met with the Trustees to discuss the architectural design and fee proposal for the addition to the existing police station encompassing the township administrative functions. With the uncertainty of General Motors and Delphi, and delinquent taxes could affect the budget, the board decided to table this at the present time.

JUNE 05, 2006

Mr. Piros received a letter from the Trumbull Soil and Water Conservation District dated May 18, 2006 addressed to Mr. Larry Robinson of Broad Meadows Estates stating all work is to stop due to monies not being received in the amount of \$1,297 from January 2005 for fees and outstanding balances along with the submittal of the application. Mr. Piros asked Martha to copy this letter to Mr. Mauger, our Zoning Inspector and Police Chief Sayers to watch this property so no activity goes on there.

Evelyn Coe, 2677 McCleary Jacoby Road, asked about the gas well road by the Conservation League on McCleary Jacoby Road as to what they are dumping on the open field. Mr. Piros said that was ceased long ago. She saw them three days ago.

Mr. Glancy said it is grease from restaurants being dumped in the open field and it is legal. He has talked with the Health Department on this. Mr. Lawson of Warren Sanitary Company, who owns the property, is dumping the grease.

Mrs. Coe asked how many acres and Chief Sayers thought it was between 80 and 100 acres. Mr. Glancy said the EPA has been involved and the Trustees as well as Mr. Parke have been there a dozen times. Chief Sayers said this has been going on for 20 years.

Mr. Glancy said they used to dump brine on the fairgrounds, but that isn't allowed anymore.

Mr. Parke said he met with Calhoun Concrete and Mr. Rockman, Architectural Services and Mr. Tom Gladd of the Trumbull County Building Department and the handicap ramp has been approved. Mr. Piros suggested that Mr. Parke take the signs and the roping down and have Jack Governor pressure wash the gazebo.

Mr. Piros mentioned he received his invitation to the Trumbull Township Association Lamb and Chicken Roast on June 15th in Vienna Township's Four Seasons Trailer Park. He asked everyone to make sure they turn in their reservation to Martha as soon as possible.

Mr. Glancy mentioned the BWC Drug Free Work Place mandatory refresher training for all full-time and part-time employees is scheduled for June at the police station. Please turn in your day and time to Martha as soon as possible.

Mr. Glancy said he received a complaint about high grass at 2126 Wilmar Drive and Mr. Piros will contact the property owner since this is in his neighborhood.

Mr. Piros mentioned he had met with Janet Kitch of First Energy on the transformer for the township park. The cost of the 25 KVA Transformer on a pole is \$1,710.41. The township would be required to pay 40% or \$684.16 before construction. An additional ½% of the total cost of construction (\$8.55) would be added to the new meter's electric bill each month through

JUNE 05, 2006

December of 2007. Additional costs would be a new pole, a new box plus labor to put the pole in. Mr. Parke said he could contact Brent Westbay to drill the hole for the pole. This is not a simple task. After the engineering study, there are permits and then it would go out to bid.

Evelyn Coe, 2477 McCleary Jacoby Road, asked where the money would come from and Mr. Piros said it would come from the Park's upgrade fund.

Pearlene Lyman, 2440 Westview Drive, asked about the work stoppage on Robinson's Broad Meadows and if there is also a stoppage on Stonegate. Mr. Glancy said no and the reason there hasn't been any activity is because of the rain. She stated she contacted Gary Newbrough about the Westview Sewer Project and Mr. Newbrough told her it was in the design stage for the summer of 2007.

Mr. Piros attended a meeting on Lakeshore and Westlake Sewer and Water Project with the Commissioners to weeks ago and the Westview project was discussed and is in the engineering stage. The East side project which is the biggest is in the design stage. Mr. Piros will call Mr. Newbrough and get back to Mrs. Lyman.

Mr. Piros said there is a meeting for the East side sewer project involving sections of Route 5, 305, and 46 along with Williams, Morrow, parts of McCleary Jacoby, Wilmar, Circle and Northview on Tuesday, June 20th at Candlelite Knolls on Bazetta Road at 7:00 PM. There will be representatives from the commissioner's office, Sanitary Engineer, EPA, Board of Health as well as the auditor's office. This is one project and if the residents say yes, it will go out for bids and should begin in September of 2006. The auditor's office will be able to explain how it can be assessed on property owner's taxes.

Mr. Klamut, 2800 Niles-Cortland Road, wanted to know how much of Route 46 is involved. Mr. Piros said it will go down Route 46 involving three or four houses and Mr. Richard Musick of 3283 Niles-Cortland Road will pay for his own.

The West side consisting of Lakeshore and Westlake Drives will have a meeting in July of 2006.

Mr. Klamut, 2800 Niles-Cortland Road, asked how he can get water and sewer and Mr. Piros said there are petitions here that need to be signed by all residents in your area who are interested in water and sewer and there needs to be 80%. These petitions are then taken to the Sanitary Engineer's Office. Mr. Piros said you aren't committed until the final stages.

Mr. Piros shared some new regulations from the State of Ohio that go into effect July 01st of this year. A new septic system now would cost approximately \$12 - 15,000, after July 01st, a new septic system would cost approximately \$20 - 25,000 with a yearly update. Mr. Piros was interrupted by Mr. Glancy, but Mr. Glancy let Mr. Piros continue as Mr. Glancy said "you are

JUNE 05, 2006

cheaper than Mark Finamore.”

Residents are asking about grants and Mr. Piros said that would be explained at the June 20th meeting.

Bud Bowen, 2452 State Route 5, asked about the Sidley sewer project.

Mr. Piros said that particular property on State Route #5 was being considered for purchase by Kundle Industries if sewer could be obtained. The property would have to be rezoned Industrial as it is zoned Commercial and since Kundle Industries had to purchase the property to do this and Kundle needed to move quickly, they lost interest. Since they didn't purchase the property, one can get a grant for anticipating to purchase.

Mr. Piros said then another prospect was a car dealer and Mr. Glancy said it was a Chevrolet dealer and they didn't need sewers. Mr. Glancy said there hasn't been anything further on that piece of property.

Mr. Glancy said there is money lying out there. Look at sewers to Braceville.

Mr. Bowen mentioned the Golden Triangle and said some of the businesses near him would like to see sewer come down Route 5.

Mrs. Lyman wanted to know about the hold-off on septic tanks by the health department.

Mr. Piros said the East side project has a band-aid fix as well as the Lakeshore project. The health department indicates they are in the works, engineering, first of the year. Anything after that, who knows. Mr. Piros suggested Mrs. Lyman call the health department to get more information.

Mr. Piros said the health department doesn't know what they are doing.

Mr. Glancy mentioned he received a call about garbage on Perkins-Jones Road and for Mr. Mauger's benefit, I didn't get shot at. He talked with the tenant as well as the landlady and as of yesterday, Sunday, the garbage was gone.

Mr. Glancy mentioned that State Transportation District #4 is closing Route 46 between 5 and 87 starting on June 05th and ending on July 31st. The length of the detour is 12 miles. The detour route is Route 5 to Route 11 to Route 87. They will be replacing a culvert.

Mr. Glancy read portion of the Grassroots newsletter from the Ohio Township Association on the TEL (Tax Expenditure Limitation) proposal. It has been rejected and they are trying to get if off

JUNE 05, 2006

the November ballot.

Mr. Glancy said this board will be cracking down on junk cars and neglected buildings to improve our townships appearance and increase property values. Attorney Finamore is working closely with the Trustees on a resolution to effectively deal with these issues.

Mr. Klamut asked if there are any regulations on newspapers being thrown in resident's yards. He stated they are placed in the Tribune or Vindicator boxes and then the Tribune and Vindicator newspaper carriers take them out of the boxes and throw them on the ground. These then are blown in yards or ditches. There are so many blue bags lying on the ground in this township. Mr. Glancy said he is aware of this and there is nothing the township can do at this time.

Evelyn Coe questioned the Impact Baseball Academy Camp at the park in June. Mr. Glancy said this organization met all the criteria requirements. She asked if it will interfere with the LAC games and practices and Mr. Glancy said no as they are having the camp from 8:00 AM to noon June 12th through the 15th.

Evelyn Coe questioned Chief Sayers about who is shooting behind the Conservation League as a bullet came in her backyard. Chief Sayers will look into this.

Fire Chief McKenzie:

Chief McKenzie stated he received our Commercial Equipment Direct Assistance Program award letter telling us we will receive an AMKUS Rescue Tools, Gas Operated System. This is free with no grant fund matching fee. Once received, he will notify the Trustees.

Mr. Glancy complimented Captain Dennis Lewis on a job well done. He is the best grant writer.

Roger Coe, 2677 McCleary Jacoby Road, asked Chief McKenzie about demonstrations of this new tool and Chief McKenzie said he is planning a demonstration for the public to view.

Evelyn Coe, going back to the Impact Baseball Academy Camp asked if there would be any money returned to us from this camp. Mr. Glancy said they are non-profit. Nothing to us just like the Lakeview Athletic Club, they charge the kids for registration and give them some equipment and we receive no money from them. She asked if this camp was for Cortland kids only and Mr. Glancy said it is for all kids just like the Valley Extreme Baseball Club doesn't consist of just Cortland girls.

Police Chief Sayers:

Chief Sayers turned in his monthly report for May.

JUNE 05, 2006

He stated he and the Corp of Army Engineers have a contract again this year to work together with the State park Rangers in policing around the lake.

The speed trailer is on Bazetta Road and he will move it to Durst Clagg later this week.

Everything has been set for a booth at the Trumbull County Fair from July 09th through July 16th.

Fireworks at the lake by Grant Oakes will be Monday night, July 03rd, one day earlier than last year.

Joe Sofchek attended the Mahoning Valley Safety Council last week in place of Chief Sayers.

The emergency exercise conducted at the airbase on April 14th was successful with the county passing with 13 objectives.

Also, he reported that the township met the 2006 requirements for the BWC, which makes us eligible for a 4% rebate later this year in October.

Mr. Klamut asked Chief Sayers and Mr. Parke if theft had been done at the cemeteries. He stated the Veterans placed over 1,600 flags at All Souls Cemetery to find that quite a few aluminum and bronze sticks had been stolen. Mr. Park said some had been stolen from our cemeteries. Mr. Glancy asked if a police report was made out and he said no, he thought it was better to get it low profile. Mr. Glancy further stated that keeping it quiet doesn't solve the problem

Safety Committee:

Chief Sayers said the quarterly Safety Committee Meeting will be on Tuesday, June 06th at 9:00 AM at the police station. Evelyn Coe asked what this committee was for and Chief Sayers explained its purpose.

Road Superintendent Parke:

Mr. Parke turned in his monthly report.

He also mentioned the department truck got a flat tire after crossing the railroad crossing on Route 305. Mr. Glancy said the railroad crossing on Bazetta Road is just as bad. Mr. Parke asked Chief McKenzie if any of his vehicles had any damage and the reply was no, but agreed the crossings are bad.

JUNE 02, 2006

Martha said she called Norfolk Southern Railway Company in April after a resident sent a letter to us complaining about it. At that time, Mr. Parke gave Martha the phone number as well as the crossing ID number.

Mr. Piros asked Martha for the name of the person she talked to in April and the company's address and he will draft a letter to them.

The following correspondence was read by Martha:

1. Drug Free Workplace Conference on June 07th sponsored by Neil Kennedy Recovery Clinic. (Copy given to Jeff Bates)
2. Professional Risk Management (Our TPA) is sponsoring a Worker's Compensation/Safety Information and Health Care Update Seminar on Tuesday, June 20th at 8:00 AM to noon in Youngstown. (Copy given to Jeff Bates)
3. Information was sent to our Legal Counsel on the sewer easement for Neal Eaton's property which Tom Shortreed has recently purchased.
4. Received a letter from Governor Taft inviting us to participate in the Ohio Business Mission to Mexico October 8-14, 2006. Primary goal for this to open new doors and strengthens existing business relationships with Mexico buyers and encourage Mexican owned firms to consider investing in Ohio.
5. Received a letter from Safety Communication Solutions for a seminar on June 13th in Sebring, Ohio for a pipeline damage prevention training program. (Copy given to Trustees)
6. Delta Dental sent a letter informing us of the increasing number of dental claims outside of the United States. They are taking extra steps to validate all foreign claims.
7. Sent statement to all concerned of votes cost for the three levies that passed in May, 2006.
8. Received a letter from David DeChristofaro wanting to assist us in our water and sewer projects. (Copy given to Trustees)
9. Grassroots Clippings for June, 2006. (Copy given to Trustees)
10. Emailed our meeting minutes to the newspapers.
11. Letters were mailed to Timber Creek Heights residents on the street lighting project.

JUNE 05, 2006

12. Mosquito Lake Meeting held on May 31st at 9:00 AM in Mr. Letson's office.
13. Contacted our insurance carrier asking if we were covered regarding broken stone at the cemetery for the Sparhawk family.
14. Sent revised information to Darlene St. George on the regional Fire and EMS Service Consolidation.
15. Received invitation for the 2006 Cortland Street Fair Parade on June 24th.
16. Received Trumbull County Board of Health Meeting Agenda for May 17th meeting and meeting minutes for April 19th meeting.
17. Received informational sheets for Rabies. (Copy given to department heads)
18. Received letter from Trumbull County Commissioners on water petition for Westview Drive.
19. Received letter from Trumbull County Health Department on a meeting on the Lakeshore Drive sewer project.
20. Received award letter from Commercial Equipment Direct Assistance Program. (Forwarded to Captain Dennis Lewis)
21. Received several emails and letters on the TEL Plan, which will be removed from the November ballot.
22. Received update on the 2005 Annual Drinking Water Quality Report from the City of Warren.
23. Received status report of all current Trumbull County Sanitary Sewer Projects.
24. Sent letters to MKC Associates and BIE Associates for their bids that were sent in for professional design services for the addition to the police station. Jakubick & Sexton Associates were awarded the bid.
25. OTA Summer Convention in Dayton Wednesday, August 02nd through Saturday, August 05th.
26. Received invitation from the Trumbull County Health Department for an open house at their newly renovated offices.

JUNE 05, 2006

27. Received letter from Trumbull County Commissioners granting annexation and of specific findings of fact in the matter of annexation of 1.0292 acres of land from Bazetta Township to the City of Cortland. (Russell Lauer's property)
28. Copy of a letter from Attorney Finamore to Michael Ratliff, 3034 North Park Avenue, informing them they can live in a mobile camper on this property for 40 days from date of letter, June 01, 2006.

140-06 Motion by Mr. Piros, seconded by Mr. Glancy to adjourn the meeting.
Vote on Motion: Mr. Piros YES and Mr. Glancy YES.

YES 2

NAY 0

Motion Carried.

By Motion Adjourned.

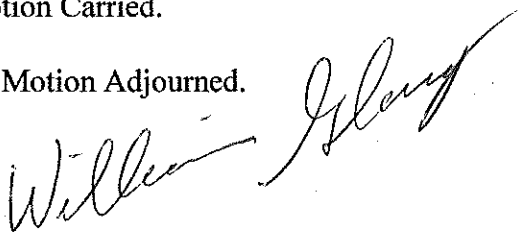
A handwritten signature in cursive script, appearing to read "William Glancy", is written over the text "By Motion Adjourned.".



BAZETTA TREE, INC.

P.O. Box 189
Cortland, Ohio 44410

Phone (330) 638-6208 (Warren)
or
(330) 726-9994 (Youngstown)
Fax (330) 726-3277



W/AVIK. / BY RD
CUSTOMER NAME: BAZETTA TWP.
STREET: 3372 - SR 5
CITY/STATE/ZIP: CORT. 44410

FRANK (442-7133)
DATE: 5/19/04
DIRECTIONS TO JOB: H/ OFF SR 46, TO EAST - BETWEEN TAMER WIN GOLF COURSE AND ASH HILLS GOLF COURSE
PHONE: (330) 726-4517

ITEM	DESCRIPTION	
1	(A+ 2427 NORTHVIEW DR) (1) LARGE SILVER MAPLE (FRONT - LT. OFF DRIVE, BY ROAD) REMOVE (1) LARGE LOW CUT LIMB ON FRONT, OVER ROAD OFF TO MAIN TRUNK (RIBBON UNIT) (NOTE - MUST CALL AND GET GARDEN FIELD OPENED 1ST)	175.00
2	(1) SMALL PART-DEAD WILD CHERRY (TURT. BEARD BESIDE BACK OF IMAG. STA. PLAY AREA - RIBBON UNIT) REMOVE	SR 375 TWP TO AT (ACROSS FROM LINES) SR 300
3	(1) LARGE TRIPLE LEAF, FACT-DEAD WILD CHERRY (BEHIND 1st FIELD ON SIDE BURN - W/ACORN) REMOVE	420.00

FIREWOOD: LEAVE (APPROX. 18" PCS.) (AT WORKSITE - DOES NOT INCLUDE MOVING WOOD)	HAUL	TRUCKS: 595
BRANCHES: <u>CHIP</u>	STUMP: LOW CUT	GRIND #2 100 #3 120
WORK AREA: RAKE	STUMP GRINDINGS: <u>LEAVE</u>	HAUL

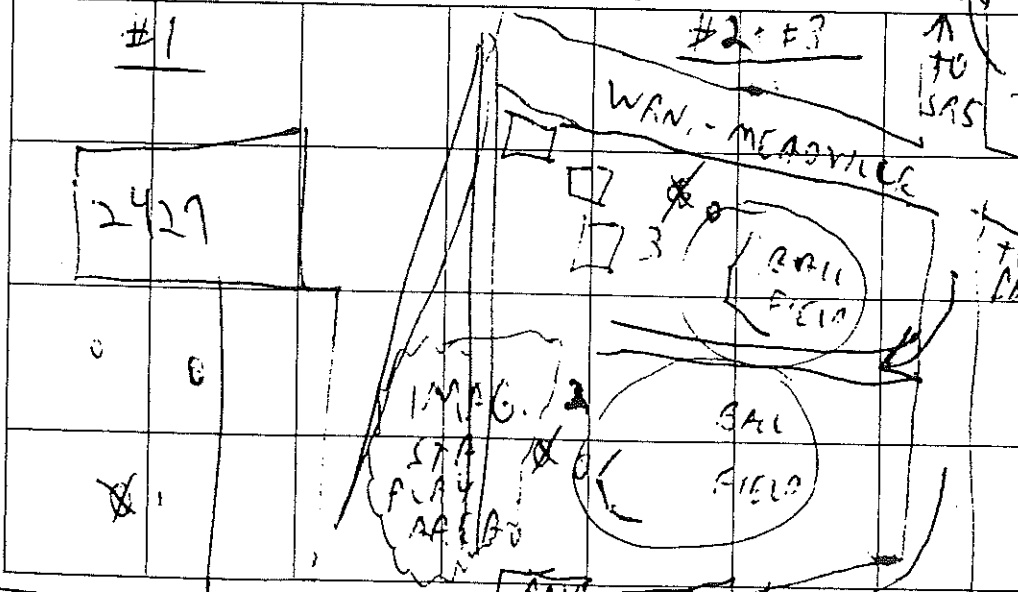

SUBTOTAL	
6.5% / 7.0% TAX	EV
305	TOTAL 815.00

- BAZETTA TREE, INC. IS NOT RESPONSIBLE FOR LAWN DAMAGE DUE TO DROPPING LOGS.
- PAYMENT REQUIRED UPON COMPLETION. WE ACCEPT VISA, MASTERCARD AND DISCOVER.
- BOOKING APPROXIMATELY 1 1/2 - 2 WEEKS AHEAD. THE WEATHER MAY ALTER THE SCHEDULED START AS WELL AS THE PROJECTED FINISH DATE.
- QUOTE IS VALID FOR 30 DAYS.

THE ABOVE ESTIMATE IS HEREBY APPROVED AND BAZETTA TREE, INC. IS AUTHORIZED TO COMMENCE WORK AT THEIR CONVENIENCE.

Signed _____ Date _____

WORK ORDER/ESTIMATE

Bob's Tree Service & Stump Removal



CRANE SERVICE

Fully Insured For Your Protection
1052 North River Rd. • Warren, Ohio 44483
Phone: 394-8516 • 847-0001



Date 5-25-06

Name: Bazetta Road Dept.

Address: _____

Phone No.: _____

Job Site Address: _____

<u>2 - Trees in park</u>	<u>435.⁰⁰</u>
<u>2 - Stumps</u>	<u>280.⁰⁰</u>
<u>1 - Dip Limb on Northview</u>	<u>195.⁰⁰</u>

In the removal of trees there is always some yard damage.
Not responsible for damage to walks or driveways from equipment.
Not responsible for damage to underground utilities and drains. All Jobs Subject to Sales Tax

- Stump Removal YES NO
- Rake Yard YES NO
- Chip Limbs YES NO
- Haul Wood YES NO
- Leave Wood YES NO
- Haul Stump Grindings YES NO



SUBTOTAL
TAX
TOTAL 910.⁰⁰

Date _____

Customer's Signature _____

Bob's Tree Service _____



VENTLING MEMORIALS
5049 Mahoning Ave., N.W.
Warren, Ohio 44483
Phone (330) 847-8500

Office Order No. 0006000

NAME EVERETT B. STANLEY DATE 6-9-66
ADDRESS 3372 ST. PETER'S CITY CLEVELAND
PHONE 330-637-8816 STATE OHIO ZIP 44410

WITNESSETH that for the consideration herein provided, said Purchaser has this day purchased of the following 48" x 17" x 4" GRANITE BACKING

to be manufactured and finished in substantial accordance with the following design, specifications & inscriptions, to wit:

Design No. _____

Dia _____ style top

Polished _____

Base _____

Polished _____

Style letters Family Name EVERETT B. STANLEY

Style letters panels _____

Style letters other _____

Lettered _____ Side (r) _____

Show Sketch of memorial and lettering in space below; also back if lettered.

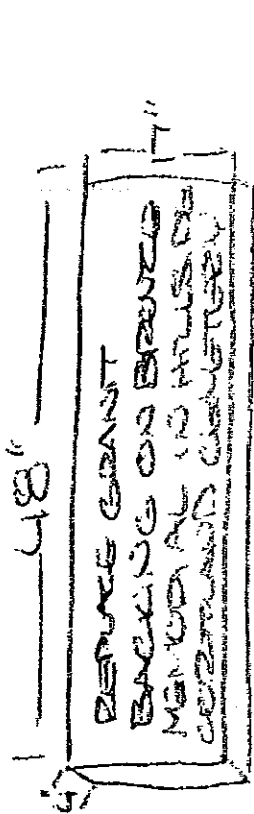

Completion of lettering after work is erected not included in this contract.

It is understood that all material and workmanship shall be of first class quality and that the work and material herein provided for shall be completed on or before the day of May 29, 1966, or within a reasonable time thereafter, and the Company shall not be responsible for delays by strikes or other causes beyond its control, such delays, if any, shall for the period of their duration, be considered as an extension of time of completion provided herein.

It is understood and agreed that the Purchaser shall pay for said property in time, manner, and amount as follows:
Amount: Five hundred and no/100 dollars
Time and Manner: Work done in cash

It is agreed that title to this property shall remain in The Ventling Memorial Company until fully paid for and in case of default in making any payment herein provided for, said Company or its representatives are hereby authorized and empowered to go upon the lot where the same is located and remove the same from the cemetery and shall not be liable to restore said lot to any previous condition, and the Purchaser hereby waives the right to any damages caused by reason of said entry and removal and it is further understood and agreed that this agreement shall constitute an order upon The Cemetery Association where said property may be located to permit Company to remove said property from said cemetery if not fully paid for.

This agreement except as hereinafter provided is not subject to countermand and in the event of any notice or attempt by Purchaser to countermand or rescind the same, said Company shall be released as its option from any obligation to make delivery of the property herein described and said Company shall nevertheless be entitled to full payment upon receipt by the Purchaser of twenty-five per cent of the total sale price herein provided but only in the event that it has not commenced work on said lot and/or especially purchased material for the same prior to the receipt of said notice.

It is further expressly understood and agreed that as between the parties hereto or otherwise, any property delivered hereunder to or for the Purchaser shall remain personal property until fully paid notwithstanding the fact that the same may be firmly affixed to the realty.

It is expressly agreed that no sales representative of said Company has any authority to make any representations not expressly contained herein, and that this instrument when approved contains the full agreement between the parties hereto and no other promises or provisions not contained herein are to be implied or to be considered a part hereof unless the same may be in writing executed on behalf of the Company by a representative thereof duly authorized to do so.

This agreement is binding upon said Company only upon approval and acceptance in writing.
IN WITNESS WHEREOF the parties hereto have signed, executed and delivered this instrument the day and year above written.

Name of Cemetery ANTHONY'S Dealer [Signature]

YOU, THE BUYER, MAY CANCEL THE TRANSACTION AT ANY TIME PRIOR TO MIDNIGHT OF THE THIRD BUSINESS DAY AFTER THE PURCHASER DATE OF THE TRANSACTION. SEE THE ATTACHED NOTICE OF CANCELLATION FOR AN EXPLANATION OF THIS RIGHT.

114



Cell (330) 233-3491

Gregory Dean
8988 Newton Falls Road
Ravenna, Ohio 44266
(330) 358-2068

Toll Free 1-866-358-2068

NAME Cortland Cemetery
ADDRESS _____
CITY _____
PHONE _____ DATE 5/25/06

QTY.	ITEM	SIZE	QTY.	ITEM	SIZE
	STYLE			POST CAPS	
	FABRIC			LOOP CAPS	
	LINE POSTS			RAILS ENDS	
	TERMS POSTS			TIE WIRES	
	TOP RAIL			NUTS & BOLTS	
	TENSION BARS			WALK GATES	
	TENSION BANDS			D. DRIVE GATE	
	BRACE BANDS			GATE HARDWARE	

WE HEREBY PROPOSE TO FURNISH ALL MATERIALS AND PERFORM ALL LABOR NECESSARY FOR THE COMPLETION OF:

C/O Frank Panke 637-8816
637-4518

Repair 5' Fence
Damage/replace posts
Fix broken corner and
level posts need to
damage/rise off

total \$400.00

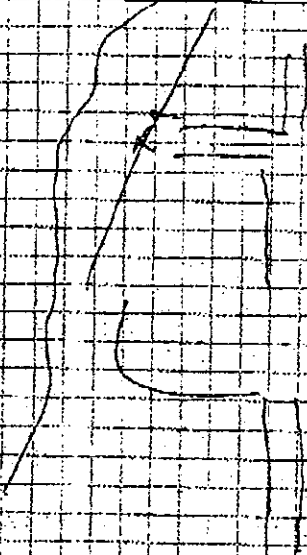

Res # 138-06

05A09

ALL MATERIAL IS GUARANTEED TO BE AS SPECIFIED, AND THE ABOVE WORK TO BE PERFORMED IN ACCORDANCE WITH THE DRAWINGS AND SPECIFICATIONS SUBMITTED FOR ABOVE WORK.

PAYMENTS TO BE MADE AS FOLLOWS:

5% INTEREST ON UNPAID BALANCE OVER 30 DAYS FROM INVOICE DATE.
BUYER IS TO ESTABLISH PROPERTY LINE STAKES AND REMOVE OBSTRUCTIONS THAT MAY INTERFERE WITH ERECTION. BUYER ALSO AGREES THAT CONTRACTOR WILL NOT BE HELD RESPONSIBLE OR LIABLE FOR ANY DAMAGE TO UNDERGROUND OBSTRUCTIONS OR INSTALLATIONS.

ACCEPTANCE

THE ABOVE PRICES, SPECIFICATIONS AND CONDITIONS ARE SATISFACTORY AND ARE HEREBY ACCEPTED YOU ARE AUTHORIZED TO DO THE WORK AS SPECIFIED. PAYMENT WILL BE MADE AS OBTAINED ABOVE.

CONTRACT ACCEPTED

DATE

Cell phone # 330-233-3491 Greg Dean

**TIMBER CREEK HEIGHTS LIGHTING DISTRICT PUBLIC HEARING
HELD AT TOWNSHIP ADMINISTRATION BUILDING
MONDAY, JUNE 19, 2006 AT 6:00 PM**

Present: Bill Glancy, Mike Piros, Jeff Bates and Robyn Metheny.

The meeting was called to order by Mr. Glancy then turned over to Mr. Piros.

The purpose of this hearing was to discuss Timber Creek Heights Lighting District which involves Bianca Lane, Keystone Trail and Corner Stone Drive.

Those in the audience consisted of Frank O'Brian and LuAnn Koch from Ohio Edison and three residents of Timber Creek Heights.

Mr. Piros introduced the representatives from Ohio Edison and explained the process which started back in September/October of 2005 at which time there was no commitment. Mr. Piros noted that the township would need 80% of the homeowners to say yes to move the project forward and the township would also need a commitment from the residents by their meeting on July 17, 2006.

Mr. Piros explained that the district consisted of 31 homes and the estimated cost for 13 lights and installation would total \$18,723.64. He also stated that Bazetta Township pays the up front cost and through a tax assessment the money is returned to the township over a two year period.

Mr. Piros asked if there were any questions.

One resident questioned the time limit. Mr. Piros replied the bids were good for 90 days.

There was a concern of who is responsible for the maintenance. Mr. O'Brian stated that Ohio Edison takes care of the maintenance.

It was questioned if Saddle Brook was included in this district. Mr. Piros stated that Saddle Brook was not part of this petition.

**BAZETTA TOWNSHIP REGULAR MEETING
MONDAY, JUNE 19, 2006 AT 7:00 PM**

Present: Bill Glancy, Mike Piros, Jeff Bates and Robyn Metheny.

Eagle Scout Aaron Hanson gave his report on the cemetery project. He stated he should be done by the end of the summer.

JUNE 19, 2006

Mr. Glancy opened the meeting by reading a letter in which he states that he resigns as the Chairman of the Board of Trustees effective immediately.

Mr. Glancy asked for nominations for Chairman.

141-06 Motion by Mr. Piros, seconded by Mr. Glancy to nominate Jeff Bates as Chairman.
Vote on Motion: Mr. Bates YES, Mr. Glancy YES and Mr. Piros YES.

YES 3

NAY 0

Motion Carried.

Old Business:

Mr. Piros mentioned the Timber Creek Heights Lighting District held earlier tonight at 6:00 PM.

Mr. Glancy had nothing to report.

Mr. Bates reported on the two hour Supervisor Refresher course.

Public Participation:

Kathy and Al Parana, 2430 Andrews Drive, were present concerning sewers.

Mrs. Parana stated that 40 years ago when their house was built they were promised by Mr. Yount to have sewers in two years. She stated they do have sewers, but they just need to connect.

She questioned if there were any plans for sewers and if so when. Mr. Glancy stated the county is going to have the East Side Sewer meeting tomorrow night at Candlelite Knolls and mentioned they could attend and would have a chance to speak.

Mrs. Parana also complained about the appearance in front yards when new septic tanks are put in when you want to sell your house. Mr. Parke said per Attorney Finamore when the township took over the roads for this development, they took over everything with it.

Mr. Glancy said the commissioners could care less about the township.

Mr. Piros informed Mrs. Parana that we had sewer petitions at our office and that she should get signatures to get the process started because it would take at least two years. There is no commitment to sign petitions. The Ohio Revised Code must be followed. Petitions were given to her at the meeting.

JUNE 19, 2006

Mr. Piros noted to Mr. Glancy that Mr. Newbrough had called him to set the room up at Candlelite Knolls for the meeting on Tuesday.

Ronald Snell, 3719 Hoagland Blackstub Road, spoke about his problems with his neighbor Mr. Medzie. He has several junk cars, is burning garbage, high grass, and four wheeler problems.

Mr. Bates questioned the Administrative Search Warrant.

Mr. Glancy replied that pictures were taken the first time and why pay for a warrant when everything should have been taken care of the first time by our zoning inspector and police chief.

Chief Sayers stated that under Code 50587, Nuisance, the search warrant would allow him to enter onto the property and take pictures and check out the property. This is the legal process you must go through.

Mr. Glancy disagreed with Chief Sayers.

Mr. Glancy asked Mr. Mauger how many times he has been there and Mr. Mauger replied 3-4 times.

Chief Sayers stated several times that it was outside the scope of my authority to go and remove the vehicles.

Mr. Glancy disagreed and said we should drop the whole system and turn the township into a junk yard.

Chief Sayers stated that if there was a zoning violation, the zoning board must go to the Trustees to make a ruling.

Mr. Glancy replied then why do we need a zoning inspector?

Mr. Glancy repeated the statement that was made at a previous meeting which was when Chief Sayers was asked if the cars were in Timber Creek would they be gone and his reply was yes.

Mr. Glancy again disagreed with Chief Sayers.

Chief Sayers replied that the legal counsel does agree with me.

Chief Sayers was told to proceed with the warrant.

JUNE 19, 2006

142-06 Motion by Mr. Bates, seconded by Mr. Piros to have Attorney Finamore send out a notice to the residence at 3723 Hoagland Blackstub Road of the violation under Ohio Revised Code 50587 which deals with "Nuisance" giving them 30 days from receipt of the letter to clean up the property.

Vote on Motion: Mr. Bates YES, Mr. Glancy YES and Mr. Piros YES.

YES 3

NAY 0

Motion Carried.

143-06 Motion by Mr. Piros, seconded by Mr. Glancy to approve the minutes of the June 05th meeting with corrections. (Frank stated it would take two weeks not one week to mow the bottom of the ditch to the edge of the road. Also, the paragraph concerning Jakubick-Sexton Architects should be removed).

Vote on Motion: Mr. Bates YES, Mr. Glancy YES and Mr. Piros YES.

YES 3

NAY 0

Motion Carried.

The following correspondence was read by Robyn Metheny:

1. Received a letter from Attorney Finamore concerning the Public Records Act.
2. Received a letter from State Representative Randy Law on the results of the May 31st meeting on Mosquito Lake Lodge. They decided to hire Gateway Consultants for a feasibility study.
3. Emails were sent to newspapers on the June 05th meeting and various other meetings and work sessions.
4. Received a fax on State Bill 2686 on Cable Franchising.
5. Received email from Linda Beil on the NIMS Requirements.
6. Received a letter from Attorney Saker, Trumbull County Prosecutor, on the declaration of Material Assistance/non-assistance to Terrorists Organizations.
7. Received from the Trumbull County Commissioners a certified copy of the transcript proceedings for the Annexation of 1.0292 acres of land belonging to Russell Lauer.

JUNE 19, 2006

8. Received the minutes of the June 10th Safety Committee Meeting.
9. Received a letter from the Public Utilities Commission of Ohio in the matter of a request for expanding the Supplement Assistance Program to grant up to \$5,000 for the installation of safety enhancements to local highway authorities on their right-of-way.
10. Received a pamphlet from Partners in Preparedness Conference on September 13th.
11. Received a letter from the Trumbull County Juvenile Court for community service.
12. Received a letter from Attorney Finamore on a Nuisance Abatement Proceedings/Search Warrant on property located at 3723 Hoagland Blackstub Road.

144-06 Motion by Mr. Piros, seconded by Mr. Glancy to approve purchase orders.

Vote on Motion: Mr. Bates YES, Mr. Glancy YES and Mr. Piros YES.

YES 3

NAY 0

Motion Carried.

145-06 Motion by Mr. Glancy, seconded by Mr. Piros to approve payment of bills.

Vote on Motion: Mr. Bates YES, Mr. Glancy YES and Mr. Piros YES.

YES 3

NAY 0

Motion Carried.

Road Superintendent Parke:

Mr. Parke questioned whether the Trustees still wanted him to complete the Monthly Road Sign Inventory Report. It takes about 8 hours each month.

Mr. Bates is to contact the insurance company to see how often it really needs to be done.

There was a motion by Mr. Bates, seconded by Mr. Piros to have a discussion concerning the sidewalk extension in front of the Hillside Cemetery.

Mr. Parke explained that when the sidewalk was put in, the City of Cortland stopped it at the city limits. They are requesting the township pay \$1,770.00 for material and the City of Cortland would do the labor.

JUNE 19, 2006

146-06 Motion by Mr. Bates, seconded by Mr. Piros to table the matter concerning the sidewalk extension in front of the Hillside Cemetery.

Vote on Motion: Mr. Bates YES, Mr. Glancy YES and Mr. Piros YES.

YES 3

NAY 0

Motion Carried.

At the last meeting it was stated that the State Park was getting a grant to repair the main road going through the park back to the docks. Mr. Parke informed the Trustees that he spoke with Rocco Greco from the State Park and was told that they did not apply for a grant because there was not enough money to put toward the grant.

Mr. Parke also notified the Trustees that Randy Smith from the Trumbull County Engineer's office informed him concerning the right-of-way at the administration building did get a variance, but that the deed was never switched over.

Mr. Bates stated he would make a phone call to find out the proper way to get the matter corrected.

Mr. Parke notified the Trustees that he was present at the cemetery when a company came in to place a vase which is not permitted. He stated we do have on file the form that went out to the companies in 2000 and also stated that the information is posted at the cemetery in different locations and also goes out with every deed issued.

147-06 Motion by Mr. Piros, seconded by Mr. Glancy to send the reminder out once again to the companies..

Vote on Motion: Mr. Bates YES, Mr. Glancy YES and Mr. Piros YES.

YES 3

NAY 0

Motion Carried.

Mr. Parke stated that phone calls were received from 10 – 12 residents who requested their property not be sprayed for mosquitoes.

JUNE 19, 2006

Police Chief Sayers:

148-06 Motion by Mr. Glancy, seconded by Mr. Bates to authorize the expenditure of \$1,097.78 to the 717 Credit Union to release a lien on a forfeited vehicle and for the total amount to come out of the Police Equipment Fund.

Vote on Motion: Mr. Bates YES, Mr. Glancy YES and Mr. Piros YES.

YES 3

NAY 0

Motion Carried.

Chief Sayers apologized to the Trustees and stated he would notify them ahead of time in the future.

Chief Sayers requested an executive session with the Trustees at the end of their meeting to discuss possible employee discipline.

Mr. Bates asked the public if they had anything for Road Superintendent Parke.

There was none.

Mr. Bates asked the public if they had anything for Police Chief Sayers.

There was none.

Mr. Bates asked Chief Sayers if he would entertain bringing a part-time officer from part-time to full-time position until Nick Papalas decides whether to come back. It would have to be an agreement in writing that the part-time employee would go back to part-time. This is not going to be an unemployment issue.

Chief Sayers stated he should know in a few days what the union says.

Mr. Bates clearly stated that this is not negotiable.

Fire Chief McKenzie:

Chief McKenzie notified the Trustees that they might see an article in the newspaper stating "Stand Down for Fire Fighters". He informed the public that they would still answer calls, this is a top to bottom apparatus check and safety talks.

JUNE 19, 2006

Mr. Snell questioned the open burning.

Chief McKenzie replied that in Ohio it is illegal to open burn. Our fire department would give two warnings and the third time you would go to court. If the EPA is called out, you would be fined on the spot.

Zoning Inspector Mauger:

Notified the Trustees that there is a lien on 3054 North Park.

The property is starting to get cleaned up at 2216 State Route 46.

Lorraine who he had been dealing with at the health department no longer works there. Another fax was sent to them concerning 460 State Route 305.

Super Wal-Mart should be started by the end of the year.

Bull Run Storage Shed has a hold up due to the septic tank and because of the Trumbull Soil and Water.

Received copy of House Bill 23.

Park Board:

Jack Governor was present.

Complained about how long it took to clean up the park after the Valley Extreme Girls Softball Tournament. He stated that Sunburst had to be called for an extra garbage pick up.

He requested notification of anyone coming into the park to do work. During the Baseball Academy Camp, Bazetta Tree came in to work next to the ball fields. There were too many children in the park for them to be working there.

He also notified the Trustees of bees just outside the Imagination Station.

Mr. Governor questioned the process of ordering supplies needed for the park restrooms.

He was told he could go and purchase the supplies he needed as long as it is within the budget.

JUNE 19, 2006

149-06 Motion by Mr. Piros, seconded by Mr. Glancy to set up a meeting between the park board and the Trustees to discuss possibly requesting a deposit to use the park.

Vote on Motion: Mr. Bates YES, Mr. Glancy YES and Mr. Piros YES.

YES 3

NAY 0

Motion Carried.

Mr. Piros stated that in special event cases, the road department employees should go over and help Mr. Governor in the park.

There was a discussion on taking the section concerning Port-A-Jons out of the zoning book.

Mr. Governor asked how soon he needed to pressure wash the gazebo.

Mr. Piros replied as soon as possible.

Mr. Governor stated he needed extra hose to pressure wash the gazebo. A resident from Andrews Drive, who was present, told Mr. Governor he would donate the hose.

Mr. Governor was also told to remove the tape and signs from the gazebo.

Administration:

There was a reminder on the Drug Free refresher training for all full-time and part-time employees.

Friday, June 23rd 10:00 AM to Noon and Friday, June 30th from 3:00 PM to 5:00 PM.

There will be a video presentation for those who can't make either of the above sessions.

Mosquito spraying is scheduled for Monday, June 26th with the rain date of Tuesday, June 27th.

There will be a work session with the Fire Department Union Representatives Mannella, Rink and White on Monday, June 26th at 8:00 AM at the township hall.

The East Sewer Project is at Candlelite Knolls at 7:00 PM on Tuesday, June 20th.

It was noted that Bazetta Tree sent in all their necessary paperwork to do work in the township park and on Northview Drive.

JUNE 19, 2006

Mosquito spraying was cancelled on May 22nd due to the cold weather. The next available date is Monday, July 17th. Trustees agreed to schedule that date.

There was a motion by Mr. Piros and seconded by Mr. Bates to discuss using a tape recorder at the Trustees meetings.

It is possible that new equipment might need to be purchased in order to tape record the meetings.

150-06 Motion by Piros, seconded by Mr. Glancy to start with the first meeting in August to use the tape recorder.

Vote on Motion: Mr. Bates YES, Mr. Glancy YES and Mr. Piros YES.

YES 3

NAY 0

Motion Carried.

Mr. Piros mentioned he wrote a letter to Norfolk-Southern Engineering concerning complaints received regarding several rail crossings located throughout Bazetta Township. These crossings are Able Road State Route 305, Phillips Rice Road and Hoagland Blackstub Road. He will leave a copy at the township hall for the other Trustees to look over and sign.

Mr. Piros also reminded everyone that there is a Regional Meeting in Howland on June 27th.

Mr. Piros noted that the Trustees have received the Fact Finder Report concerning the road negotiations.

151-06 Motion by Mr. Piros, seconded by Mr. Glancy to accept the Fact Finder Report and Mr. Piros is to contact Mike Seyer.

Vote on Motion: Mr. Bates YES, Mr. Glancy YES and Mr. Piros YES.

YES 3

NAY 0

Motion Carried.

152-06 Motion by Mr. Bates, seconded by Mr. Piros to go into executive session with Chief Sayers to discuss possible employee discipline.

Vote on Motion: Mr. Bates YES, Mr. Glancy YES and Mr. Piros YES.

JUNE 19, 2006

YES 3

NAY 0

Motion Carried.

Trustees went into executive session at 8:50 PM.

No action taken in executive session.

Trustees returned to regular session at 9:50 PM.

153-06 Motion by Mr. Glancy, seconded by Mr. Piro to adjourn the meeting.

Vote on Motion: Mr. Bates YES, Mr. Glancy YES and Mr. Piro YES.

YES 3

NAY 0

Motion Carried.

By Motion Adjourned.

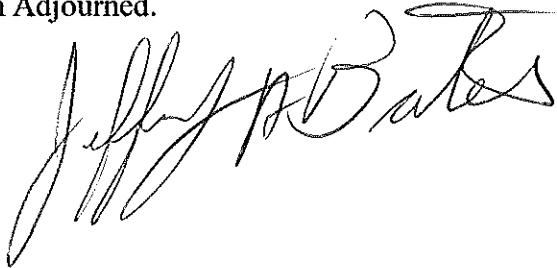
A handwritten signature in cursive script, appearing to read "Jeffrey H. Bates". The signature is written in dark ink and is positioned below the text "By Motion Adjourned."

CITY OF CORTLAND - BAZETTA TOWNSHIP

PROPOSED SIDEWALK DIMENSION 310' long x 4' wide. To be run from the north driveway to the south driveway approximately 5 feet south of the fence. Entire area is located in Bazetta Township.

ESTIMATED MATERIAL COSTS

LINE	ESTIMATED QUANTITY	DESCRIPTION	UNIT PRICE MATERIAL COST	ESTIMATED MATERIAL COST
1	15 CY	Concrete	\$95.00 /CY	\$ 1,425.00
2	23 CY	6" 304 Aggregate (pick-up)	\$15.00 /CY	\$ 345.00
				\$ 1,770.00

MINUTES
Bazetta Township Fire Department Work Session
June 26, 2006

Meeting started at 8:00 AM

Attended: Bazetta Trustees, Jeff Bates, Bill Glancy, Mike Piro

Bazetta Professional Firefighters Local #3703: Mike Mannella, Tom Rink, Mike White

Discussed the addition to the Police Department, and the selling of the existing Township Hall.

They were told it has been tabled due to lack of funds.

Informed of repairs needed for stations 11 and 13.

Fire Department needs to get estimates on repairs for windows and doors meant for station 13.

Chief Clyde McKenzie will present the bids at the next trustee meeting.

Employees wanted to know about painting the interiors of buildings 11 and 13; they were told the materials would have to come out of their supply fund.

Adjured meeting at 9:20 AM

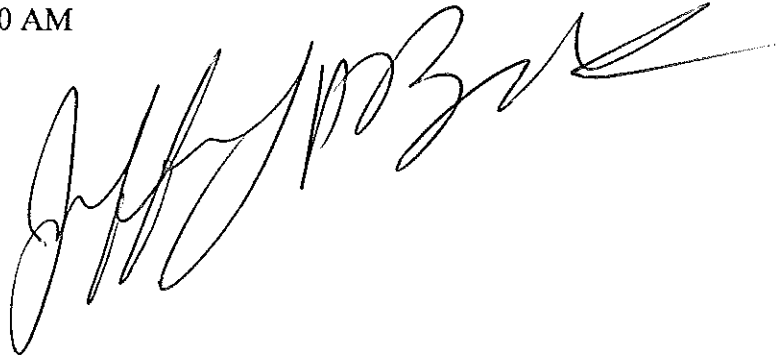
A large, stylized handwritten signature in black ink, likely belonging to Jeff Bates, is written across the lower right portion of the page. The signature is cursive and somewhat abstract, with long, sweeping strokes.

**BAZETTA TOWNSHIP TRUSTEES REGULAR MEETING
MONDAY, JULY 03, 2006 AT 9:00 AM**

Present: Jeff Bates, Mike Piros, and Bill Glancy.

Old Business:

Mr. Piros reported he sent a letter to Norfolk-Southern Railway Company informing them of numerous complaints about three crossings in the township that need repaired; State Route 305, Phillips Rice Road and Hoagland-Blackstub Road.

He attended a Regional Fire and EMS Service meeting at Howland with several other townships. This meeting was to find out if there is an interest in regionalizing fire and ambulance services. We are to complete a survey detailing our priorities of areas of evaluation. When all the surveys are complete, the committee will look at hiring a consultant for a feasibility study. The next meeting will be August 01st. The cost of the consultant needs to be worked on, as it is not fair for all townships involved to split the cost down the middle because of the different budgets and population. For example, Howland population and budget is 2 ½ times larger than ours. We have 6,300 residents.

Mr. Glancy met with Mike Seyers, our Road Negotiations Representative along with the other two Trustees on June 19th at 8:00 AM. He also attended the Timber Creek Heights Street Lighting Project meeting on June 19th at 6:00 PM. Only three residents showed up.

He also attended with the other Trustees the Eastside Sewer Project at Candlelite Knolls at 7:00 PM on June 20th. Mr. Glancy attended the work session with the fire department at 8:00 AM on Monday, June 26th. Trustee Glancy and Piros attended the Regional Fire and EMS Service meeting at Howland on June 27th. On Wednesday, June 28th Mr. Glancy met with a Trustee from Springfield on their road negotiations as their union is requesting the Teamsters to represent them.

Mr. Piros said Trumbull County Commissioners Dan Polivka called him saying the commissioners should take action on the East Side Sewer Project in two weeks. Large sewer project 1.7 million. The commissioners gave \$160,000 to an engineering company to do the study. Mr. Glancy interjected by saying this Bazetta Board of Trustees are working on sewers every week.

Mr. Bates stated he would attend an all day class in September for BWC to be in compliance for next year.

Public Participation:

Mr. Darl Peterson, 1153 Harvest Drive, said he got 67" of water in his basement last Friday and

JULY 03, 2006

158-06 Motion by Mr. Bates, seconded by Mr. Glancy to send Chief Sayers to the Partners in Preparedness Conference sponsored by the American Red Cross on September 13, 2006 at the Avalon Inn at a cost of \$65.

Vote on Motion: Mr. Bates YES, Mr. Glancy YES and Mr. Piros YES.

YES 3

NAY 0

Motion Carried.

159-06 Motion by Mr. Piros, seconded Mr. Glancy to send Chief Sayers to a one-day workshop entitled "Internet Safety – Train the Trainer" in Columbus sponsored by the Ohio Attorney General's Office with no cost for tuition, but travel expenses will apply.

Vote on Motion: Mr. Bates YES, Mr. Glancy YES and Mr. Piros YES.

YES 3

NAY 0

Motion Carried.

Mr. Piros suggested that Chief Sayers invite the public here after he completes this seminar. Chief Sayers said he would like this implemented into the Lakeview School District.

Administration:

160-06 Motion by Mr. Piros, seconded by Mr. Glancy to authorize the Fiscal Officer to transfer monies within the following funds:

01-A-27 (General Transfers) to 01-C-07 (General Repairs) \$1,600 (Note: Insurance money received for squad striping)

01-F-02 (Park Improvement of Sites) to 01-F-08 (Park Other Expenses) \$750

10-A-01A (Fire Salary – Part-time) to 10-A-09 (Fire Supplies) \$7,500

03-A-07 (Gas Tax Maintenance of Equipment) to 03-A-03 (Road BCW) \$4,917.84

01-A-27 (General Transfers) to 01-A-15 (General BWC) \$5,282.96

Vote on Motion: Mr. Bates YES, Mr. Glancy YES and Mr. Piros YES.

YES 3

NAY 0

Motion Carried.

JULY 03, 2006

161-06 Motion by Mr. Glancy, seconded by Mr. Piros to authorize the Fiscal Officer to transfer monies in the amount of \$4,600 from the following fund:

01-A-27 (General Transfers) to 05-A-07 (Cemetery Repairs) \$1,000

01-A-27 (General Transfers) to 05-A-09 (Cemetery Supplies) \$2,000

01-A-27 (General Transfers) to 05-A-04 (Cemetery BCW) \$1,600

Vote on Motion: Mr. Bates YES, Mr. Glancy YES and Mr. Piros YES.

YES 3

NAY 0

Motion Carried.

162-06 Motion by Mr. Glancy, seconded by Mr. Piros to Authorize the Fiscal Officer to request a new "Certificate of Estimated Resources" from the Trumbull County Auditor from General 01 Fund to Cemetery 05 Fund in the amount of \$4,600.

Vote on Motion: Mr. Bates YES, Mr. Glancy YES and Mr. Piros YES.

YES 3

NAY 0

Motion Carried.

Mr. Bates left the meeting at 9:30 AM to go to work and Vice Chairman Piros took over the meeting.

Fire Chief McKenzie:

Chief McKenzie reported that he would be attending the Ohio Fire Chief's Conference in Columbus on July 19th through the 25th. He will be a candidate for Second Vice President of the Ohio Fire Chief's Organization for 2007. If elected, he will be First Vice President in 2008 and President in 2009. Mr. Piros asked if this was for the whole state of Ohio and the reply was yes. To run for Second Vice President, he will give up his Sergeant at Arms position.

Mr. Glancy asked when the new ambulance would be here and the reply was July 18th.

Chief McKenzie said we are borrowing a vehicle from Brookfield Township as a spare to get us through the fair, which is July 09th through the 16th. The fair board agreed to pay \$200 per day for one man from the hours of 1:00 PM to 8:00 PM inside the fairgrounds to stand by in case of an emergency. That person will contact the station for assistance. The evening events will be contracted out by the fair board for a private company.

JULY 03, 2006

Due to a medical emergency for his wife, Road Superintendent Frank Parke was unable to attend the meeting.

Zoning Inspector Mauger:

Mr. Mauger gave his monthly report and said he is working on abandoned houses and working with the Trumbull County Health Department as their representative quit a few months ago.

Mr. Mauger informed the Trustees he sent out two certified letter on property at 466 Wilson-Sharpville Road and 3723 Bazetta Road. These property owners have 30 days from the date of the letter to clean up their property.

Mr. Glancy asked about the high grass at 3723 Bazetta Road, as it is 10' from his house. Mr. Piros said each incident has to be declared a nuisance per legal counsel. We can not do a blanket motion. Each time requires a new resolution. The cost of the township to do this will go o the property owner's taxes with money returned to the township once the property is sold or property taxes are paid.

Mr. Glancy said the fire department took a census and there are 27 vacant houses in the township.

Per the auditor, Mr. Mauger said Trumbull County has 800 foreclosures and the sheriff sale is two years behind.

Mr. Mauger said there is property with 4' grass, garage falling in and a car jacked up with no tires on and no one knows where the property owners are.

Mr. Piros said the problem is the mortgage companies are difficult to locate as they are out of state.

Chief McKenzie asked Mr. Mauger about the property at ³⁰⁵⁴460 North Park and the reply was there is a lien filed against it and nothing can be done at the present time. *mjm 7/19/06*

Mr. Glancy said most people have liens or mortgages on their houses.

Mr. Mauger asked the Trustees if some community organization, the Boy Scouts, could mow the high grass in the township and Mr. Glancy said no as they can't operate any motorized equipment and could get bitten by something. Then the township would be liable.

JULY 03, 2006

Safety Committee:

Chief Sayers had nothing to report.

Administration:

Mr. Piros reminded everyone of the July 14th deadline for the Fall Newsletter. He thanked Chief McKenzie for his report.

Mr. Mauger asked the Trustees to write a letter to the Zoning Board regarding House Bill #23 which expands the authority of local governments to regulate adult entertainment establishments. Mr. Piros will try to attend the July 05th zoning meeting.

Mr. Piros reminded everyone of the following meetings:

- July 05th at 8:00 AM – Road Negotiation Meeting
- July 05th at 7:00 PM – Zoning Meeting
- July 12th at 7:00 PM – Zoning Meeting

Mr. Piros said he has received several calls on why we cannot get a grant for the sewer projects. The township doesn't qualify. Just because we have a lot of people on fixed income doesn't mean we can get a grant. It requires majority of residents to be below the poverty level, which is \$525 a month.

163-06 Motion by Mr. Glancy, seconded by Mr. Piros to adjourn the meeting at 10:10 AM.
Vote on Motion: Mr. Glancy YES and Mr. Piros YES.

YES 2
NAY 0
Motion Carried.

By Motion Adjourned.

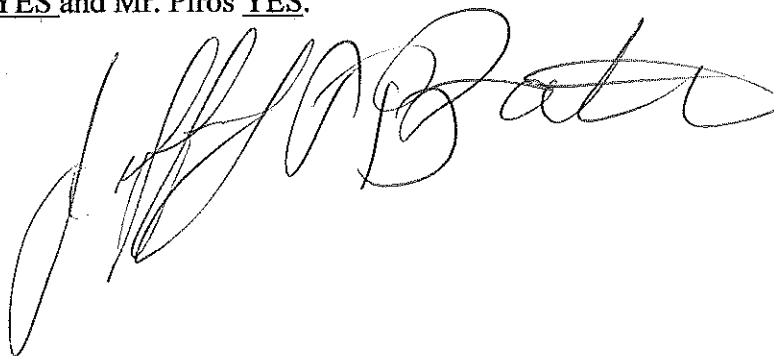

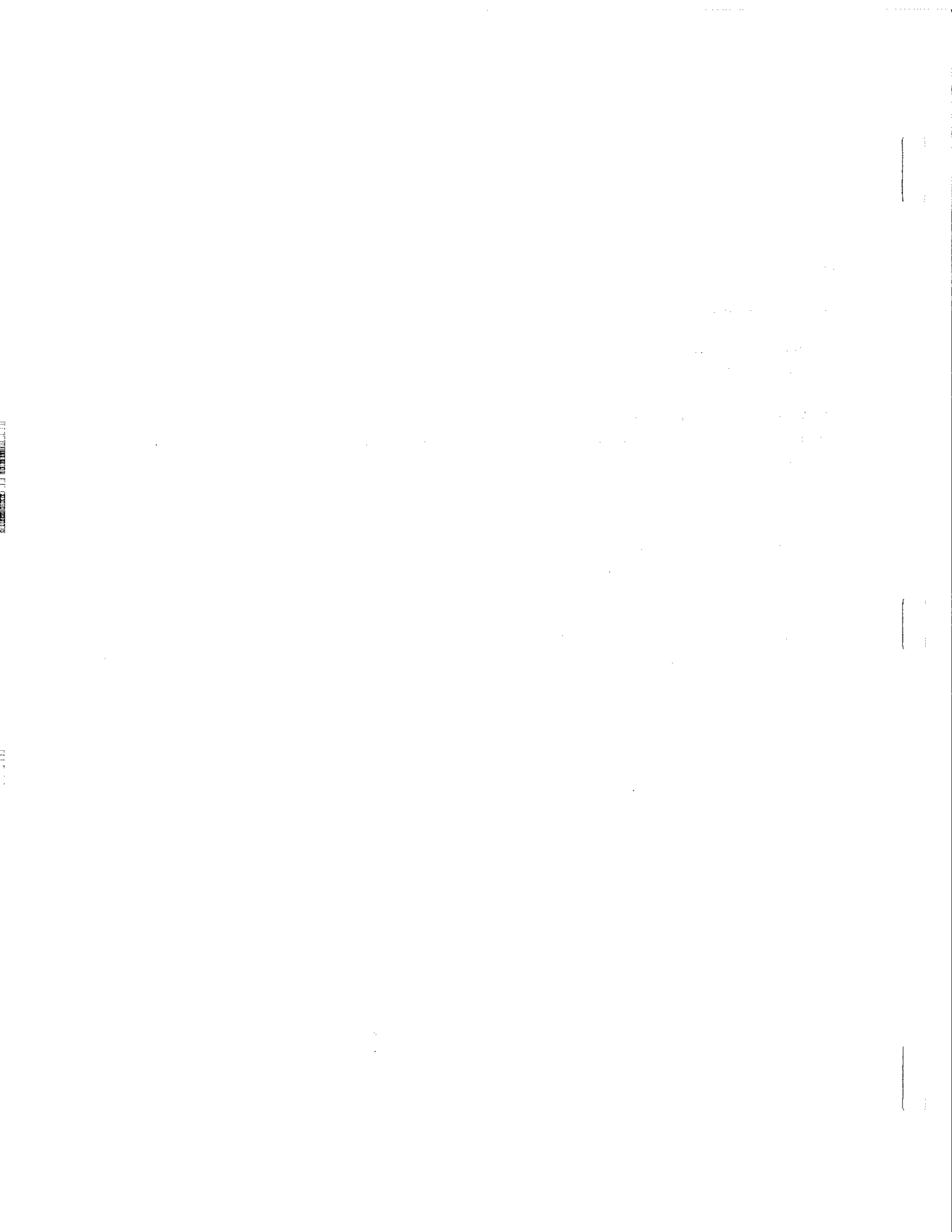

**BAZETTA TOWNSHIP TRUSTEES REGULAR MEETING
MONDAY, JULY 17, 2006 AT 7:00 PM**

Present: Jeff Bates, Mike Piros, and Bill Glancy and Mark Finamore, Legal Counsel
Brian Prunty, Urban Specialist, & Soil & Water Conservation District (SWCD)
Marly Kosinski, Reporter from the Tribune
Sabrina Lardis, Reporter for WYTV 33 News

Mr. Bates introduced Brian Prunty of the Soil and Water Conservation District who will address any flooding concerns.

Old Business:

Mr. Piros reported he checked with the office of the Trumbull County Commissioners and was told that the Eastside Sewer Project was not on their last week meeting agenda. It should be in a couple of weeks.

Mr. Piros contacted Gary Newbrough on Issue I grant money of \$300,000, which was rejected. Gary will re-submit this request for Issue I grant money of \$300,000 again next week.

Mr. John Campolita, 2280 Cornerstone submitted a petition with 28 signatures on it for the approval to install streetlights in Timber Creek Heights. There are 31 homes affected, 2 said no and one was not home.

Mr. Glancy said he received many phone calls on water problems and cemetery problems. After taking a ride through Hillside Cemetery, he stated the cemetery looks terrible.

Mr. Bates said he received a sewer petition for Andrews Drive Development and will take it to the Sanitary Engineer's Office.

Public Participation:

Mr. Tom Hyde, 2660 McCleary Jacoby Road, had concerns about his neighbor's pond draining onto his property. He thanked Mr. Glancy who came out last week to look at this problem. Mr. Prunty was also at this site and suggested three options for the owner of the pond. Mr. Hyde is concerned about if the property owner does not abide by these recommendations.

Mr. Finamore stated it is a civil suit between the neighbors and to get a legal junction after the water flow is unreasonable. The township trustees do not have any jurisdiction in this matter. Mr. Finamore told Mr. Hyde to re-inspect the pond and give this information to his lawyer for him to take action.

JULY 17, 2006

Mr. Hyde wanted to know in the future if there is anything in the zoning regulations about building ponds like this one which is right on the property lines. Mr. Finamore said water problems are outside of zoning regulations.

Mr. Glancy suggested to Mr. Hyde that he attend the next zoning meeting with his concerns.

Mr. John Tomko, McCleary Jacoby Road, also voiced his concerns on the same pond problems.

There being no further questions, Mr. Prunty left the meeting at 7:45 PM.

Cheryl Tennant, Perkins Jones Road, asked about moving the township administrative offices to the police station. Mr. Glancy said this was tabled at the present time due to the budget. She informed the trustees they cannot move this office without the consent of the voters per ORC511-01.

She also asked how long the Deputy Clerk from Howland is going to be helping Martha. Martha replied she comes out once a month to make sure we will have a clean audit in 2007. Martha attended OTA Winter Conference in February, 2006 and attended workshops that were available earning credits of 6.25 hours. Mrs. Tennant said there are classes in Warren that Martha can take and will get her the information.

Mrs. Tennant had copies of the township's cell phone bill and usage of each employee that she handed to the trustees, Martha and Mr. Mauger. She said there were many personal calls made from the township issued cell phones. She wanted to know if we had a cell phone policy and the reply was no. You can't use public property for personal use. She also wanted to know who voted to have cell phones as she didn't have one when she was a trustee. Mr. Glancy said everyone has a cell phone.

Mr. Governor, McCleary Jacoby Road, works in the township park and said he was told his cell phone was for business calls only.

Robyn Hineman, Northview Drive, wanted to know who has cell phones. We issued 24 cell phones to include the Road, Police, Zoning, Trustees, Martha and Robyn.

Mr. Finamore said most townships issued cell phone to officials and the department heads. The State Auditor gives government entities three options for cell phone policies. One is a reimbursement option where the employee uses his or her personal cell phone for business and gets reimbursed. Second is township paid cell phones which the employee uses a township-issued phone, but can use it for business. The third option allows the employee to use the phone for business and personal use, but the employee pays a set percentage of the bill for their personal usage.

JULY 17, 2006

Mrs. Tennant said that is fine for the future, but questioned who will pay these charges back to the township.

Mr. Piros said the trustees would look over these bills. The minutes are purchased as a pool and divided among all users.

Mrs. Hineman suggested to the board that they re-look at who should get a cell phone.

Mr. Bowen, State Route 5, said we have changed phone companies so many times in the past.

Mrs. Tennant re-emphasized, "Do not use public property for personal use".

Mr. Hineman asked Mrs. Tennant how many personal calls were made on company time and the reply was quite a few.

Mr. Finamore suggested again that the trustees should look at who really needs a cell phone.

Mr. Finamore told the public that the township is in the process of establishing a cell phone policy.

Mr. Bob Rozycki presented his case about his son, Ryan's, car being stolen twice. The first time was on July 13th at the Speedway Gas Station on Market Street in Warren, and the second time was on July 14th at Perkins Restaurant in Bazetta.

Ryan was on his way to work when he noticed his car parked at Perkins Restaurant on July 14th. He called 9-1-1 and was told that a police officer from Bazetta would be there shortly. Chief Sayers responded and told Ryan to go home (which is only 15 minutes away on Perkinswood) to get his second set of keys and Chief Sayers would stay with the car until his return. In the meantime, Chief Sayers receives another call of an apparent break in and goes to that call leaving Ryan's car unattended. Ryan returns from home and both his car and Chief Sayers are gone. Mr. Rozycki told the public to not vote for any police levies, as they aren't doing their job. He suggested to Chief Sayers he should have called for assistance on his cell phone. Mr. Rozycki asked Mr. Finamore "if that guy in Perkins had a gun, where would I be tonight? After no response, Mr. Rozycki emotionally left the meeting.

Mrs. Hineman interjected that when she needed the police, they weren't there for her either.

Mr. Bowen stated we are told there are always two on duty for every shift.

Mrs. Hineman said she was trying to teach her son auto safety and told him not to use his cell phone while driving. While she was out for a drive with her son, she noticed Bazetta police officers talking on their cell phones while driving. They should set the example for our young people.

JULY 17, 2006

Mr. Bates mentioned Ryan Rozycki called him on Friday and he told him to write down everything that happened so the board could review the situation and take disciplinary action, if necessary.

Mr. Bates said that at the last meeting, the board and Chief Sayers discussed coverage at the fair and we were told road patrols would not be affected. But now I hear the Chief was the only one on duty that day.

A work session was scheduled for Wednesday, July 26th at 8:00 PM at the administration building with the police department.

Bill Tomsich, 3071 Bazetta Road, suggested that the trustees get active and impose a Clean Water Tax for all the sewer problems in the county. He has had conversation with Commissioner Heltzel and State Representative Law on this. He says everyone should pay for sewers - \$50 per year for residents without septic tanks and \$150 per year for residents with septic tanks, which would be put on their tax duplicate. In 30 years we can see progress. The money spent now is costly and it is still a septic tank. There will be upgrades on a yearly basis plus pumping and the filter beds have to be cleaned. Mr. Tomsich doesn't think the Commissioners and the Board of Health are being considerate in this matter. He gave an example of his former employer, Grant Oaks, who had to drill twice for water. We are ruining our water supply. He further stated that the upgrade of Sterling Drive Plant for the Lakeshore Allotment is about 1.5 million. He suggested to the trustees that they get together with other townships and work at getting something done countywide.

Mr. Finamore said he is the Vice President of the Trumbull Township Association and we have sent resolutions to the state requesting money for our county's sewer projects. The only problem is the money goes to the city first then the townships. Mr. Finamore said to get what Mr. Tomsich suggested would have to go on the ballot and the people with sewage systems would not vote for it.

Mr. Glancy said we have three powerful people, the commissioners, but whom all live in the city and they don't care. We have been fighting this for years.

Mr. Finamore said the state should pass a law.

Mr. Glancy said the septic tanks that are put in today might not be approved in a year.

Mr. Tomsich mentioned the septic tank on Bazetta Road, which was put in when the house was built about three years ago and had to be replaced recently. He wanted to know if everyone knew which septic tank he was talking about. The reply was yes.

Harley Tennant, Perkins Jones Road, said no one gave any money to him when he had to replace this septic tank at a cost of \$15,000.

JULY 17, 2006

Pearlene Lyman, Westview Drive, said their street sewer project is in the engineering stage now and asked why does it take so long for a simple project.

Mr. Finamore said the Sanitary Engineer outsources to an independent engineering firm so there is no conflict of interest.

Mrs. Hineman said at their meeting on June 20th no one stood up to say anything against the sewer project.

Mr. Finamore said the commissioners and health board are forcing us to bite the bullet.

Mrs. Hineman said we can't sell our houses because of the septic issue.

Mrs. Lyman referred to the lost \$300,000 grant money. Who applies for this? Mr. Finamore said the county does, as the township has no authority and said there are no grants for sewer projects. Issue I money can only be used for sewers. Mr. Finamore pointed out that the county put up \$800,000 for the Vienna Airport sewer project.

Mr. Piros said the Ohio Department of Development is for industrial not residential.

Mr. Finamore suggested to Mrs. Lyman that she go to a Commissioner's meeting.

Mr. Tennant said Yount put in sewers on Perkins Jones Road up to the apartments so he could sell off his property lots. He tied in and paid for his own. Yount paid for the sewers and the money from homeowners that tied in is just sitting here and will have to go to Yount's estate as he just recently passed away. He said the estate should get the money, not the county.

Mr. Bowen asked about the sinkhole on Bazetta Road that Yount put a pipe underneath the garage many years ago. The trustees along with the Road Superintendent, Police Chief and Fire Chief were at the scene and since this comes from a private drive, Harvest Drive, under a county road, the trustees have not jurisdiction.

Mr. Piros said the distribution is not equal. Mahoning gets double what Trumbull gets.

Mr. Finamore said there is an application you must fill out to certify 10 years of infrastructure. Seems it all goes to Mahoning County, Youngstown and then Trumbull. Townships go into small government units and the township with the most population gets the most points and city and county with the big projects like sewer and water.

JULY 17, 2006

164-06 Motion by Mr. Glancy, seconded by Mr. Piros to approve the minutes of the July 03rd meeting.

Vote on Motion: Mr. Bates YES, Mr. Glancy YES and Mr. Piros YES.

YES 3

NAY 0

Motion Carried.

The following correspondence was read by Fiscal Officer Martha Urchek:

1. Letter from Mark Finamore to Aaron Hanson on his donation for the bench for the West Bazetta Cemetery.
2. Letter from Ohio Department of Natural Resources on the Development of Abandoned Mine Lands.
3. Emailed local newspapers on last month's meeting minutes and upcoming meetings and projects.
4. Martha attended the Mahoning Valley Safety Council's luncheon on July 12th on Worker's Compensation Claims Management. We are following all the rules and regulations set forth by the BWC, our TPA and MCO.
5. Faxed the Fire Service Cooperative Enhancement Study – Areas of Evaluation to Darlene St. George on the Regional Fire and EMS Service Committee.
6. Closing of Drummond Avenue over Interstate 80 from the Ohio Department of Transportation.
7. Fax from Trumbull Soil and Water Conservation District on the development of a proposed storm water district in Trumbull County.
8. Letter from the Ohio EPA stating water quality sampling at the Mahoning River basin will take place in October of 2006.
9. Division of Liquor Control stating all permits to sell alcoholic beverages will expire on 10/01/06.

165-06 Motion by Mr. Piros, seconded by Mr. Glancy to approve purchase orders.

Vote on Motion: Mr. Bates YES, Mr. Glancy YES and Mr. Piros YES.

JULY 17, 2006

YES 3

NAY 0

Motion Carried.

166-06 Motion by Mr. Glancy, seconded by Mr. Piros to approve payment of bills.
Vote on Motion: Mr. Bates YES, Mr. Glancy YES and Mr. Piros YES.

YES 3

NAY 0

Motion Carried.

Fire Chief McKenzie:

Chief McKenzie reported the new ambulance will be delivered on Thursday, July 20th.

Road Superintendent Parke:

Mr. Parke reported he received a tire grant check in the amount of \$655.50.

Mr. Piros told Mr. Parke that the Soil and Water Conservation District is applying for capital improvement projects and asked him to submit some areas of flooding problems. Mr. Parke will send a report listing; one on Henn Hyde Road and two on McCleary Jacoby Road.

Mr. Glancy asked about the flooding on Prince Drive. Mr. Parke said the pipe was plugged up and that there was some tile put in some 25 years ago which was not the correct size. This needs to be done again. Mr. Glancy said the water runs down from the woods.

Mr. Parke said there was additional flooding on Bazetta Road at Harvest Drive and on McCleary Jacoby Road by Bob Luscher's house.

Mr. Tomsich said 3" of rain fell within an hour.

Mr. Parke said that Durst Clagg was blocked for a period of time because of flooding. The creek overflowed on Williams Drive.

Mr. Bates asked Mr. Parke to add these to the list to Soil and Water.

He is installing tile and catch basins plus he has two mowers in the cemetery.

JULY 17, 2006

Mr. Piros said he got a complaint about the homeowner at 2354 Keystone Trail who re-directed a tile to the road. Mr. Finamore will send the homeowner a letter stating the township can do the work at his cost or he can correct the situation himself. Mr. Prunty is aware of this problem.

Mrs. Hineman asked Mr. Parke about how the road negotiations are going and Mr. Piros stated a final proposal is being prepared and hopes it will be ready for a vote by the Teamsters Union within the next several weeks.

Police Chief Sayers:

Police Chief Sayers reported that he was elected to be the Project Manager for 2006 Mobile Data Terminal project. His job will be to utilize monies for MDT's throughout the county.

He submitted his monthly report as well as his semi-annual report.

His request for continuing professional training for his department was tabled and will be discussed at the work session on July 26th.

His request for an executive session to discuss possible employee discipline will be after the meeting.

167-06 Motion by Mr. Piros, seconded by Mr. Bates to transfer \$14,054.73 from 09-A-14 Police (Other Expenses) to 09-A-03 Police (Bureau of Worker's Compensation).

Vote on Motion: Mr. Bates YES, Mr. Glancy YES and Mr. Piros YES.

YES 3

NAY 0

Motion Carried.

Mr. Piros asked Chief Sayers if he had anything to report on the taping equipment for the meetings as the deadline is for our next meeting, August 07th. Chief Sayers stated he hasn't heard from the original vendor and asked if he can pursue another and the reply was yes. Mr. Piros said we could use the old equipment if necessary.

Mrs. Hineman asked about the money for BWC and it was because the premium was miscalculated in the beginning of the year.

Mrs. Hineman also asked if the police officers were on an exercise program as she feels some of them would have a hard time if they had to chase a criminal on foot. She said one officer looks like his vest is killing him. Chief Sayers will research this.

JULY 17, 2006

Mr. Tennant asked if the BWC records were public and the reply was yes with some exemptions on the diagnosis and personal information.

Zoning Inspector Mauger:

Mr. Mauger reported that the structure at 3054 North Park can be demolished as the lien has been taken care of.

168-06 Motion by Mr. Piros, seconded by Mr. Glancy to proceed with the demolition of the structure at 3054 North Park Avenue.

Vote on Motion: Mr. Bates YES, Mr. Glancy YES and Mr. Piros YES.

YES 3

NAY 0

Motion Carried.

Mr. Tomsich asked about the Krantz property on Bazetta Road and Mr. Mauger has talked with her and she doesn't own the property now and doesn't know who does.

Mr. Tennant asked about garage sales as to how many one can have in a year and how many days. Mr. Mauger said that a resident could have two garage sales per year, three days per garage sale. Mr. Tennant said that the log cabin house on Perkins Jones Road has a year-round garage sale. He calls her the Wal-Mart Annex. Mr. Mauger said he has talked with her and Mr. Tennant says stop talking to her and stop her garage sales. Mr. Mauger will look to see if she paid for a garage sale and if not, will stop and see her and if she is having a garage sale without a permit, he will mail her a notice that she will be fined \$5 for every day she has a garage sale without a permit.

Mr. Piros asked Mr. Mauger about the vacant lot in Timber Creek which is owned by Doctor Ashdown. Mr. Mauger stopped there and talked with two nannies. They told him the owner is trying to find someone to cut down the high grass with a brush hog.

Safety Committee:

Chief Sayers had nothing to report.

JULY 17, 2006

Administration:

Mr. Piros asked Mr. Finamore about a flooding problem on Larry Lane which is a privately owned trailer park. The owner does not want to do anything. Mr. Finamore said this is private property and suggested he forward this complaint to Mr. Prunty of SWCD as the township has no jurisdiction.

Mr. Piros asked the department heads if they use co-op purchasing and the reply by all three department heads was yes.

169-06 Motion by Mr. Piros, seconded Mr. Glancy to pay \$100 to Co-operative Purchasing Program from July 01, 2006 through June 30, 2007.

Vote on Motion: Mr. Bates YES, Mr. Glancy YES and Mr. Piros YES.

YES 3

NAY 0

Motion Carried.

Regarding the request from the Board of Elections to host a meeting to educate the voters that there is a new ID requirement for the November 2006 General Election, Mr. Glancy suggested that Martha call them and ask for a date and time and we would advertise and if the public comes, they come. Mr. Piros said he would put something to this affect in the fall newsletter.

Mr. Bates will have a work session with Road Superintendent Frank Parke on the signage for the township as far as the suggested requirements set forth by OTARMA, our insurance carrier.

170-06 Motion by Mr. Bates, seconded by Mr. Glancy to approve the Alternative Tax Budget.

Vote on Motion: Mr. Bates YES, Mr. Glancy YES and Mr. Piros YES.

YES 3

NAY 0

Motion Carried.

After some discussion on Trick or Treat night the following motion was made:

171-06 Motion by Mr. Piros, seconded by Mr. Glancy to set Trick or Treat Night for the township on Tuesday, October 31st from 6-8 PM.

Vote on Motion: Mr. Bates YES, Mr. Glancy YES and Mr. Piros YES.

JULY 17, 2006

YES 3

NAY 0

Motion Carried.

Mr. Bates said the last mosquito spraying will take place tonight.

Mr. Bates informed the public that the Lakeshore Development Sewer Project meeting will be at the Trumbull County Agricultural Building on Wednesday, August 09th at 7 PM.

172-06 Motion by Mr. Bates, seconded by Mr. Glancy to go into executive session with Police Chief Sayers to discuss possible employee discipline at 8:30 PM.

Vote on Motion: Mr. Bates YES, Mr. Glancy YES and Mr. Piros YES.

YES 3

NAY 0

Motion Carried.

Trustees returned at 9:10 PM with no action taken.

173-06 Motion by Mr. Piros, seconded by Mr. Glancy to adjourn the meeting.

Vote on Motion: Mr. Bates YES, Mr. Glancy YES and Mr. Piros YES.

YES 3

NAY 0

Motion Carried.

By Motion Adjourned,

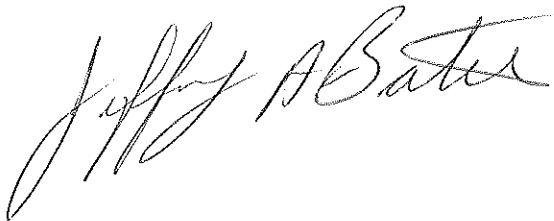

**WORK SESSION ON BUDGET
TUESDAY, JULY 25, 2006 AT 8 AM
ADMINISTRATION BUILDING**

Present: Trustees Jeff Bates, Mike Piros and Bill Glancy
Fiscal Officer Martha Urchek

Martha handed out a copy of the Appropriation Status Report dated July 24, 2006 to all trustees.

After reviewing each fund carefully, trustees asked Martha to call Frank Parke in for a meeting on the cemetery funds.

If money needs to be transferred from the General Fund to the Cemetery Fund and Zoning, it will be placed on the agenda for August 7th meeting at 9 AM. Mr. Piros said we are obligated to take care of the cemetery.

A budget work session with Fire Chief McKenzie will be scheduled at the August 7th meeting to review fire district funds.

Other items discussed were:

- cell phone usage
- custodial contract
- cemetery letter to Cortland City
- health care insurance letter for quotes
- easement at Shortreed's property

Mr. Piros asked Martha to put the following on the agenda for the next meeting:

- Work session with Fire Chief McKenzie
- Work session with Park Board
- Cell phone policy
- Howland Printing – printing of 2800 flyers – cost of \$598
- Postal Mail Sort – mailing 2251 flyers out to registered voters only – cost of \$548.35
- Approve construction of East Central Bazetta sanitary sewer improvement by Trumbull County Commissioners on July 19th.
- Public hearing for Lakeshore Drive sanitary sewer improvement on Wednesday, August 9th at 7 PM at the Trumbull County Agriculture and Family Education Center, 520 West Main Street in Cortland.
- Electric – Township Park gazebo
- Timber Creek street lighting project
- Custodial contract

Meeting adjourned at 8:40 AM



**BAZETTA TOWNSHIP TRUSTEES REGULAR MEETING
MONDAY, AUGUST 07, 2006 AT 9:00 AM**

Present: Jeff Bates, Mike Piros and Bill Glancy.

Old Business:

Mr. Piros received a call from a resident regarding the railroad crossing at Route 305. The trustees wrote a letter on June 20th to Norfolk-Southern Railroad Company regarding concerns on three crossings; namely Route 305, Phillips Rice Road and Bazetta Road. We are waiting for a follow-up.

Mr. Glancy reported he attended a meeting at Howland on the consolidation of fire services from five townships. The feasibility study cost is between \$7,000 and \$8,000 per township. He felt this would have no advantage to our township. He also stated the Fire Chiefs will go over the areas to be evaluated such as dispatch, emergency/disaster management and community demographics. He said there were 15 people in attendance and 7 were from Howland.

Mr. Piros interjected that the distribution is not fair. Some townships have a higher population and some have bigger budgets.

Mr. Bates stated he would like to have a meeting with our BWC Employer Service Representative and asked Martha to set up a date and time to discuss our 10-Step Plan of Action which is due by September 30th.

He is signing up for a training class in September with BWC for a 6-hour credit.

Mr. Bates stated he and the other two trustees met with our representative from Alltel and Mr. Glancy and Mr. Piros will be taken off the national plan with the township, which will reduce the monthly cost. Mr. Bates said Robyn Metheny, Administrative Secretary, and Jerry Mauger, Zoning Inspector, will turn in their phones as well. One of the items to consider in a future work session will be to put restrictions on some employee's phones.

Mr. Bud Bowen, State Route 5, made a comment that he thought the township cell phones were issued only for township business.

Mr. Piros said we have a cell phone policy and the trustees are working with our legal counsel on this and will look at having it completed at the next meeting.

Public Participation:

Cheryl Tennant, Perkins-Jones Road, read the cell phone policy, which was dated March 07, 2005 and suggested we add to the present policy and define casual use and not pay Mr. Finamore.

AUGUST 07, 2006

She also asked how the employees are going to pay back to the township.

Mr. Piros said he looked at his cell phone statement and said he had minimum personal calls and needs his cell phone to call residents who have problems and he has made several long distance phone calls to Akron regarding negotiations. Cheryl said she didn't have any problem with his bill.

At this time she asked to have the minutes from the last meeting corrected. On page 135 she would like the seventh paragraph, fourth sentence corrected to read: She also wanted to know who voted to have the cell phones as the trustees did not have cell phones when she was here. What year did they get them? Mr. Glancy said everyone has a cell phone.

Mr. Bates stated that the trustees decided to pay 10% of their health care starting August 01, 2006, which would be deducted from their August 31, 2006 paycheck. They are discussing the same 10% for all non-bargaining personnel.

174-06 Motion by Mr. Bates, seconded by Mr. Glancy that the trustees pay 10% of their health care starting August 01, 2006, which will be deducted from their August 31, 2006 paycheck. Vote on Motion: Mr. Bates YES, Mr. Glancy YES and Mr. Piros YES.

YES 3

NAY 0

Motion Carried.

Janet Perhach, Northview Drive, asked if any other employees pay for their insurance. Mr. Piros answered that due to the union contracts, Fire has a \$1,100 cap and the Police have a \$1,000. Martha stated that not all fire and police employees pay the same amount as the family coverage is more expensive then the single coverage. Mr. Piros felt that a straight percentage would be a fair amount for all employees to pay.

William Calhoun, 1089 Prince Drive, had some concerns on the easement on Prince Drive that needs cleaned. His garage gets flooded which make his basement wet. The tile hasn't been cleaned for 20-25 years and asked to have it cleaned. A 12" pipe was put in and a 16" pipe should have been put in. Mr. Parke said he was there and has contacted Soil and Water.

Mr. Glancy asked if people are dumping something in the ditch and Mr. Calhoun said that could be. Mr. Glancy asked if this was on private property and the answer was yes. Mr. Parke says the catch basin overflows and floods the road. Mr. Parke asked that each property owner sign an easement paper.

AUGUST 07, 2006

Mr. Piros authorized Mr. Parke to proceed with the easement form and bring it back to us. Mr. Piros also authorized him to do the necessary work.

Mr. Glancy told both Mr. Parke and Mr. Calhoun that he will help in getting the easement papers signed by the property owners.

Ken Flack, State Route 5, has concerns about the low-hanging tree branch at the intersection of Cadwallader-Sonk and McCleary Jacoby Road that is obstructing the view of trucks and other large vehicles.

Mr. Piros said this is out of our jurisdiction and we had our legal counsel write the homeowners a letter some time ago. He will have this put on the agenda for the next meeting, as Mr. Finamore will be present.

Mr. Flack also mentioned a bush at the corner of State Route 46, McCleary Jacoby Road and Cadwallader-Sonk Roads. The bush is so overgrown that his mirrors have been damaged. Mr. Piros said if this is in the right-of-way, we can trim them.

175-06 Motion by Mr. Glancy, seconded by Mr. Piros to approve the minutes of the July 17th meeting with the requested changes made by Mrs. Tennant.

Vote on Motion: Mr. Bates YES, Mr. Glancy YES and Mr. Piros YES.

YES 3

NAY 0

Motion Carried.

The following correspondence was read by Fiscal Officer Martha Urchek:

1. Letter from the Trumbull County Board of Elections for contact list request for November Election.
2. Emailed information to local newspapers on minutes of meetings and up coming meetings.
3. Letter from the Trumbull County Sanitary Engineer's Office on a public hearing to be held on August 09th at 7 PM at the Agriculture and Family Education Center on West Main Street for the Lakeshore Drive Sewer Improvement.
4. Letter from the Trumbull County Commissioners on the approval of construction of the East Central Bazetta Sanitary Sewer Improvement Project on July 19, 2006.

AUGUST 07, 2006

5. Sent letter to the Trumbull County Board of Elections advising them they could use our hall for any meetings they need to have regarding the ID requirements for the November election.
6. Invitation from Ivy Hills on their second annual community block watch picnic on August 20th.
7. Letter from Mark Thomas Ford regarding a survey that will be sent.
8. Received the new ambulance on July 20th. I called OTARMA to insure the new ambulance.
9. Received letter from Dan Polivka, Trumbull County Commissioner, who is forming an Advisory & Strategic Planning Committee and asked for any volunteers. Mike Piros asked John Lacusky to serve on this committee and he accepted.
10. Letter from Earl Casterline who requested to be buried at the Casterline Cemetery.
11. Letter/invitation from SCOPE on their annual Society of Honors Luncheon to be held on September 12th.
12. Invitation from Kent Bicentennial Project on their parade in Kent on September 09th.
13. Invitation from Trumbull Memorial Hospital Center for Emergency Medicine on Thursday, August 03rd.
14. Letter from Attorney Mark Finamore on the Release of Nuisance Abatement Lien Tax Assessment on the property located at 941 and 947 Johnson Plank Road.
15. Email from Darlene St. George on information for storm water utility.
16. Letter from BWC on premium discount program plus-severity and frequency reduction.
17. Email from Mahoning Valley Safety Council on transitional work grants and a BWC Services Showcase meeting to be held on August 23rd.
18. Letter from the Trumbull County Engineer's Office informing us of the Warren-Meadville Road closing being extended until Tuesday, September 05th.
19. State Capital Improvement Program (SCIP) and Local Transportation Improvement Program (LTIP) for Mahoning and Trumbull Counties are sponsoring workshops on August 16th at Howland and on August 17th at Austintown.

AUGUST 07, 2006

20. Meeting agenda from Trumbull County Board of Health for August 09th and minutes from their June 21st meeting.
21. Received a letter from the Trumbull County Sanitary Engineer's Department on a letter written to Representative Tim Ryan on financial assistance for Lakeshore Drive Sanitary Sewer Improvements Projects.
22. Motion to discuss a letter to be mailed out to health care providers for quotes and to place an ad in the local newspaper.

176-06 Motion by Mr. Glancy, seconded by Mr. Piros to approve purchase orders.
Vote on Motion: Mr. Bates YES, Mr. Glancy YES and Mr. Piros YES.

YES 3

NAY 0

Motion Carried.

177-06 Motion by Mr. Piros, seconded by Mr. Glancy to approve payment of bills.
Vote on Motion: Mr. Bates YES, Mr. Glancy YES and Mr. Piros YES.

YES 3

NAY 0

Motion Carried.

Road Superintendent Parke:

Mr. Parke submitted his monthly report for July, 2006. He thanked the trustees for allowing his department to attend the trench excavating class at Howland. It was very interesting and the instructors were well trained.

Kris Parke contacted Mike Sliwinski on Issue II money. Kris will attend the August 16th District 6 Public Works Integrating Committee Workshop at Howland. Mr. Parke said monies available is higher this year of which 31% is our local share. He doesn't want to combine Durst Clagg and Howland Wilson in fear that if rejected, both would be rejected, whereas if he submits individually, maybe we will get one or both.

178-06 Motion by Mr. Piros, seconded by Mr. Glancy to allocate 31% of next years local government share of Issue II monies.
Vote on Motion: Mr. Bates YES, Mr. Glancy YES and Mr. Piros YES.

AUGUST 07, 2006

YES 3

NAY 0

Motion Carried.

Mr. Parke went on to say his department is mowing second cut of roadsides, has several tile jobs on schedule and needs to trim trees in the cemetery. It will take two guys two weeks to trim the cemetery trees. He thought the grass cutting would let up, but it hasn't.

Mr. Piros asked how many tile jobs and the reply was two plus we are mowing and patching. After much discussion on hiring back part-time help, Mr. Piros set up the following work sessions at the administration office with the trustees:

Monday, August 14th at 7:30 PM with the Fiscal Officer
Tuesday, August 15th at 8:00 AM with the Road Superintendent
Tuesday, August 15th at 9:00 AM with the Fire Chief
Monday, August 21st at 8:30 PM with the Park Board
Tuesday, August 22nd at 7:30 PM with the Police Chief

Janet Perhach asked if the work sessions were open to the public and Mr. Glancy said yes.

Mr. Bates asked Martha to advertise the work sessions.

Mr. Bates said he had a conversation with Jack Governor, Park Groundskeeper, who had concerns that the park is looking bad. The pavilion near the Imagination Station is fading, and baseball diamond in-fields need mowed. Mr. Bates authorized two weeks of 40 hours each week weather permitting for Mr. Governor to do the needed work at the park.

Mr. Bud Bowen, State Route 5, asked if we are short of money, how you can find money for the park and the road department doesn't have any money. General public doesn't get any and the park gets everything. You shut the road department down all the time. He also asked how much money we spent on the gazebo at the park. Mr. Piros stated the gazebo was purchased with inheritance money, which was also divided up amongst the other departments. Mr. Piros further explained that money for the groundskeeper's salary was allocated at the beginning of the year and all the money hasn't been used.

At 9:45 AM, Mr. Bates had to leave for work and turned the chair over to Mr. Piros.

Mr. Bud Bowen, State Route 5, mentioned to Mr. Bates that every morning meeting he has to leave early to go to work. He said when he ran for office of Trustee, he knew he would have obligations for meetings. Mr. Bates stated that circumstances beyond his control that after being elected, he had to find another job and that this is personal. Mr. Bates said the evening meetings

AUGUST 07, 2006

are fine with him. Mr. Bowen said maybe we should go back to the evening meetings. Mr. Bates said that would be fine with him

Mr. Piros said that the majority of the Trustees, which consists of two, can vote on issues.

Mr. Bates said we may go back to evening meeting, which we will be reviewed at the beginning of next year.

Police Chief Sayers:

Chief Sayers asked the trustees to accept a donation of three used Mobile Data Terminals (MDT) from the Akron Police Department.

179-06 Motion by Mr. Piros, seconded by Mr. Glancy to accept the donation of three used Mobile Data Terminals (MDT) from the Akron Police Department.

Vote on Motion: Mr. Glancy YES and Mr. Piros YES.

YES 2

NAY 0

Motion Carried.

Mr. Glancy stated the continuing professional training for police officers will be discussed at the work session on August 22nd.

Mr. Glancy asked about the speed radar machine and suggested to Chief Sayers that he would like "live" police officers during the school hours. Chief Sayers will comply with this request.

Mr. Bud Bowen, State Route 5, stated he was told there are always two officers on duty at all times. Mr. Glancy said this is the number one priority for the work session.

Ken Flack, State Route 5, asked Police Sayers how many police cars the township has and the reply was nine. Mr. Flack said one officer working when we have nine cars is embarrassing. Mr. Glancy said that is a target for violence.

Fire Chief McKenzie:

Chief McKenzie had nothing to report.

Martha asked if he would talk about the recent Ohio Fire Chief's conference he attended.

AUGUST 07, 2006

Chief McKenzie said he was elected 2nd Vice President of the Ohio Fire Chiefs Association and in 2009 he will be President. The trustees congratulated him.

Mr. Glancy also pointed out that Chief McKenzie was in Lake County on July 28th regarding the recent heavy rains there.

Zoning Inspector Mauger:

Mr. Mauger reported he went to Chris Medzie's property at 3723 Bazetta Road. All the cars, tires and rims have been removed and nothing to cause a nuisance.

He received a complaint about the vacant lot at 2962 Beaver Trail and reported the demolition of the structure at 3054 North Park is waiting for Ohio Edison to disconnect power.

Mr. Mauger stated Wal-Mart construction bids are going out the middle of this month and groundbreaking could be started by the end of September and negotiations with ODOT over a traffic light at the site are continuing. Mr. Parke said the intersection traffic light has gone from 7 to 4 and back to 7 lights.

Mr. Mauger also said several people have expressed an interest in purchasing the chain's present store as a possible warehouse. Also, the strip plaza at the entrance of the new Wal-Mart has been sold and the new owner is looking for tenants.

Mr. Mauger said he will contact Brian Prunty of Soil and Water to contact Nancy White, Wilshire Drive, on her water problem.

Mr. Piros asked Mr. Mauger to turn his cell phone in since he doesn't use it.

Safety Committee:

Chief Sayers had nothing to report.

180-06 Motion by Mr. Glancy, seconded by Mr. Piros to change the September 04th meeting due to the holiday to Tuesday, September 05th at 9:00 AM.

Vote on Motion: Mr. Glancy YES and Mr. Piros YES.

YES 2

NAY 0

Motion Carried.

AUGUST 07, 2006

Mr. Piros noted that the park will close on November 01st to coincide with the ODNR closing of the State Park.

181-06 Motion by Mr. Glancy, seconded by Mr. Piros to have Howland Printing to print 2,800 fall flyers at a cost of \$598.

Vote on Motion: Mr. Glancy YES and Mr. Piros YES.

YES 2

NAY 0

Motion Carried.

182-06 Motion by Mr. Glancy, seconded Mr. Piros to pay \$548.35 to Postal Mail Sort for the mailing of 2,251 fall flyers to registered voters only.

Vote on Motion: Mr. Glancy YES and Mr. Piros YES.

YES 2

NAY 0

Motion Carried.

Mr. Piros will forward all the information for the electric at the township park gazebo to Dave Rockman, who is doing the architectural engineering at the gazebo for review.

There was much discussion on the Timber Creek street lighting project. Mr. Piros read two quotes he received for the installation of 13 streetlights. One was from Genesis Electric Corporation of Akron for \$7,250 and the other was from Valley Electrical Consolidated, Inc. of Girard for \$16,400. Mr. Piros will contact both vendors to come to the next meeting to make sure both companies understand the project that involves the installation of 13 streetlights. Mr. Piros said the big discrepancy makes one wonder if they understand the project. Mr. Piros went on to say that Ohio Edison's quote for hook-up is \$11,473.74 for 13 streetlights. The township will pay this upfront and the money will be recouped over a two-year period.

Mr. Parke asked if Steve Provita of Ty-Xcavating sent in a quote and Martha said these are the only two she received. Mr. Parke will contact Mr. Provita.

183-06 Motion by Mr. Piros, seconded by Mr. Glancy to table this discussion.

Vote on Motion: Mr. Glancy YES and Mr. Piros YES.

YES 2

NAY 0

Motion Carried.

AUGUST 07, 2006

The custodial contract was tabled and will be put on the agenda for the next meeting.

Due to the recent request from the Board of Elections as to who will be unlocking and locking the doors at the administration building on Election Day, November 07th, Mr. Piros said he would unlock and lock the doors.

184-06 Motion by Mr. Glancy, seconded by Mr. Piros to authorize the Fiscal Officer to transfer the following within the cemetery funds:

From 05-A-02 Salaries (Burials/Sexton) to 05-A-03 Employers Retirement Contribution \$1,000
From 05-A-02A Salaries (Clerical) to 05-A-12 Other Expenses (Utilities) \$500
From 10-A-01B Fire (Salary Mechanic) to 10-A-02 Fire (Employer's Retirement Contrib.) \$200
Vote on Motion: Mr. Glancy YES and Mr. Piros YES.

YES 2

NAY 0

Motion Carried.

Mr. Piros reminded everyone of the Lakeshore Development Sewer Project meeting to be held at the Trumbull County Agricultural Building on Wednesday, August 09th at 7:00 PM.

Mr. Piros also stated that the Trumbull County Commissioners approved the construction of the East Central Bazetta Sanitary Sewer Improvement on July 19th.

Janet Perhach asked when they would start. Mr. Piros said after the approval of the construction bid, the completion time period is 180 days or 6 months and this project could start sometime in the fall.

Mr. Piros went on to explain the Issue II criteria for low income. The Federal Poverty Level for combined income has to be \$525 or lower.

Mr. Glancy asked Mr. Parke about sewers on State Route 5. Mr. Parke said they go up to the BP Gas Station. Mr. Glancy said the BP Station has been sold to Circle K. Mr. Glancy asked about the Lauer property which was recently annexed to the City of Cortland and Mr. Mauger said it is near Garden Brook not near the BP Station.

Mr. Bud Bowen, State Route 5, asked about the sewer from Millennium Boulevard to Burnett Drive. Mr. Piros stated the Sidley property was to be purchased for industrial, but the buyers felt the owners wanted too much money and they backed out. Once the property is sold, dollars become available through the Ohio Department of Development but can't use the money for anticipated businesses. The Ohio Department of Development only will give grant money to

AUGUST 07, 2006

industrial properties with access to major roads and rail. To use the grant money, we need a buyer.

Mr. Piros received a call from Greenwood regarding the Sidley property so there is still interest out there.

Mr. Glancy said that Diane Sauer's Chevrolet was looking at this property at one time, but General Motors has a regulation that dealerships can only be within so many miles of each other.

Mr. Parke made a comment that Harmon Motors Car Lot is empty and for sale along with the batting cages on State Route 5.

Mr. Glancy made a comment he can't convince the Lodge Committee that cabins make more sense than a lodge. They have spent some \$80,000 for a feasibility study. Mr. Piros agreed that cabins would be better for the community.

Mr. Glancy said he goes to Pymatuning Lake and the cabins there are always full at a low cost and the people are out shopping in the area for food, gas, etc. Cabins here would be a big boost to the State Park and our community.

Mr. Bud Bowen, State Route 5, said look at the fairgrounds. Mr. Piros said don't go there as that is a sore subject with me.

185-06 Motion by Mr. Piros, seconded by Mr. Glancy to adjourn the meeting at 10:30 AM.
Vote on Motion: Mr. Glancy YES and Mr. Piros YES.

YES 2

NAY 0

Motion Carried.

By Motion Adjourned.

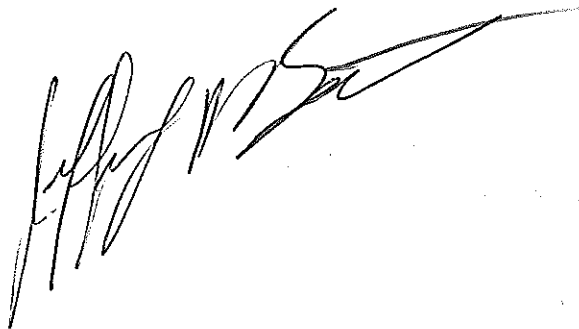
A large, stylized handwritten signature in black ink, likely belonging to Mr. Piros, is written over the bottom right portion of the page. The signature is cursive and somewhat illegible due to its speed and style.

**WORK SESSION WITH THE FIRE DEPARTMENT
AUGUST 14, 2006 AT 9:00 AM
HELD AT THE TOWNSHIP ADMINISTRATION BUILDING**

Present: Jeff Bates, Mike Piros, Bill Glancy, Martha Urchek, Clyde McKenzie, Mike Mannella, Tom Rink, Steve and Janet Perhach.

Discussion on:

- Dropping part timers to working one shift. Clyde explained 4-4-3 shifts with full-time and work part-time in 3rd shift. Part-time personnel can be called for vacation, CT, and personal time replacements. Full-time personnel can only replace co-workers who report off sick.
- Placing a renewal or re-evaluate levy for the May, 2007 primary.
- Sending letter to L&D Medical notifying them within 60 days we are not renewing our contract with them. We will enter into a new cost of recovery contract with Ohio Billing for our EMS services reimbursement money.
- Tom Rink explained we will benefit more from the new billing company such as auto accidents, auto fires, and auto rescues. Again, there will be no fee to Bazetta residents.
- Chief McKenzie gave the Trustees his opinion on the EMS Regional Fire District to stay in the ballgame for right now.
- Mike Mannella gave a status report on replacing the doors and windows at Station 13.
- The firemen will start painting the station once the replacement of the windows and doors are in.
- Martha will need to set up two separate funds for Ohio Billing.

Meeting adjourned at 9:45 AM.

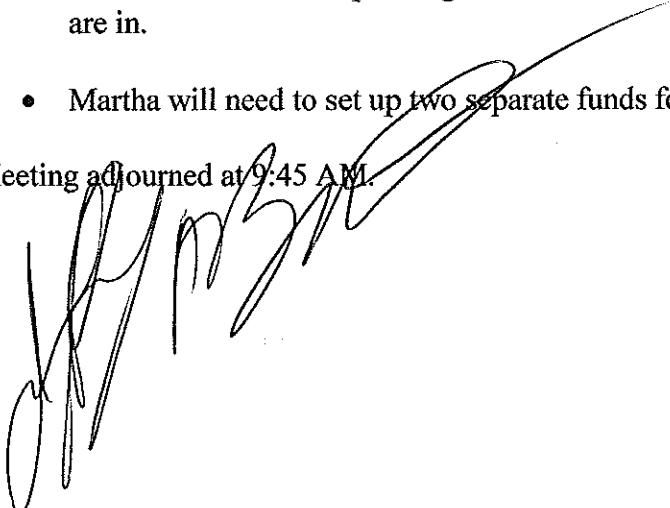

**BAZETTA TOWNSHIP TRUSTEES REGULAR MEETING
MONDAY, AUGUST 21, 2006 AT 7:00 PM**

Present: Jeff Bates, Mike Piros, Bill Glancy and Legal Counsel Mark Finamore

Old Business:

Mr. Piros stated he met with a resident on Lakeshore Drive about a water problem. Mr. Smith from the Trumbull County Engineer's Office was called out and will do a study of the problem.

Mr. Piros received the first draft of the township newsletter from Howland Printing and after making some modifications the newsletter should go out to all registered voters sometime during the first week of September.

Mr. Piros met with residents in Timber Creek regarding a water problem

This board has many sewer projects going on. The Trumbull County Commissioners approved the East Side Sewer Project and the West Side Sewer Project is in progress. He stressed these sewer projects are county projects not the township. The county has to go for any grant money. He researched a total of 95 grants trying to get some assistance for our residents and found maybe one that could apply, but it would be a short term loan at 4% and most residents couldn't afford it. That is why the county went for a bond for 20 years. He will turn this information over to Gary Newbrough. Low income and EPA grants do not apply. We would like to go on record that this board is actively involved with sewer problems.

Mr. Glancy went with Mr. Parke to Prince Drive regarding some draining and easement problems.

Mr. Glancy along with the other two trustees attended work sessions with the road and fire departments and attended a 5-hour negotiation meeting with the road department.

Mr. Bates and Martha will meet on September 06th with Mary Betts from the BWC on our 10-Step Program that is due on September 30th.

Mr. Bates expressed his gratitude to all the department heads and their employees in the reduction of BWC claims as we received over \$23,000 credit on our premium for the last half of 2005.

Public Participation:

August Fauvie, 2491 Andrews Drive, said his development has about 40 homes in it and wants to know what the trustees are going to do about sewer lines at the street. The sewer lines are in, but we still have septic systems. Mr. Bates said that he personally took a sewer petition to the Trumbull County Engineer's Office and is waiting for a response from Mr. Newbrough.

AUGUST 21, 2006

Mr. Fauvie said the tile was put in some 20 years ago. Mr. Piros said we have no jurisdiction for sewer lines.

Mr. Finamore, Legal Counsel, stated sewer lines do not belong to the township they belong to the Trumbull County Commissioners, Sanitary Engineer and the Board of Health.

Mr. Glancy said a few years back we stepped over and did help out the residents there, but we do not maintain sewers.

Mr. Bates said the process takes about two years after the petition is received.

Mr. Fauvie said the sewers were put in by Andy Yount. His house is plumbed for city sewers. Mr. Piros said the Trumbull County Sanitary Engineer has to do a study.

Art Kreller, 2366 Andrews Drive, asked how the procedure works. Mr. Piros explained a petition has to be submitted with at least 80% of interested residents for the Commissioners to approve the engineering study. Then a public hearing is held letting the residents know the cost and how it can be funded. The residents have a waive period and if the majority say yes, then the project is awarded for a construction bid. It does take 1 ½ to 2 years after the petition is submitted.

He agreed with Mr. Glancy that we did try to unplug the sewer on Andrews Drive a few years ago, but then Mr. Parke had to call the county out and we paid the county.

Mr. Finamore said it is a dedicated sewer and belongs to the county. Draining ditch belongs to the township and anything under the road belongs to the township as we are obligated to maintain the township roads.

Mr. Kreller went into the woods when the loggers were cutting down trees by the railroad tracks and found 10' square with a manhole cover in the woods with the words "sanitary sewer" written on top of the manhole cover. He called the county and they said it was a "dummy", the township said it was not.

Carolyn Wolanzyk, 2460 Andrews Drive, asked if sewers are put in, then where does the waste go? Mr. Piros said there would have to be a lift pump station and treatment plant.

Mr. Glancy said there is a waste water treatment plant on the south side of Warren. The engineering study will determine if one is necessary and where it will go. Mr. Glancy said Lakeshore Allotment will have one and will be put at the end of Lakeshore Drive.

Mr. Finamore said the lift station pump will send it to the plant for treatment.

AUGUST 21, 2006

Mr. Kreller asked if it would be possible to tie in with the new Super Wal-Mart and Mr. Finamore said that could be a possibility if Wal-Mart would pay for it.

Mr. Fauvie stated the blacktop has ¼" cracks through it and asked if it could be filled in so the cracks don't erode over the winter. The board will point this out to Mr. Parke as we could use tire grant money for that project.

Mr. Kreller asked about the driveway entrances chipping away.

Mr. Glancy said it was called to the board's attention about the gas well trucks, but the fire trucks and school buses weigh the same.

Mary Beth Hayer, 2962 Ivy Circle, asked about dog control. Mr. Finamore said dogs should be on a leash when not on their property and under control while on their property. She asked about cats running loose. Mr. Finamore said nothing under the law says anything about cats. If there is an issue, contact the neighbor. Mr. Sayers said if there are any problems with animals, call the police department. Mary Beth said she lives in a private community and Mr. Sayers stated it is still in the township.

Carolyn Wolanzyk, Andrews Drive, asked about trapping in the woods behind her. Mr. Bates said hunters are required to get permission to hunt on private property and the township has no jurisdiction on private property and she should call the State Park for the game warden's phone number. He thought it was 1-800-POACHER.

Mrs. Fauvie, Andrews Drive, said Andy and Margaret Yount wouldn't let anyone on their property.

186-06 Motion by Mr. Bates, seconded by Mr. Piros to authorize the Fiscal Officer to transfer money within the following funds:

01-C-03 Fire Equipment Utilities to 01-C-07 Repairs to cover the ambulance \$3,150.00
 01-A-03 Administration (Travel & Expenses) to 01-F-01 Salaries-Mechanic (Park) \$1,500.00
 10-A-01A Fire (Part-Time Salaries) to 10-A-03 Fire (BWC) \$13,912.55
 10-A-01A Fire (Part-Time Salaries) to 10-A-01 Fire (Full-Time Salaries) \$40,000.00
 10-A-01A Fire (PT Salaries) to 10-A-02 Fire (Employer's Retirement Contribution) \$20,000

Vote on Motion: Mr. Bates YES, Mr. Glancy YES and Mr. Piros YES.

YES 3

NAY 0

Motion Carried.

AUGUST 21, 2006

187-06 Motion by Mr. Bates, seconded by Mr. Glancy to authorize the Fiscal Officer to request An Amended Certificate of Estimated Resources from the Trumbull County Auditor for the following:

To increase Zoning Fund 13 \$3,310.26
To be appropriated to 13-A-01 Salaries

To increase Cemetery Fund 5 \$22,865.00
To be appropriated to 05-A-01 Salaries (Mowing) \$15,000.00
To be appropriated to 05-A-03 Employer's Retirement \$7,865.99

Vote on Motion: Mr. Bates YES, Mr. Glancy YES and Mr. Piros YES.

YES 3

NAY 0

Motion Carried.

188-06 Motion by Mr. Glancy, seconded by Mr. Piros to approve the minutes of the August 07th meeting.

Vote on Motion: Mr. Bates YES, Mr. Glancy YES and Mr. Piros YES.

YES 3

NAY 0

Motion Carried.

The following correspondence was read by Fiscal Officer Martha Urchek:

1. Received certificate showing increase on the new 2006 Ford E-350 Ambulance and deleting the 1996 Ford Wheelcoach Ambulance.
2. Received a fax from Varnum Attorney's At Law on the cable bill (H-5252).
3. Emailed local newspapers meeting minutes and upcoming work sessions and meetings.
4. Received a letter from Concerned People of Bazetta regarding help with grants for sewers.
5. Received a letter from Ambrosy and Fredericka, Attorney's for Four Seasons Car Wash regarding the traffic situation when the new Super Wal-Mart is built.
6. Received a copy of the letter from Vienna Township Trustees that they are no longer participants in the Fire' EMS Consolidation talks with Howland and other townships.

AUGUST 21, 2006

7. Received an invitation and biography from David M. DeChristofaro for a Columbus Day Campaign Dinner as he is running for Trumbull County Engineer in 2008.
8. Received information on SERB Academy 2006 and SERB Ohio Public Sector Developing Labor Law Seminars.
9. Received our State of Ohio Cooperative Purchasing Program Certificate of Membership for August 2006 through August 2007. A copy of this was given to the department heads.

189-06 Motion by Mr. Piros, seconded by Mr. Glancy to approve purchase orders.
Vote on Motion: Mr. Bates YES, Mr. Glancy YES and Mr. Piros YES.

YES 3
NAY 0
Motion Carried.

190-06 Motion by Mr. Bates, seconded by Mr. Glancy to authorize Mr. Piros to write a letter to Aaron Hanson, Eagle Scout for Troop 101, on the completion of the West Bazetta Cemetery signs. He also asked the public to go and look at the signs and bench Aaron did. He did an outstanding job.
Vote on Motion: Mr. Bates YES, Mr. Glancy YES and Mr. Piros YES.

YES 3
NAY 0
Motion Carried.

191-06 Motion by Mr. Piros, seconded by Mr. Bates to approve payment of bills.
Vote on Motion: Mr. Bates YES, Mr. Glancy YES and Mr. Piros YES.

YES 3
NAY 0
Motion Carried.

Mr. Glancy mentioned the Lakeview Baseball 8-10 years old won the state championship. The board congratulated them for a fine job.

Police Chief Sayers:

Chief Sayers requested to go into executive session to discuss possible employee discipline. Mr. Piros suggested we do this at the end of the meeting and it was agreed upon by Chief Sayers.

AUGUST 21, 2006

Fire Chief McKenzie:

Chief McKenzie had nothing to report.

Road Superintendent Parke:

Mr. Parke was absent.

Zoning Inspector Mauger:

Mr. Mauger reported he contacted Brian Prunty of the Soil and Water on the water problem on Wilshire Drive. Brian will contact Ted David Construction to correct the situation.

Mr. Mauger met with new representative, Justin Bechtel, Trumbull County Board of Health, on properties at 460 and 380 State Route 305. Mr. Mauger has a letter to go to the Health Department on the 380 State Route 305 property.

He said the power has been disconnected at 3054 North Park and the contractor will start demolishing the structure sometime next week.

Mr. Glancy said on the west side of Bazetta there are 17 deserted houses. Mrs. Wolonyzk asked if it was due to the cost of new septic systems. Mr. Glancy said it is because of foreclosures and not septic tanks. He knew of two near him; one house was foreclosed on because of gambling and the other one because of a divorce.

Mr. Piros said we are not the only community.

Mr. Glancy said it's too bad these houses couldn't be given to the homeless.

Mrs. Wolonyzk asked how are these taken care of. Mr. Glancy said through sheriff sales. Mr. Glancy said there is a backlog of two years for sheriff sales of houses in Trumbull County. Mr. Bates said you could live in your house for two years.

Mr. Glancy said there are over 900 deserted homes in Trumbull County.

Mr. Finamore stated the mortgage companies will pay the interest so not to have to take these houses back.

Mr. Piros said these abandoned homes have mold all through it because the electric is turned off, therefore, the sump pumps don't work and the basements fill up with water.

AUGUST 21, 2006

Mr. Mauger said most of the mortgage companies are out west and the mortgage companies have been sold 3 or 4 times.

Safety Committee:

Chief Sayers had nothing to report.

Mr. Bates mentioned that our transitional work policy and our attendance at both the Drug Free Work Place Seminars and attendance at the monthly national safety luncheons/meetings had a tremendous impact on our BWC frequency and severity reduction. Mr. Bates also mentioned that all employees who were not able to attend the seminars in June, must watch the video before September 01st. Martha sent a list to all department heads.

Administration:

There was a discussion on the view obstruction at the intersection of Cadwallader-Sonk Road and McCleary Jacoby Road. A letter was sent by Mr. Finamore a few months ago to the homeowners and nothing has been done. Mr. Finamore suggested Mr. Parke to mark it off to see if it is in the roadway and if so, we can trim it.

192-06 Motion by Mr. Piros, seconded by Mr. Bates to table the above until the next meeting.
Vote on Motion: Mr. Bates YES, Mr. Glancy YES and Mr. Piros YES.

YES 3

NAY 0

Motion Carried.

193-06 Motion by Mr. Piros, seconded by Mr. Glancy to rescind resolution 150-06 dated June 23, 2006 to start taping the meetings on August 05, 2006 due to the cost of new equipment.
Vote on Motion: Mr. Bates YES, Mr. Glancy YES and Mr. Piros YES.

YES 3

NAY 0

Motion Carried.

194-06 Motion by Mr. Bates, seconded by Mr. Glancy to pay Crosby-Mook Office Equipment for the copier maintenance agreement for the police department for a cost of \$165 for one year, July 2006 to July 2007.

Vote on Motion: Mr. Bates YES, Mr. Glancy YES and Mr. Piros YES.

AUGUST 21, 2006

YES 3

NAY 0

Motion Carried.

Mr. Piros gave an update on the Timber Creek Heights Street Lighting. There was a huge discrepancy in the two quotes we received. He has called both of them and will have more information at our next meeting. The difference in the quotes was over \$9,000, it was either overbid or underbid.

Mr. Piros has talked with the architect for the electrical at the gazebo. We need to increase the transformer along State Route 305 to handle the extra lighting. The preliminary drawings are done and he will have more information at the next meeting.

195-06 Motion by Mr. Bates, seconded by Mr. Piros to accept the custodian's contract for one year, September 2006 to September 2007 for a total of \$625 per month.

Vote on Motion: Mr. Bates YES, Mr. Glancy YES and Mr. Piros YES.

YES 3

NAY 0

Motion Carried.

Mr. Finamore discussed the cell phone usage policy and will have a policy by the next meeting for the trustees to review,

196-06 Motion by Mr. Piros, seconded Mr. Glancy to pay Bureau of Workers' Compensation the second half premium of \$26,399.52.

Vote on Motion: Mr. Bates YES, Mr. Glancy YES and Mr. Piros YES.

YES 3

NAY 0

Motion Carried.

197-06 Motion by Mr. Bates, seconded by Mr. Piros to go into executive session at 7:56 PM with Police Chief Sayers to discuss possible employee discipline.

Vote on Motion: Mr. Bates YES, Mr. Glancy YES and Mr. Piros YES.

YES 3

NAY 0

Motion Carried.

Trustees returned to regular session at 8:15 PM with no action taken.

AUGUST 21, 2006

198-06 Motion by Mr. Piros, seconded by Mr. Glancy to adjourn the meeting at 8:15 PM.

Vote on Motion: Mr. Bates YES, Mr. Glancy YES and Mr. Piros YES.

YES 3

NAY 0

Motion Carried.

By Motion Adjourned.

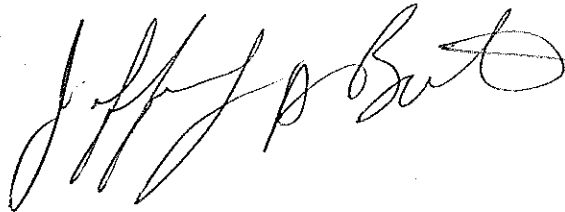
A handwritten signature in cursive script, appearing to read "Jeff P. Bates". The signature is written in black ink and is positioned to the right of the text "By Motion Adjourned."

**WORK SESSION WITH THE TOWNSHIP PARK BOARD
AUGUST 21, 2006 AT 8:30 PM
HELD AT THE TOWNSHIP ADMINISTRATION BUILDING**

Present: Jeff Bates, Mike Piros, Bill Glancy, Martha Urchek and Park Board Member, Karen Margala.

Martha passed out the Appropriation Status for the park dated August 21, 2006 which shows Appropriated Amount of Funds and Encumbered amount and Unencumbered balance and year-to-date spent.

Mr. Piros stated that if the money is not spent, the money will not carry over for next year. The total amount in the Park Fund not spent is approximately \$14,000.

Mr. Piros gave an update on the electric for the gazebo. The architect has the preliminary drawings and will give us an estimate to do the job right as we will need a new transformer to handle the additional lights. Our present one doesn't meet code.

Mr. Piros stated he has taken many complaints on the road in the park and in talking with Mr. Parke, the county is to give us a quote to bring out a grader to level it off.

Mr. Piros asked Karen if the committee had anything to report and she said they haven't had a meeting so there was nothing to report.

The board would like to see priority one to be the landscaping, second priority to be the roadway and the third priority to be the electric.

The meeting was adjourned at 8:45 PM.

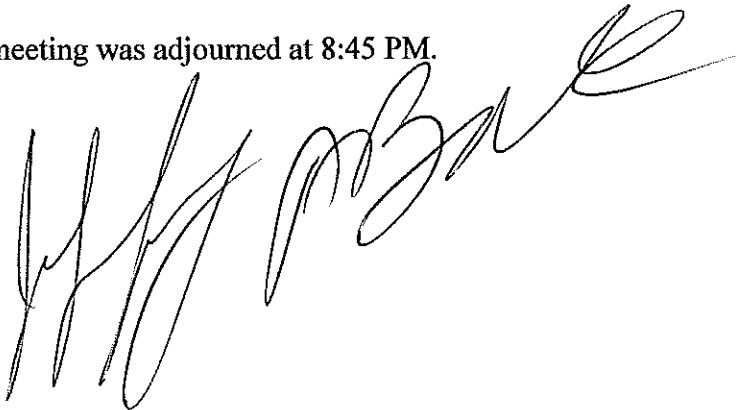
A large, stylized handwritten signature in black ink, likely belonging to Jeff Bates, is written across the bottom of the page. The signature is cursive and somewhat illegible due to its speed and style.

**Bazetta Township Trustees Work Session
Police Chief**

Minutes

Date: 8/22/2006
 Time: 7:30 pm
 Place: Township Administration Building
 Present: Michael Piros, William Glancy, Jeffery Bates, Mr. & Mrs. Perhach,
 Marley from Tribune

Discussion:

- I Police Budget (regards to personnel)**
 - a. Manpower
 - b. Short fulltime officers and part time officers
- II Reports**
 - a. Accident reports take to long to process
- III Lack of road patrols and multi officer shifts**
- IV Township Vehicle Usage (Take Home)**
 - a. What saving could there be if it they were eliminated
 - 1- One suggestion is to limit take home to only officers who live within township
 - 2. Chief will study issue and weigh advantages and disadvantages
- V Chief overworked/ and over extended**
 - a. delegate some duties
- VI Perkins stolen car incident/ unauthorized use of chiefs car**
- VII Set goals for chief to accomplish by December 1st 2006**
 - a. Hire/replace one fulltime officer in 30days
 - b. Hire part-time officers by 60days
 - c. Reinstute the Board of Officers
 - d. Increase road patrols
 - e. Increase multi officer shifts from 30% up to 65%
 - f. Delegate more administrative duties to free up chief
 - g. Increase time for accident reports to be ready within 5days
 - h. Lower officer response time to 6%
- VIII Executive Session/ Road negotiations/ Possible discipline of an employee**
 - a. 9:15pm
- IX Adjourn**



11/11/2019 10:11:11 AM

11/11/2019 10:11:11 AM

11/11/2019 10:11:11 AM

11/11/2019 10:11:11 AM

11/11/2019 10:11:11 AM

**BAZETTA TOWNSHIP TRUSTEES REGULAR MEETING
MONDAY, SEPTEMBER 05, 2006 AT 9:00 AM**

Present: Jeff Bates, Mike Piros, and Bill Glancy.

Old Business:

Mr. Piros and Mr. Glancy viewed water problems at 2950 Crown Point with Frank and Kris Parke. It was decided this was not our problem.

Mr. Piros met with Mr. Newbrough on the Janet, Lynn and Andrews Drive petition. Mr. Newbrough stated the petition should be extended to include some properties on Bazetta Road. He handed the hi-lited map over to Mr. Glancy who will see that those additional properties sign the petition. Mr. Glancy will forward the petition to Mr. Newbrough.

Mr. Piros commented on the letter he mailed to local and state officials on the article that appeared in the Tribune last week on the Lakeshore sewer project. He was very upset before Mr. Newbrough told him the article was mis-quoted in the newspaper. Mr. Newbrough is working with the ODNR on the easement issue.

Mr. Piros received a call from Marc Dann's office on his letter regarding the Tribune article on the Lakeshore sewer project.

The Eastside Sewer Project is being delayed due to Mr. Eaton's property. He was supposed to run sewer lines from Saddle Brook to Northview. This is not being done on a timely matter as the permit has expired. Mr. Newbrough wrote a letter to Mr. Eaton telling him that the county will proceed with design and construction of the needed link and Mr. Eaton will be responsible for the costs incurred.

Mr. Piros gave a report on the Timber Creek Heights street light project. He has made several phone calls to Genesis who was granted the bid and has not been able to talk to the estimator, Mike Collins. He contacted Mr. Luscher to give us a quote on this project. Mr. Piros noted that while walking around with Mr. Luscher, there are some trees planted, mulch and boulders on top where they need to get to. Mr. Luscher will give us two quotes; one without the landscaping and one with landscaping.

Mr. Glancy and the other two trustees met with the Park Board and only one member showed up.

Mr. Glancy along with Frank and Kris Parke went to look at some problems at a house in Timber Creek.

SEPTEMBER 05, 2006

Mr. Glancy reviewed the drawings for the Stonegate Plat #1 and had some concerns. He and the other two trustees as well as Frank will attend the September 12th meeting at the Planning Commission Office to voice the township's concerns. Several problems are wetlands and moving the building line up.

Frank and Mr. Mauger both said that the set back line is 40' and these plans are for 35'.

Mr. Mauger said he was told that five houses have already been sold. He informed Mr. Repphun to contact the Soil and Water on the wetlands.

Mr. Parke said Mr. Repphun called him and asked for 20 zoning permits for 20 addresses. He referred him to Mr. Mauger. Mr. Parke told him no brick mailboxes.

Mr. Glancy gave Mr. Parke two signed easements for Prince Drive. Contractors will meet with them today.

Mr. Glancy said we should sell the three cars at the garage. Mr. Sayers said he had the mechanic remove all the equipment from the police car. Mr. Glancy suggested we have a public auction. Mr. Sayers will submit a list to the trustees.

Mr. Bates reported he and Martha will meet on September 06th with our BWC specialist on our 10-Step Plan.

199-06 Motion by Mr. Glancy, seconded by Mr. Piros to approve Mr. Bates to travel to Dayton to attend a BWC training class on September 28th.

Vote on Motion: Mr. Bates YES, Mr. Glancy YES and Mr. Piros YES.

YES 3

NAY 0

Motion Carried.

Public Participation:

Janet Perhach, Northview Drive, mentioned there is a branch obstructing the view of the stop sign on Northview Drive. Mr. Bates asked Mr. Parke to look at this problem and if it is in the right-of-way, for him to remove the branch. Mr. Parke said he would get to it today or tomorrow.

Dan Wilson, North Park Avenue, asked about the status on the demolition of the structure at 3054 North Park Avenue. Mr. Mauger said he had to take a letter from the township to Mr. Zuga of Z-Tech stating he would take all the debris to a proper landfill. Mr. Zuga took this letter to the county to get the permit and he did this on Friday. Getting the power disconnected was

SEPTEMBER 05, 2006

another delay. The structure should be demolished next week.

Mr. Wilson asked Chief Sayers to have officers come by as people are pouring in and taking the aluminum siding off the house. He also mentioned the grass is very high and asked what condition the property will be in after the structure is gone. Mr. Bates said according to the contract with Z-Tech, it would be cleared and seeded. Mr. Piros said we won't okay the bill until everything is completed according to the contract with Z-Tech.

Mr. Wilson also told Chief Sayers he could put the speed radar machine in this yard.

Rita Benoit, Andrews Drive, said she would take the sewer petition to the properties on Bazetta Road, Mr. Glancy said to see him after the meeting for the petitions and the hi-lited map.

200-06 Motion by Mr. Piros, seconded by Mr. Glancy to approve the minutes of the August 21st meeting.

Vote on Motion: Mr. Bates YES, Mr. Glancy YES and Mr. Piros YES.

YES 3

NAY 0

Motion Carried.

The following correspondence was read by Fiscal Officer Martha Urchek:

1. A copy of the Grassroots was given to the trustees. This is a monthly newsletter from the Ohio Township Association. .
2. Mr. Piros sent letters to Tim Ryan, Marc Dann, Randy Law and Sandra Harwood on the article in the Tribune on August 27th regarding the Lakeshore Development Sewer Project.
3. Emailed local newspapers on meeting minutes and upcoming meetings.
4. Received a letter from Clemans & Nelson on the police union on naming a mediator if needed.
5. Received fax from Varnum, Attorney at Law, on the cable bill – HR-5232.
6. Received email from Darlene St. George on HB-23 to regulate adult entertainment establishments.
7. Received a letter from the Trumbull County Treasurer's Office on ORC-5719.42 on bidding contracts.

SEPTEMBER 05, 2006

8. Received a letter from the Trumbull County Engineer's and Trumbull County Planning Commission on the Stonegate Plat #1.
9. Received a letter from the Trumbull County Auditor on the Official Certificate of Estimated Resources for January 01, 2007.
10. Sent an ad and letters out for quotes on health care. Our contract is up 12-01-06.

201-06 Motion by Mr. Glancy, seconded by Mr. Bates to approve purchase orders.
Vote on Motion: Mr. Bates YES, Mr. Glancy YES and Mr. Piros YES.

YES 3
NAY 0
Motion Carried.

202-06 Motion by Mr. Piros, seconded by Mr. Glancy to approve payment of bills.
Vote on Motion: Mr. Bates YES, Mr. Glancy YES and Mr. Piros YES.

YES 3
NAY 0
Motion Carried.

Fire Chief McKenzie:

Chief McKenzie had nothing to report.

Road Superintendent Frank Parke:

Mr. Parke stated that Kris is working on Issue II money and is meeting with Mike Sliwinski today. The deadline is October 06th for all the paperwork to be in. It looks like we might get a project of two roads; part of Howland Wilson Road and the center of Durst Clagg Road. Mr. Bates asked what part of Durst Clagg Road and Mr. Parke said Durst Clagg from State Route 305 to Everett Hull.

Mr. Parke asked if he and one other employee from his department could attend a seminar on "Dealing with Difficult People" in Youngstown on November 13th. The cost is \$99 each. The board took this under advisement and will place it on the agenda for the next meeting.

Mr. Parke turned in his Monthly August Report to the board and stated he is keeping up with the mowing and trimming trees in the cemeteries.

SEPTEMBER 05, 2006

Police Chief Sayers:

Chief Sayers reported that the work session held on August 22nd with the trustees was very productive. He has scheduled bi-monthly meetings with supervisors with the first one being on September 01st. He will forward the minutes of this meeting to the board. At this meeting the budget and a three-year projection was discussed. It was felt that his budget couldn't handle hiring two full-time officers, but hiring one full-time officer was discussed.

Chief Sayers asked trustees to set up a meeting with the criteria being to hire a full-time police officer. The meeting is scheduled for September 12th at 7:30 PM. Mr. Piros said he wouldn't be there as he is on vacation September 09th until September 17th. Mr. Bates will attend.

The hiring of one more full-time officer will update our shift coverage from 65% to 70%. The gaps in coverage will be filled with part-time and full-time officers. The emphasis will be on shifts that need extra patrol.

Mr. Piros asked if the police negotiation meeting is still scheduled for September 06th at 9:00 AM at the police station and the answer was yes. Mr. Piros will attend.

203-06 Motion by Mr. Glancy, seconded by Mr. Piros to permanently promote Mike Hovis to Sergeant effective today at the rate of \$21.41.

Vote on Motion: Mr. Bates YES, Mr. Glancy YES and Mr. Piros YES.

YES 3

NAY 0

Motion Carried.

Mr. Bates suggested that the board look at changing all the meetings to 7:00 PM instead of the morning 9:00 AM meetings. This will be discussed at the next meeting.

Mr. Bates turned the meeting over to Vice Chairman, Mike Piros.

Mr. Bates left the meeting at 9:40 AM due to his work schedule.

Zoning Inspector Mauger:

Mr. Mauger reported the properties on 460 and 380 State Route 305 will be on the Board of Health's agenda for September 20th.

The property owner of 4278 North Park has removed the junk vehicles and has mowed the grass.

SEPTEMBER 05, 2006

The Super Wal-Mart project is moving forward. Mr. Parke suggested we videotape Millennium Drive before Super Wal-Mart starts hauling dirt in. Chief Sayers will take care of this.

Z-Tech will demolish the structure at 4054 North Park sometime next week.

Mr. Glancy asked if a house is being built on Bazetta Road north of the fairgrounds. Mr. Mauger thought it might be logging, but will investigate and give a report at the next meeting.

Safety Committee:

Chief Sayers reported the next meeting will be on Tuesday, September 06th at the police station.

Administration:

A meeting was set for a zone change hearing on property owned by Eugene Pyatt located at 484 Wilson Sharpsville Road from Residential R-1 to Commercial C-3 to be held on Monday, September 18th at 6:00 PM at the administration office.

204-06 Motion by Mr. Glancy, seconded by Mr. Piros to authorize the Fiscal Officer to transfer within the following funds:

05-A-01 Cemetery (Mowing) to 05-A-09 Cemetery (Supplies) \$2,000.00
01-A-05 Administration (Equipment) to 01-B-01 Salaries \$2,000.00
04-B-01 Road (Salaries) to 04-B-03 Road (Contracts) \$835.00

Vote on Motion: Mr. Glancy YES and Mr. Piros YES.

YES 2

NAY 0

Motion Carried.

205-06 Motion by Mr. Glancy, seconded by Mr. Piros to table the Legal Fee Contract with Mark Finamore until the next meeting, September 18th.

Vote on Motion: Mr. Glancy YES and Mr. Piros YES.

YES 2

NAY 0

Motion Carried.

The status on the Drug Free Work Place Training held in June of 2006 was that every employee has attended a meeting or has seen the video.

SEPTEMBER 05, 2006

After much discussion, the following action was taken concerning the cell phone policy:

206-06 Motion by Mr. Glancy, seconded by Mr. Piros to accept the updated cell phone policy provided by our Legal Counsel. Mr. Piros suggested Martha make a copy of the updated policy for each department head to post and to place in their Policy and Procedures Manual.

Vote on Motion: Mr. Glancy YES and Mr. Piros YES.

YES 2

NAY 0

Motion Carried.

Mr. Piros reported he had a phone conversation with Mr. Rockman on the electrical upgrade at the township park and his estimate is \$7,075. This will be discussed at the next meeting.

The Board of Trustees voted to endorse the following candidates for the November, 2006 General Election. The board felt these candidates will best support the interests of our township and perform the duties of the office to which they are seeking to be elected.

Frank Fuda for Trumbull County Commissioner
 Adrian Biviano for Trumbull County Auditor
 Tom Letson for State Representative – 64th District
 Sandra Harwood for State Representative – 65th District
 Steven LaTourette for Representative to Congress – 14th District
 Diane Grendell for 11th District Court of Appeals – Term 2/10/07 – 2/09/13
 Mary Jane Trapp for 11th District Court of Appeals – Term 2/09/07 – 2/08/13
 Marc Dann for State of Ohio Attorney General

These will be sent to the Trumbull Township Association Endorsement Committee.

207-06 Motion by Mr. Piros, seconded by Mr. Glancy to endorse the above-mentioned candidates.

Vote on Motion: Mr. Glancy YES and Mr. Piros YES.

YES 2

NAY 0

Motion Carried.

Mr. Piros reported that the Township Newsletters are in the mail to all township registered voters and if any resident would like a copy, they can pick one up at the township hall.

**BAZETTA TOWNSHIP TRUSTEES REGULAR MEETING
MONDAY, SEPTEMBER 18, 2006 AT 7:00 PM**

Present: Jeff Bates, Mike Piros, Bill Glancy, Attorney Mark Finamore, and Robyn Metheny taking the minutes.

Old Business:

Mr. Piros had nothing to report.

Mr. Glancy stated that negotiations with the police department have started.

Mr. Bates stated that talks with BWC have finished and that he will be attending an 8 hour class in Columbus.

Public Participation:

Dan Wilson, North Park Avenue, thanked the township for the demolition of the dwelling on North Park Avenue. He stated everything looks much better.

Walter Maycher, Bazetta Road, questioned the sewer petition for the dwellings on Bazetta Road and asked why they were not included in with Janet, Lynn and Andrews from the start.

Mr. Glancy stated he gave the petitions to someone at the last meeting.

Bud Bowen, State Route 5, questioned the sewer project on State Route 5. He mentioned that it came to a stop when Sidley's moved out. The trustees didn't know why.

Art Kreller, Andrews Drive, asked if the trustees had any comment on Sandra Harwood help with septic tanks. He also questioned if his development could tap into the sewer when Wal-Mart comes.

Art Kreller said there is a safety issue with the flood lights at Cole Valley.

Art Kreller asked Mr. Mauger is there were any zoning regulations on garbage cans sitting out by the street. There is a dumpster at the corner of Andrews and Janet.

Attorney Finamore stated if it is there all the time, it would be a zoning violation. If it is only there on garbage night it would not be a violation.

Mr. Mauger is to look into the matter.

SEPTEMBER 18, 2006

Mrs. Parana, Andrews Drive asked if any one has ever put a camera in to look at the sewers.

Mr. Piros stated he had researched 98 grants and forwarded the information to the county.

Linda Patterson, Woodland Trails Block Watch, brought in pictures to share with everyone

Evelyn Coe, McCleary Jacoby, asked why the Timber Creek Block Watch Meeting on October 03rd was being held at the police station and not at the administration building.

Chief Sayers stated meetings to benefit the community can be held at the police station. He also mentioned that Boy Scout meetings have been held at the station.

209-06 Motion by Mr. Piros, seconded by Mr. Glancy to transfer money within the following funds:

From 10-A-09 Fire (Supplies) to 10-A-10 Fire (Repairs) \$1,500.00
 From 10-A-14A Fire (Contracts) to 10-C-07 Fire (EMS Contracts) \$511.00
 From 10-A-09 Fire (Supplies) to 10-C-07 Fire (EMS Contracts) \$1,505.00
 From 01-A-04 Administration (Supplies) to 01-A-06 Administration (Insurance) \$1,100.00
 From 04-B-01 Road (Salaries) to 04-A-10 Road (Insurance) \$455.79
 From 01-A-26 General (Other Expenses) to 01-A-10 Legal Fees \$7,500.00

Vote on Motion: Mr. Bates YES, Mr. Glancy YES and Mr. Piros YES.

YES 3

NAY 0

Motion Carried.

210-06 Motion by Mr. Glancy, seconded by Mr. Piros to approve the minutes of the September 05th meeting.

Vote on Motion: Mr. Bates YES, Mr. Glancy YES and Mr. Piros YES.

YES 3

NAY 0

Motion Carried.

The following correspondence was read by Robyn Metheny:

1. Received a letter from LuAnn Koch, Ohio Edison Area Manager, on reporting street light outages, damages and theft at substations.

SEPTEMBER 18, 2006

2. Received a letter from Eastgate Regional Council of Governments on the Clean Ohio Conservation Fund.
3. Received Morton Salt bulk quote. This needs to be returned by September 28, 2006. Price per ton is \$38.44 compared to 2005 price per ton of \$36.94.
4. Received a letter from the Ohio Department of Natural Resources on the Nature Works Grant Program asking to take pictures of the township park facilities (restrooms renovation and sanitation sewer and the picnic pavilion) that were funded through this grant.
5. Ohio Department of Health will be distributing oral rabies vaccine in 14 northeast Ohio counties including Trumbull starting on September 05th until September 19th. Low flying planes will deliver the bait.
6. A memo was sent to the trustees about the Timber Creek Block Watch Meeting on October 03rd at 6:30 PM at the police station.
7. Received a letter from Representative Tim Ryan endorsing Ted Strickland for Ohio Governor.
8. Received an invitation for State Representative Sandra Stabile Harwood Fundraiser.
9. A memo was sent to the trustees on the receipt of the minutes from the Lakeshore Drive Sewer Meeting held on August 09th.
10. Emailed local newspapers on township minutes and meetings.
11. Release of easement of right-of-way on Tom Shortreed's property from Attorney Finamore.
12. Training Session for Public Workers to keep from coming into contact with suspected by-products and chemicals used in the manufacturing of "Meth". Three sessions offered from 9 AM until 1 PM. One session will be at our administration hall on Monday, September 25th.
13. Received OTARMA 2005 Annual Membership Report.
14. Geauga-Trumbull Solid Waste Management District 15-Year Plan.
15. Received Trumbull County Engineer letter of September 14th stating that Warren-Meadville Road will be closed until September 22nd for culvert replacement.

SEPTEMBER 18, 2006

16. Received a letter from Eastgate Regional Council of Government asking for three nominations to serve on District 6 Natural Resource Assistance Council for the Clean Ohio Conservation Fund Committee.
17. Received regular public meeting agenda for September 20th of the Trumbull County Board of Health and their meeting minutes of August 09th.
18. Received two invitations to attend seminars on Regionalization. This program is designed to take a hard look at potential working relationships with our neighbors in government.

211-06 Motion by Mr. Piros, seconded by Mr. Glancy to approve purchase orders.
Vote on Motion: Mr. Bates YES, Mr. Glancy YES and Mr. Piros YES.

YES 3
NAY 0
Motion Carried.

212-06 Motion by Mr. Glancy, seconded by Mr. Piros to approve payment of bills.
Vote on Motion: Mr. Bates YES, Mr. Glancy YES and Mr. Piros YES.

YES 3
NAY 0
Motion Carried.

Road Superintendent Parke:

Mr. Parke requested authorization to place an order to purchase 700 tons of road salt.

213-06 Motion by Mr. Bates, seconded by Mr. Glancy to place an order for 700 tons of road salt from Morton Salt at the cost of \$38.44 per ton delivered.
Vote on Motion: Mr. Bates YES, Mr. Glancy YES and Mr. Piros YES.

YES 3
NAY 0
Motion Carried.

Mr. Parke requested permission to send two road department employees to a seminar in November, 2006 for "Dealing with Difficult People" at the cost of \$99 each.

SEPTEMBER 18, 2006

214-06 Motion by Mr. Piros, seconded by Mr. Glancy to send two road department employees to a seminar in November, 2006 for "Dealing with Difficult People" at the cost of \$99 each.

Vote on Motion: Mr. Bates YES, Mr. Glancy YES and Mr. Piros YES.

YES 3

NAY 0

Motion Carried.

Bud Bowen questioned the tree on the Mackey property.

Mr. Parke stated the trunk is not in the road right-of-way, but the branches are.

215-06 Motion by Mr. Bates, seconded by Mr. Glancy to direct Attorney Finamore to send a letter to the property owner to correct this problem within a specified time limit.

Vote on Motion: Mr. Bates YES, Mr. Glancy YES and Mr. Piros YES.

YES 3

NAY 0

Motion Carried.

Mr. Parke spoke with Rick Hope of Lynn, Kittinger and Noble concerning the Stonegate Plat #1. In the future, the township should receive three copies of the preliminary maps. He also said he was working on the house numbers with the post office.

The deadline to received foundation orders to be placed in the fall has been set for October 13th.

Police Chief Sayers:

Chief Sayers discussed with the trustees the hiring of one full-time officer. His recommendation to the trustees was Shawn Rentz.

216-06 Motion by Mr. Piros, seconded by Mr. Glancy to hire Shawn Rentz as a full-time police officer at the contract rate affective September 24, 2006.

Vote on Motion: Mr. Bates YES, Mr. Glancy YES and Mr. Piros YES.

YES 3

NAY 0

Motion Carried.

Chief Sayers also introduced Mike Hovis and mentioned his promotion to sergeant. He will fill the vacancy left by Nick Papalas.

SEPTEMBER 18, 2006

Chief Sayers also requested an executive session to at the end of the meeting to discuss police contract negotiations.

Fire Chief McKenzie:

Chief McKenzie had nothing to report.

Zoning Inspector Mauger:

Mr. Mauger has nothing to report at this time.

Safety Committee:

Chief Sayers discussed the September 06th meeting.

Park Board:

Evelyn Coe of the park board submitted to the trustees a quote from Jeff Mauger for landscaping around the gazebo at the township park. (See attachment)

Also attached is the estimate from the Trumbull County Engineer's Office for the road grading for the park driveway.

After much discussion the trustees made the following motion:

217-06 Motion by Mr. Piros, seconded by Mr. Glancy to approve Phase 1 at the estimate of \$7,500 to \$8,000 and Phase 2 at the estimate of \$1,700 to \$1,900 along with the Trumbull County Engineer's estimate for the road grading of the park driveway of \$2,781.50. Using all the higher figures from Jeff Mauger and rounding off the engineer's estimate to \$3,000 the approval was for \$12,900. Jeff Mauger is approved pending receiving a copy of his BWC and Insurance Liability and also he will need to sign off on our Drug Free Work Place Policy. Vote on Motion: Mr. Bates YES, Mr. Glancy YES and Mr. Piros YES.

YES 3

NAY 0

Motion Carried.

Evelyn Coe questioned if Jeff Mauger could have any money in advance to make the purchases. The trustees replied no, but if he requested, he could be paid after each phase was completed. The park board is to notify the fiscal officer that they are satisfied with the work before any payment is made.

SEPTEMBER 18, 2006

Trustee Piros stated that there would be no electrical work done at the township park this year.

Administrative Office:

After much discussion on the Legal Fee contract with Attorney Finamore, the trustees made the following motion:

218-06 Motion by Mr. Piros, seconded by Mr. Bates to approve the contract with Attorney Finamore starting September 01, 2006 for a cost of \$800 per month for 8 hours of legal service. Anything over the 8 hours per month will be billed at \$100 per hour. (See attachment)
Vote on Motion: Mr. Bates YES, Mr. Glancy YES and Mr. Piros YES.

YES 3

NAY 0

Motion Carried.

A zone change hearing was held earlier this evening at 6:00 pm for a request to change the zoning of property at 484 Wilson Sharpville Road, owned by Eugene and Luetta Pyatt, from a classification of Residential "R" to Commercial "C-3".

219-06 Motion by Mr. Piros, seconded by Mr. Glancy to approve the zone change request for property at 484 Wilson Sharpville Road, owned by Eugene and Luetta Pyatt, from Residential "R" to Commercial "C-3". This change will go into effect in 30 days.
Vote on Motion: Mr. Bates YES, Mr. Glancy YES and Mr. Piros YES.

YES 3

NAY 0

Motion Carried.

Trustees discussed our TPA Professional Risk Management Workers' Compensation annual service fee of \$3,800 for August 01, 2006 through July 31, 2007. The fee for August 01, 2005 through July 31, 2006 was \$2,400.

220-06 Motion by Mr. Glancy, seconded by Mr. Piros to approve our Third Party Administrator (TPA) Professional Risk Management Workers' Compensation annual service fee of \$3,800.00 for August 01, 2006 through July 31, 2007.

Vote on Motion: Mr. Bates YES, Mr. Glancy YES and Mr. Piros YES.

YES 3

NAY 0

Motion Carried.

SEPTEMBER 18, 2006

There was a discussion on the East Side Sewer Project regarding a letter to Eaton Development from the Trumbull County Sanitary Engineer's office. Mr. Piros stated that there was a deadline given.

Fiscal Officer Urchek notified the trustees that Michael Collins from Genesis Electric was to attend the meeting tonight to discuss the Timber Creek Heights Street Lights. He did not show. Mr. Piros stated that he has called Mr. Collins six times to discuss his bid. Mr. Piros has not received a call back from him.

Mr. Piros also stated that a quote was received from Bob Luscher.

A total of three quotes were received: Valley Electric \$16,400/Genesis \$7,250 and Bob Luscher at \$11,080.

Attorney Finamore stated that a letter should go out to Mr. Collins by certified mail. Mr. Piros will write the letter.

The trustees discussed the need for another 5 drawer steel flat file cabinet for maps to be stored in.

221-06 Motion by Mr. Glancy, seconded by Mr. Piros to authorize the purchase of a 5 drawer steel flat file cabinet from Grainger at the approximate cost of \$517.05. This cabinet will be used in the zoning office for the storage of various maps.

Vote on Motion: Mr. Bates YES, Mr. Glancy YES and Mr. Piros YES.

YES 3

NAY 0

Motion Carried.

Trustee Bates discussed changing all Regular Trustee Meetings to the first and third Mondays of each month at 7:00 PM and to dispense with the 9:00 AM meeting.

Mr. Glancy did not have a problem with the change.

Mr. Piros stated that since there were only three more 9:00 AM meetings that the change should wait until the organizational meeting at the first of the year.

222-06 Motion by Mr. Bates, seconded by Mr. Glancy to change all Regular Trustee Meetings to the first and third Mondays of each month at 7:00 PM and to dispense with the 9:00 AM meeting starting in October, 2006.

Vote on Motion: Mr. Bates YES, Mr. Glancy YES and Mr. Piros NO.

SEPTEMBER 18, 2006

YES 2

NAY 1

Motion Carried.

Chief Sayers reminded everyone that they need to be in compliance with the required NIMS Training for the 700 and 800 course by September 30, 2006.

All copies of those who have completed the NIMS Training are to be on file with Fire Chief McKenzie.

Trustees discussed the Release of Nuisance Abatement Lien Tax Assessment for 941 and 947 Johnson Plank Road.

223-06 Motion by Mr. Piros, seconded by Mr. Glancy to go into executive session at 8:58 PM to discuss police negotiations.

Vote on Motion: Mr. Bates YES, Mr. Glancy YES and Mr. Piros YES.

YES 3

NAY 0

Motion Carried.

Trustees returned to regular session with no action taken.

224-06 Motion by Mr. Piros, seconded Mr. Glancy to adjourn the meeting.

Vote on Motion: Mr. Glancy YES and Mr. Piros YES.

YES 2

NAY 0

Motion Carried.

By Motion Adjourned.

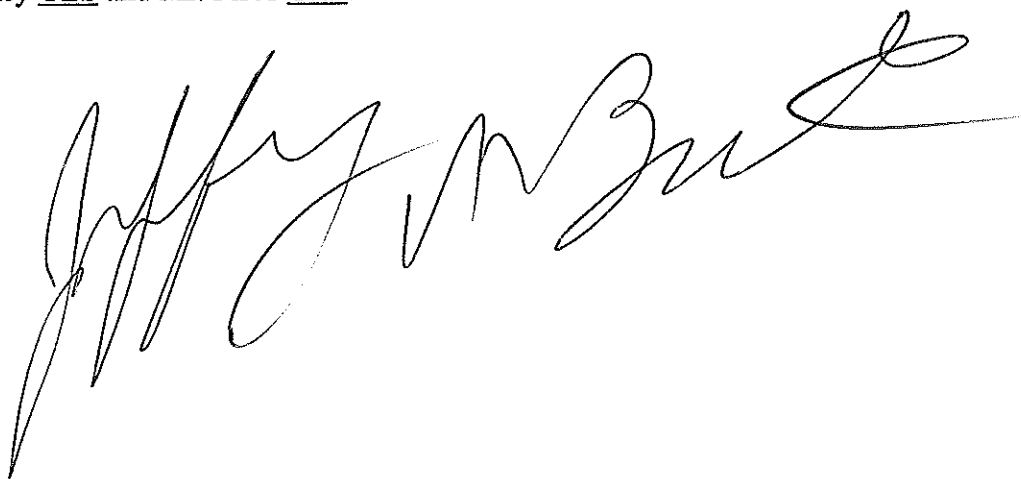

9/17/06
This estimate is for landscaping around the gazebo at Bazetta Park.

Phase 1

3 White Dogwood
5 Little Princess Spirea
7 Rhododendron
5 Juniper
5 Weigela
25 Daylilies
31 Boxwood

This includes planting in front and rear of the gazebo and includes all required topsoil, mulch and labor.

\$7500 to \$8000, this price depends on the size of the plants being installed.

Phase 2

Installation of 5 Flowering Crabapple Trees with topsoil and mulch around trees.

\$1700 to \$1900, again this depends on the size of the trees.

Phase 3

The third phase would include an installation of a brick walkway approximately 500 square feet. The price of this solely depends on the type of brick pavers being used therefore an accurate estimate can not be done until the brick style is chosen. When ready for this phase, an accurate estimate would be given.

Thank you,
Jeff Mauger
330-638-6338



TRUMBULL COUNTY ENGINEER

650 NORTH RIVER ROAD, N.W.
WARREN, OHIO 44483
PHONE: (330) 675-2640 FAX: (330) 675-2642

John D. Latell Sr., P.E./P.S.
Engineer

Randy L. Smith, P.E./P.S.
Deputy Engineer

September 1, 2006

Bazetta Township Road Department
3372 State Route 5
Cortland, Ohio 44410
Attn: Frank Parke, Road Supt.

Re: Road Grading to Township Park Driveway

Frank:

The following is the Estimate that you requested for the Grading of the Township Park driveway in Bazetta Township. Please be aware that this is just an estimate and labor times could change once out in the field.

The material estimates are using figures from our current Contract prices. However, we would ask the Township to purchase materials directly from the supplier which could alter the total cost.

GRADING and ROLLING the TOWNSHIP PARK DRIVEWAY MATERIAL

MATERIAL	QUANTITY	COST PER TON/GALLON	TOTAL
#8 Blast Furnace Slag	50 tons	\$13.25	\$662.50
MC-70 Emulsion	500 gallons	\$1.6820	\$841.00
			\$1,503.50

LABOR (@ time and 1/2)

CLASSIFICATION	PER HOUR	TOTAL
Truck Driver	\$34.22 (4 hours)	\$136.88
Equipment Operator	\$35.66 (32 hours)	\$1,141.12
		\$1,278.00

All other requirements of the County Engineer concerning liability and insurance would apply.

If you have any questions or would like to schedule this work, please call me at the office (330) 675-2640.

Sincerely,

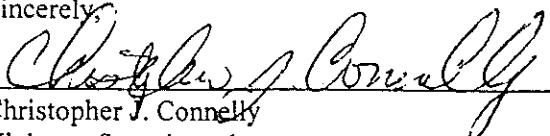
Christopher J. Connelly
Highway Superintendent

CJC/hlh
xc: file

330-793-9381

SAFCO
an LDI Company

STEEL FLAT FILES

MODEL 4994, 4996, 4998
NUMBERS 4976, 4986

A No 4KH60

IMPORTANT ASSEMBLY INSTRUCTIONS

PARTS:

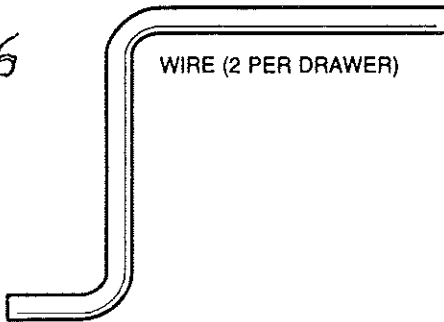
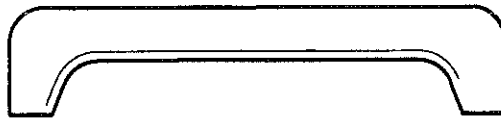

SCREWS
(4 PER
DRAWER)



LABEL HOLDERS (1 PER DRAWER)

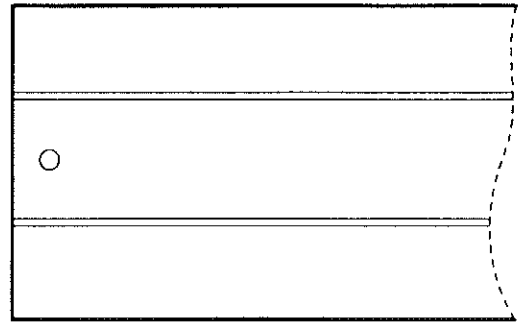
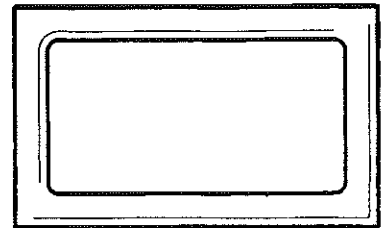

PAPER HOLDER (1 PER DRAWER)

1 Lay cabinet on bottom side and remove all drawers (lift drawer slightly after it reaches its stop).

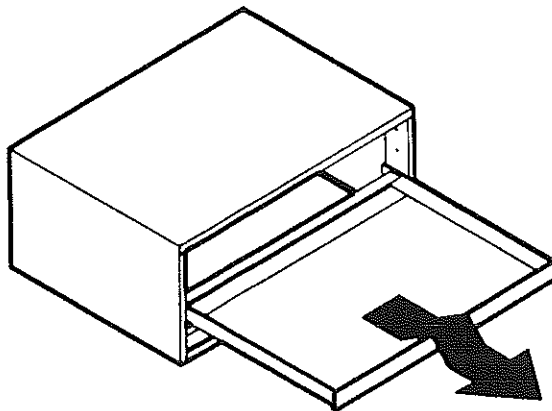

2 Lower cabinet onto base and replace drawer. NOTE: Base sold separately.

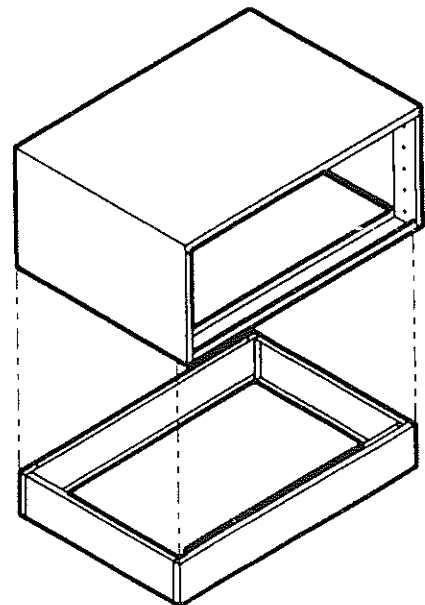

**BAZETTA TOWNSHIP TRUSTEES REGULAR MEETING
MONDAY, OCTOBER 02, 2006 AT 7:00 PM**

Present: Jeff Bates, Mike Piros, Bill Glancy, and Robyn Metheny taking the minutes.

Old Business:

Mr. Piros mentioned that a letter went out to residents on the north side of Northview and several homes on Williams asking for an easement. Any questions on this should be directed to Mr. Johnson at the Sanitary Engineer's Office.

Mr. Piros also noted that in talking with Don Waldron he was informed that the deadline of September 30th for the NIMS 800 series was for first responders.

Mr. Piros, Mr. Parke and Mr. Governor met at the township park today concerning damage that was done in the men's restroom.

It was agreed by all three trustees to close the restrooms for the year.

Mr. Glancy stated that negotiations went well.

Mr. Bates stated that that he has completed the last request with Workers' Comp for this year. He suggested that department heads talk with their employees each morning concerning physical conditions. They should listen as to whether they were hurt in any way while off duty.

Public Participation:

Mrs. Perhach questioned whether there was any information on the pilot water project. Trustees didn't know of a pilot water project.

Art Kreller, Andrews Drive, requested someone from the township to check into the manhole covers in the woods by the railroad tracks. He felt a child could get hurt.

Mr. Parke was directed to go and check the situation out.

225-06 Motion by Mr. Bates, seconded by Mr. Glancy to authorize the Fiscal Officer to transfer money within the following funds:

10-A-14 Fire (Insurance) to 10-A-02 Fire (Employers Retirement Cont.) \$7,000.00
 01-A-15 General (Workers' Comp) to 01-A-12 General (Employers Retirement Cont.) \$2,722.22
 01-A-29 General (Contracts) to 01-A-12 General (Employers Retirement Cont.) \$10,000.00
 01-A-27 General (Transfers) to 01-A-12 General (Employers Retirement Cont.) \$12,785.79
 09-A-14 Police (Other Expenses) to 09-A-02 Police (Employers Retirement Cont.) \$18,258.21

OCTOBER 02, 2006

01-A-27 General (Transfers) to 01-F-02 Park (Improvement of Site) \$1,800.00
01-F-09 Park (Special Events) to 01-F-02 Park (Improvement of Site) \$1,000.00
01-A-27 General (Transfers) to 01-A-10 Legal Counsel \$5,000.00
01-A-21 General (Election Expenses) to 01-A-06 General (Insurance) \$2,382.94

Vote on Motion: Mr. Bates YES, Mr. Glancy YES and Mr. Piros YES.

YES 3

NAY 0

Motion Carried.

226-06 Motion by Mr. Piros, seconded by Mr. Glancy to accept the amount of rates as determined by the Budget Commission and authorizing the necessary tax levies and certifying them to the Trumbull County Auditor.

Vote on Motion: Mr. Bates YES, Mr. Glancy YES and Mr. Piros YES.

YES 3

NAY 0

Motion Carried.

227-06 Motion by Mr. Piros, seconded by Mr. Glancy to approve the minutes of the September 18th meeting.

Vote on Motion: Mr. Bates YES, Mr. Glancy YES and Mr. Piros YES.

YES 3

NAY 0

Motion Carried.

The following correspondence was read by Robyn Metheny:

1. A letter from the township was sent to Genesis Electric regarding their bid for the Timber Creek Heights street light project.
2. A public meeting on Sewage Treatment System Rules will be held in Canfield on Wednesday, November 08th from 6 to 8 PM.
3. Received the Fall Brochure from Soil and Water Conservation District.
4. Received an invitation to attend the Midwest Premier Construction Claims Seminar on November 09th in Columbus.

OCTOBER 02, 2006

5. Emailed local newspapers on 9-18-06 meeting minutes,
6. Received brochure from CorVel, our MCO, for September.
7. Received meeting notice on Wal-Mart Supercenter Bazetta Road and Millennium Boulevard Intersection Alternative will be on Tuesday, September 26th at 2 PM at the Planning Commission.
8. Received letter from the Trumbull County Planning Commission on the Maintenance Bond for Stonegate Plat #1.
9. Received an email from Darlene St. George on various state issues.

228-06 Motion by Mr. Glancy, seconded by Mr. Piros to approve purchase orders.

Vote on Motion: Mr. Bates YES, Mr. Glancy YES and Mr. Piros YES.

YES 3

NAY 0

Motion Carried.

229-06 Motion by Mr. Piros, seconded by Mr. Bates to approve payment of bills.

Vote on Motion: Mr. Bates YES, Mr. Glancy YES and Mr. Piros YES.

YES 3

NAY 0

Motion Carried.

Fire Chief McKenzie:

Chief McKenzie stated that he received the Residential Fire Safety Achievement Award in the mail today.

He also stated that in 2007 it looks like we will receive the Fire Fighters Assistant Grant which would consist of a set of cribbing, set of air bags, 2 saws, and a complete set of rescue hydraulic tools.

Chief McKenzie also discussed with the trustees a letter that needs to be sent to L & D Medical to cancel their contract with the township as of January, 2007.

OCTOBER 02, 2006

230-06 Motion by Mr. Piros, seconded by Mr. Glancy to send a letter to L & D Medical to cancel their contract with the township as of January, 2007. Chief McKenzie is to draft up a letter and give to Mr. Piros to type and send out.

Vote on Motion: Mr. Bates YES, Mr. Glancy YES and Mr. Piros YES.

YES 3

NAY 0

Motion Carried.

Ohio Billing will be the new company we will go with.

Chief McKenzie submitted the following quotes he received to replace windows and exterior doors at Station #11 and Station #13:

Hayco Remodelers Inc.

Station #13 \$6,200.00

Station #11 \$10,050.00

Total: \$16,250.00 (Windows and Doors)

Raub Construction

Station #13 \$12,500.00

Station #11 \$21,000.00

Total: \$34,000.00 (Windows & Doors)

Little Wing Construction

Station #13

Station #11

Total: \$11,000.00 (Just Windows)

231-06 Motion by Mr. Glancy, seconded by Mr. Piros to accept the quote of \$16,250.00 from Hayco Remodelers Inc., for the replacement of windows and doors at Station #11 and #13.

Vote on Motion: Mr. Bates YES, Mr. Glancy YES and Mr. Piros YES.

YES 3

NAY 0

Motion Carried.

Trustees requested the bids be signed and dated by the company and that the work be done this year.

SEPTEMBER 02, 2006

Road Superintendent Parke:

Mr. Parke notified the trustees that Warren Fire would be out on Wednesday, October 04th to service all township fire extinguishers.

Mr. Parke also questioned the right-of-way on the deed for the administration property.

Mr. Bates is to call Attorney Finamore on the matter of the right-of-way.

Mr. Parke stated that the trustees needed to make a motion to have the state install a "Stop" sign on Stonegate and to also set the speed limit on Stonegate at 25 MPH.

232-06 Motion by Mr. Piro, seconded by Mr. Glancy to pass a resolution to set the speed limit on Stonegate at 25 MPH and to also authorize the state to install a "Stop" sign on Stonegate.
Vote on Motion: Mr. Bates YES, Mr. Glancy YES and Mr. Piro YES.

YES 3

NAY 0

Motion Carried.

Mr. Parke submitted the following quotes he received on equipment rental (Mini Excavator) for the Prince Drive drainage project:

Cat Rental	\$700.00
Leppo	\$896.00
Kinsman Rental	\$690.00

233-06 Motion by Mr. Glancy, seconded by Mr. Piro to accept the quote of \$690.00 from Kinsman Rental for the equipment rental (Mini Excavator) for the Prince Drive project. (If Kinsman Rental is not available, Mr. Parke is permitted to spend up to \$700.00)
Vote on Motion: Mr. Bates YES, Mr. Glancy YES and Mr. Piro YES.

YES 3

NAY 0

Motion Carried.

There was a discussion on the grading of the drive at the park. Martha is to send a letter out that the amount was approved.

John Klamut questioned if there was a safety issue on the Stonegate entrance?

BAZETTA FIRE DEPARTMENT

STATION 11

773 EVERETT-HULL RD
 CORTLAND, OHIO 44410
 (330) 637-4136 FAX (330) 638-4193

STATION 13



Chief
 Clyde McKenzie

Captain
 Dennis Lewis

Captain
 Tom S. Rink

Lieutenant
 Brian Taylor

To: Bazetta Township Trustees
 Date: 9/27/06
 Re: Replacement windows and Doors

Dear Sir,

We have had three companies come in and give us quotes on windows and doors at Station 11 & 13 this is the break down. We would like to have this completed before winter to save fuel and elec. This year.

Hayco Remodelers Inc.
 Station#13 \$ 6,200.00
 Station #11 \$ 10,050.00 Total Cost \$ 16,250.00 Windows & Doors

Raub Construction Corp.
 Station#13 \$ 12,500.00
 Station#11 \$ 21,000.00 Total Cost \$ 34,000.00 Windows & Doors

Little Wing Construction
 Station#13
 Station#11 Total Cost \$ 11,000.00 Just Windows

**BAZETTA TOWNSHIP TRUSTEES REGULAR MEETING
MONDAY, OCTOBER 16, 2006 AT 7:00 PM**

Present: Jeff Bates, Mike Piros, Bill Glancy, and Mark Finamore, Legal Counsel.

Old Business:

Mr. Piros reported on the septic tank rules and regulations that will take effect on January 01, 2007. There will be a meeting on Wednesday, November 08th from 6-8 PM in Canfield, Ohio.

He received a letter from the Trumbull County Sanitary Engineer, Gary Newbrough, on the East Central Bazetta Sewer Improvement Projects which will include some properties on State Route 46.

The Board of Appeals recently met on Stonegate and only approved 20 lots. A new Notice of Appeal request will need to be re-applied for the additional 11 lots.

Mr. Glancy who also attended the Board of Appeals meeting felt the Chairman, Mr. Koper, did not treat Mr. Hope, the engineer, fairly. Mr. Glancy thought he was very rude to Mr. Hope.

Mr. Glancy further stated that due to tonight's meeting, he was unable to attend a meeting that State Representative Tim Grendell of Geauga County was hosting on the new septic tank rules and regulations. Mr. Glancy will get in touch with Mr. Grendell's office in hopes of setting up a meeting here.

Mr. Bates said he received a complaint regarding a basketball hoop that is located in the township's right-of-way on Timber Way Drive in Timber Creek. A letter was sent to the resident and as of this date the basketball hoop is still there. School buses have hit the basketball hoop as well as our snowplow last year. Mr. Glancy asked that this has been a problem that long that it involved our snowplows last year.

Mr. Bates said if it is not removed, we are permitting children to play in the streets. He suggested it be moved back 18'. Mr. Parke said they are willing to move it back. He will contact them again as the 14 days from the date of the letter is October 19th.

Tom Miller, Bazetta Road and also a township police officer, said a bus could hit it.

Mr. Finamore said to have it moved, as it is a law.

OCTOBER 16, 2006

Public Participation:

Cheryl Tennant, Perkins-Jones Road, asked the board if anyone has paid their personal use of the township issued cell phone. The reply was no. At this time, Mark Finamore explained the cell phone policy and the revised cell phone policy. He said there was no extra cost to the township because the personal minutes used were within the plan. He said because of the amount of work involved in going over past cell phone statements to determine a reimbursement amount, he suggested to the board that they take no action unless a finding recovery was issued by the auditor when the township has its annual audit.

Mrs. Tennant further stated they you are the trustees and you used then illegally, so you should be checking everyone else's to make sure they aren't making personal calls.

Mr. Finamore further stated that there is a distinction between the trustees' phones and employees' phones. Trustees can pass a resolution allowing employees to use them for personal calls and get reimbursed as trustees have done with their revised policy.

Mr. Bates turned in his township issued cell phone and purchased a personal cell phone because he does not have a home phone. He is reimbursing the township \$20 a month for every month he used the township phone for personal use.

Mr. Glancy read off his phone bill that says zero for long distance and Mrs. Tennant said the bill may say zero but you still used it for personal use. After some discussion between Mr. Glancy and Mrs. Tennant, Mrs. Tennant said she is not done with that issue with Mr. Glancy and referred to the Bureau of Criminal Investigation (BCI).

Bud Bowen, State Route 5, said if you make a personal call on the township issued cell phone, pay for it.

Mr. Piros said he will get with the department heads and discuss pro-rating the bills. Mrs. Tennant said the trustees should enforce the policy for themselves as well as the employees.

Mr. Bowen said cell phones should be banned.

Mrs. Tennant asked the board about the \$10,000 landscaping bid for the township park and asked how many bids did you receive? Mr. Bates said only one bid was received from the park board.

Jack Governor, McCleary Jacoby Road, said several bids were sent out, but Jeff Mauger was the only one that responded.

OCTOBER 16, 2006

Mr. Bowen said he works for Adgates and does bidding for them. Mr. Bates said he is doing the landscaping on his own, not with Adgates.

Mrs. Tennant asked the board about the opt-out for insurance benefits to employees, Mr. Finamore explained if the employee elected to go with their spouse's health care and there was a cost for the spouse's health care, the township would reimburse the employee once a year 20% of what it would have cost the township to have that employee covered under the health care package. She asked if anyone took advantage of that and only one this year and possible two employees for next year.

Mr. Finamore suggested Resolution #232-04 passed on September 20, 2004 should be revised to include the following:

"Move to amend Resolution #232-04 which established a group health insurance opt-out plan pursuant to Section 505-063 (ORC) to set the cash payment in lieu of group health care insurance benefits to a monthly cash payment equal to 20% of the average monthly health insurance premium of covered officials and employees."

236-06 Motion by Mr. Piros, seconded by Mr. Glancy to authorize the Fiscal Officer to transfer money within the following funds:

10-A-11 Fire (Training) to 10-A-02 Fire (Employers Retirement Cont.) \$2,000.00
 10-A-08 Fire (Tools) to 10-A-05 Fire (Employers Retirement Cont.) \$2,000.00
 10-A-01B Fire (Mechanic Salary) to 10-A-02 Fire (Employers Retirement Cont.) \$2,000.00
 13-A-03 Zoning (Supplies) to 13-A-02 Zoning (Expenses) \$300.00
 04-B-01 Road (Salaries) to 04-A-10 Road (Life Insurance) \$200.00
 01-A-27 General (Transfers) to 01-A-10 Legal Counsel \$8,000.00
 04-B-01 Road (Salaries) to 04-A-04 Road (Tools & Equipment) \$300.00
 04-B-01 Road (Salaries) to 04-A-10 Road (Insurance - Rx) \$200.00
 13-A-03 Zoning (Supplies) to 13-A-02 Zoning (Expenses) \$200.00
 10-A-14 Fire (Insurance) to 10-C-07 EMS (Contracts) \$5,000.00
 10-A-08 Fire (Tools & Equipment) to 10-C-08 EMS (Other Expenses) \$1,000.00
 10-A-08 Fire (Tools & Equipment) to 10-A-10 Fire (Repairs) \$1,000.00
 10-A-14 Fire (Insurance) to 10-A-10 Fire (Repairs) \$2,000.00

Vote on Motion: Mr. Bates YES, Mr. Glancy YES and Mr. Piros YES.

YES 3

NAY 0

Motion Carried.

OCTOBER 16, 2006

237-06 Motion by Mr. Piros, seconded by Mr. Glancy to amend Resolution #232-04 which established a group health insurance opt-out plan pursuant to Section 505-063 (ORC) to set the cash payment in lieu of group health care insurance benefits to a monthly cash payment equal to 20% of the average monthly health insurance premium of covered officials and employees.
Vote on Motion: Mr. Bates YES, Mr. Glancy YES and Mr. Piros YES.

YES 3

NAY 0

Motion Carried.

Ron Snell, 3719 Bazetta Road, had concerns about the property behind and beside his house. The grass needs cut, junk cars need removed and garbage needs cleaned up. Mr. Snell said they had an on-going garage sale of about 6 weeks and the stuff that didn't sell is still in the yard. Mr. Mauger said that the junk cars have been removed and Mr. Glancy said they were just moved into the woods. Mr. Snell would like to know if the township could get the grass cut.

238-06 Motion by Mr. Piros, seconded by Mr. Glancy to have Mr. Finamore send the property owner another letter with the stipulation to cut the grass within 7 days of the letter or the township will cut it and will forward the bill to the property owner to reimburse the township.
Vote on Motion: Mr. Bates YES, Mr. Glancy YES and Mr. Piros YES.

YES 3

NAY 0

Motion Carried.

Mr. Finamore suggested to Mr. Snell that he take pictures and to make a list and forward them on to the township of his concerns.

Mr. Glancy said there are three trailers with one septic tank. Mr. Finamore said septic tanks are a county problem, not the township.

239-06 Motion by Mr. Piros, seconded by Mr. Glancy to approve the minutes of the October 02nd meeting.

Vote on Motion: Mr. Bates YES, Mr. Glancy YES and Mr. Piros YES.

YES 3

NAY 0

Motion Carried.

OCTOBER 16, 2006

The following correspondence was read by Martha Urchek:

1. Lead Awareness Health Fair 10-13-06 at Packard Music Hall.
2. Invitation to the OTA Winter Conference NOTA Annual Legislative Breakfast on Thursday, February 01, 2007.
3. Mahoning Valley Safety Council sponsoring "Smoking Cessation Programs" on Wednesday, October 11th.
4. Citizens for Community Values is sponsoring "Zoning, Licensing and Regulation of Sexually Oriented Businesses" on Friday, November 03rd in Columbus.
5. Email from Darlene St. George on Property Rights Legislation.
6. Letter from Health Index stating due to the death of the owner, Dave Serroka, his son Paul will be taking over the business providing the same quality service for our drug free work place testing.
7. Invitation for Block Watch meeting and Halloween Bash for Ivy Hills on October 22nd.
8. Invitation from Regional Chamber on Regionalization Summit on Wednesday, October 18th.
9. Trumbull County Board of Health Meeting Agenda for Wednesday, October 18th and regular meeting minutes of September 20th meeting.
10. Request from OTARMA for candidates for Board of Directors.
11. Emailed local newspapers on meeting minutes and zoning minutes.
12. Letter from Legal Counsel, Mark Finamore, on Health Insurance Benefits Options.
13. Invitation from Professional Risk Management (our TPA) on a seminar on BWC Safety Information and Healthcare Update on November 07th.
14. Information from EPA regarding General Motors Corporation.
15. Letter from Darlene St. George on the Fire/EMS Services Evaluation Project and cost. (15% for Bazetta of \$29,800)

OCTOBER 16, 2006

Mr. Piros mentioned at the last meeting the health care deadline had been extended to October 16th and he would like to form a committee consisting of 2 representatives from the fire and police departments as well as the trustees and fiscal officer. He asked the department heads to submit two names to the fiscal officer before Monday, October 23rd. After the names are submitted, a meeting will be held to open the health care bids.

Janet Perhach asked why the road department was left out and Mr. Piros said because they are going with the Teamsters health care insurance plan.

246-06 Motion by Mr. Piros, seconded by Mr. Glancy to reject all bids for the Timber Creek Heights street lighting project due to the wide spread of bids and to re-bid this after the first of the year.

Vote on Motion: Mr. Bates YES, Mr. Glancy YES and Mr. Piros YES.

YES 3

NAY 0

Motion Carried.

Mr. Piros said he sent a letter to the lowest bidder, Genesis who had the lowest bid of \$7,250 and a 14 day time frame to respond and they never did. These bids were for the installation only. Mr. O'Brien from Ohio Edison suggested that we bid the entire job out. We were going to purchase the lights from Ohio Edison.

After discussing the state pricing of \$60 per service for Shred-it, it was decided by the board that no action would be taken as each department has their own shredder.

247-06 Motion by Mr. Bates, seconded by Mr. Glancy to go into executive session at 8:55 PM with Chief Sayers for possible employee discipline.

Vote on Motion: Mr. Bates YES, Mr. Glancy YES and Mr. Piros YES.

YES 3

NAY 0

Motion Carried.

248-06 Motion by Mr. Piros, seconded by Mr. Bates to return to regular session at 9:13 PM with no action taken.

Vote on Motion: Mr. Bates YES, Mr. Glancy YES and Mr. Piros YES.

YES 3

NAY 0

Motion Carried.

OCTOBER 16, 2006

249-06 Motion by Mr. Bates, seconded Mr. Glancy to adjourn the meeting at 9:14 PM.

Vote on Motion: Mr. Bates YES, Mr. Glancy YES and Mr. Piros YES.

YES 3

NAY 0

Motion Carried.

By Motion Adjourned.

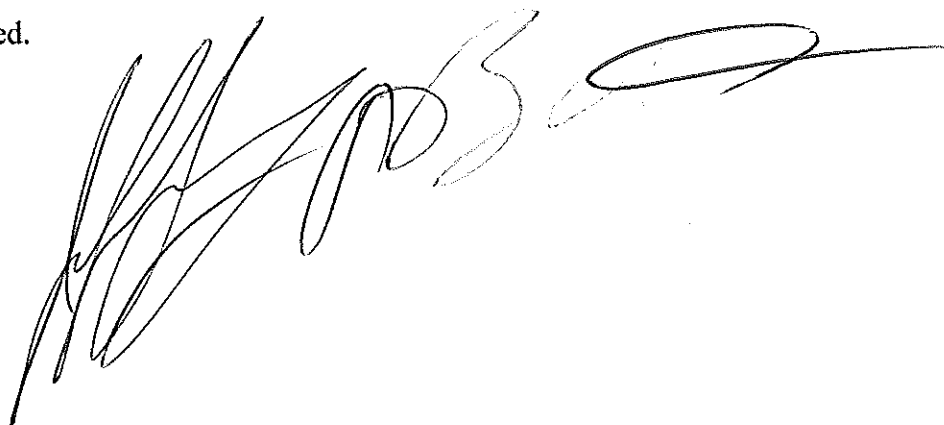
A large, stylized handwritten signature in black ink, appearing to be a cursive representation of the name 'Bates'.

1 2 3 4 5 6 7 8 9 10 11 12 13 14 15 16 17 18 19 20 21 22 23 24 25 26 27 28 29 30 31 32 33 34 35 36 37 38 39 40 41 42 43 44 45 46 47 48 49 50 51 52 53 54 55 56 57 58 59 60 61 62 63 64 65 66 67 68 69 70 71 72 73 74 75 76 77 78 79 80 81 82 83 84 85 86 87 88 89 90 91 92 93 94 95 96 97 98 99 100

1 2 3 4 5 6 7 8 9 10 11 12 13 14 15 16 17 18 19 20 21 22 23 24 25 26 27 28 29 30 31 32 33 34 35 36 37 38 39 40 41 42 43 44 45 46 47 48 49 50 51 52 53 54 55 56 57 58 59 60 61 62 63 64 65 66 67 68 69 70 71 72 73 74 75 76 77 78 79 80 81 82 83 84 85 86 87 88 89 90 91 92 93 94 95 96 97 98 99 100

1

1

1

**BAZETTA TOWNSHIP TRUSTEES REGULAR MEETING
MONDAY, NOVEMBER 06, 2006 AT 7:00 PM**

Present: Jeff Bates, Mike Piros and Bill Glancy.

Old Business:

Mr. Piros mentioned he will attend a meeting in Canfield on Wednesday, November 08th on the new sewage system rules and regulations which will go into effect on January 01, 2007.

Mr. Glancy said he attended a zoning meeting on November 01st along with Mr. Piros and Mr. Mauger on the Stonegate Development.

Mr. Bates said the basketball hoop in Timber Creek was moved two weeks ago and anticipates no further problems.

Public Participation:

Carol Glancy, Bazetta Road, asked Mr. Mauger if the same zoning rules apply to the west side as well as the east side of the township. Mr. Mauger said yes. Mrs. Glancy then asked why nothing is getting done about the Medzie property. Mrs. Glancy said there is a big pile of garbage and if the wind blows, it could be all over her yard. Mr. Mauger said he sent a certified letter which was signed by Chris Medzie on November 04th to have the garbage cleaned up by Monday, November 13th. Mrs. Glancy asked who Mr. Medzie was and Mr. Mauger said he was Carl Medzie. Mrs. Glancy said Carl has dementia and Mr. Mauger should talk to Chris Medzie. Mr. Mauger said Mr. Finamore sent a letter to Mr. Medzie on the weeds last Friday.

Mr. Glancy said when Chief Sayers and Mr. Mauger were there, he was told that the property owner, Carl Medzie, lived in Florida. Chief Sayers said he didn't mention that to Mr. Glancy and possibly Mr. Mauger did.

Mr. Piros went by the property and said the weeds and garbage are bad. Mr. Glancy said it has been that way for two months.

Mrs. Glancy asked if all the garbage would be removed by Monday and Mr. Mauger replied if not, he will send a letter to the Board of Health as they won't do anything until they receive a letter from the township.

Mr. Piros told Mr. Mauger to keep in touch with the Board of Health.

Mr. Glancy asked Mr. Mauger about the junk cars and Mr. Mauger said there is a license on very car and Mr. Glancy asked if they run and Mr. Mauger replied he didn't know.

NOVEMBER 06, 2006

Chief Sayers stated abandoned cars have missing parts and are inoperable. Mr. Glancy asked Chief Sayers if cars without tires and motors can run and the reply was no.

Cheryl Tennant, Perkins-Jones Road, said the zoning rules pertain to certain plates. Maybe the zoning rules need to be updated.

Mr. Piros told Mr. Mauger to consider that change to the zoning rules.

Mrs. Tennant asked the Board about the executive session they went into at the last meeting about the criminal investigation of a police officer and no action was taken.

Mr. Bates said no action taken.

Mrs. Tennant brought up the recent Howland Police Officer who was terminated because of his actions.

Mr. Piros said our legal counsel was present at the executive session.

Mrs. Tennant said they didn't "no bill it" and it went to the grand jury and you do nothing. What base did you make your decision?

Bud Bowen, State Route 5, said it was printed in the newspaper "full-time service date". Mr. Bates said no final decision was taken. Mrs. Tennant said no action taken. It should have been tabled.

Mr. Bates said end result- no. Mr. Piros said this is not finished yet. The board will confer with legal counsel and have an answer at the next meeting.

250-06 Motion by Mr. Glancy, seconded by Mr. Piros to authorize the Fiscal Officer to transfer within a fund the following:

Fire:

10-A-90 (FICA/Medicare) to 10-A-02 (Retirement Contributions)	\$8,550.00
---	------------

Road:

05-A-09 (Supplies) to 05-A-07 (Repairs)	\$ 500.00
---	-----------

Vote on Motion: Mr. Bates YES, Mr. Glancy YES and Mr. Piros YES.

NOVEMBER 06, 2006

YES 3NAY 0

Motion Carried.

251-06 Motion by Mr. Piros, seconded by Mr. Glancy to authorize the Fiscal Officer to transfer within a fund the following:

General Fund:

01-A-27 (Transfers) to 01-A-16 (General Health District)	\$3,600.00
01-A-28 (Adm. & Sec. Salary) to 01-A-29 (Contracts)	1,500.00
01-A-27 (Transfers) to 01-B-01 (Salaries)	500.00

Road & Bridge Fund 4:

04-B-01 (Salaries) to 04-A-05 (Supplies)	\$ 500.00
04-B-01 (Salaries) to 04-A-15 (Auditor & Treasurers Fees)	750.00
04-B-01 (Salaries) to 04-A-13 (Other Expenses)	50.00

Cemetery Fund 5:

05-A-13 (Unemployment) to 05-A-07 (Repairs/Maint.)	\$ 600.00
--	-----------

Police Fund 9:

09-A-01 (Salaries) to 09-A-04 (Auditor & Treasurer Fees)	\$3,500.00
--	------------

Police Dist. Equipment Fund 9C:

09-A-04C (Tools & Equip.) to 09-A-08C (Auditor & Treasurer Fees)	\$ 350.00
--	-----------

Vote on Motion: Mr. Bates YES, Mr. Glancy YES and Mr. Piros YES.

YES 3NAY 0

Motion Carried.

252-06 Motion by Mr. Glancy, seconded by Mr. Piros to authorize the Fiscal Officer to request an Amended Certificate of Estimated Resources for the following funds:

Fund 10 – Fire District:

Due to additional receipts – INCREASE Certificate an additional		\$86,397.19
Appropriate 10-A-01 (Salaries)	Increase	79,397.19
Appropriate 10-A-04 (Aud. & Treasurers Fee)	Increase	2,000.00
Appropriate 10-A-02 (Empl. Retirement)	Increase	5,000.00

NOVEMBER 06, 2006

Fund 13 – Zoning:

Due to additional receipts – INCREASE Certificate an additional		\$ 2,209.46
Appropriate 13-A-01 (Salaries & Fees)	Increase	2,209.46

Vote on Motion: Mr. Bates YES, Mr. Glancy YES and Mr. Piros YES.

YES 3

NAY 0

Motion Carried.

253-06 Motion by Mr. Piros, seconded by Mr. Bates to approve the minutes of the October 16th meeting.

Vote on Motion: Mr. Bates YES, Mr. Glancy YES and Mr. Piros YES.

YES 3

NAY 0

Motion Carried.

The following correspondence was read by Martha Urchek:

1. Letter from Circuit Court of Barbour County, Alabama regarding Textile Rental Services Litigation.
2. Letter from Trumbull County Commissioners on the acceptance of Stonegate Drainage District.
3. Sprint information on Nextel Walkie-Talkie is eligible for Homeland Security Grants.
4. Sent emails to local newspapers on minutes from last meeting as well as upcoming dates.
5. Meeting notice for October 24th on the District 6 Public Works Integrating Committee – A copy was given to the road department.
6. From Ohio Township News copied article on “New law to assist townships with indigent funerals”.
7. Request from Love Insurance requesting to quote on our property and casualty insurance.

NOVEMBER 06, 2006

8. Memo from Ohio Secretary of State Kenneth Blackwell on the 2006 Issues for the November 06th election.
9. Change in claim reporting procedures through OTARMA.
10. Cable News Insider Flyer from Time Warner Cable.
11. Letter from Trumbull County Planning Commission on relocated McCleary Jacoby Road Dedication Plat.
12. Letter from Darlene St. George on the Fire EMS Services Regional Project. Bazetta's share would be \$4,260.00.
13. Letter from Legal Counsel to Mrs. Mackey on the intersection view obstruction.
14. Letter from Legal Counsel on the township's authority to require Utility Company to move utility lines in township right-of-way.
15. Fax from M-tech Company on their equipment and training.
16. Letter from Trumbull County Engineer John Latell on the acceptance of Stonegate Drive into our road system.
17. Monthly Newsletter of the Ohio Township Association (Grassroots Clippings) which was copied for the trustees.

254-06 Motion by Mr. Piros, seconded by Mr. Glancy to approve purchase orders.
Vote on Motion: Mr. Bates YES, Mr. Glancy YES and Mr. Piros YES.

YES 3

NAY 0

Motion Carried.

After much discussion on the value of the services we are receiving from the City of Warren on the used equipment we purchased from them, the Board decided to withdraw the contract immediately. Mr. Piros said we owe for the services received and should pay them for that portion. Chief Sayers will submit an itemized bill to pay for the services rendered so far this year. Chief Sayers will send a letter to the City of Warren stating the Board's decision to take us off line. Mr. Glancy asked how many officers use these units and the reply was some do and some don't. He said he is working on a countywide system.

NOVEMBER 06, 2006

255-06 Motion by Mr. Piros, seconded by Mr. Glancy to approve payment of bills with the exception of check #4682 in the amount of \$3,045.00 to the City of Warren. Mr. Bates asked the Fiscal Officer to void Check #4682.

Vote on Motion: Mr. Bates YES, Mr. Glancy YES and Mr. Piros YES.

YES 3

NAY 0

Motion Carried.

Ken Flack, State Route 46, asked if the township will be penalized if the contract is broken. Chief Sayers said no.

Road Superintendent Parke:

Road Superintendent Parke was unable to attend due to health reasons.

Police Chief Sayers:

Chief Sayers said he has applications for a part-time police officer and asked if any of the Trustees would like to serve on the committee. Mr. Glancy and Mr. Bates will meet with Chief Sayers on Monday, November 13th at 7:30 PM at the police station to go over the applications.

Chief Sayers said he was re-appointed to the 9-1-1 Review Board for another year. That Board will address various concerns. Mr. Bates asked if our costs could be lowered and the reply was that isn't the Review Board's decision.

Ken Flack asked what percent of coverage we have with officers on the road now. The reply was 80% with two on the 3-11 shift, two on all shifts Friday, Saturday and Sunday, two on the day shift and one on the midnight shift. Mr. Flack was pleased with this as the township has had some problems lately.

Fire Chief McKenzie:

Chief McKenzie had nothing to report.

Mr. Bates asked Chief McKenzie to look into measuring the windows and doors at the two fire stations since Hayco backed out of their bid proposal to replace all the windows and doors at the fire stations. Chief McKenzie said he would do that.

NOVEMBER 06, 2006

Zoning Inspector Mauger:

Mr. Mauger submitted his monthly report to the Board. He passed out pictures to the Board of the structure at 380 State Route 305 that was taken by Justin Bechtel of the Board of Health. The Board of Health has declared this property to be a nuisance and unfit for human habitat.

Mr. Bates asked about the sign on the Robinson's property on McCleary Jacoby Road. The Corp of Engineers approved the plans, but Mr. Robinson hasn't gotten approval for any permits from the Soil and Water per Mr. Mauger. Mr. Bates also suggested Mr. Mauger follow up with Mr. Glancy on the Medzie property. Mr. Glancy said he appreciated that.

256-06 Motion by Mr. Glancy, seconded by Mr. Piros to rescind Resolution 231-06 dated 10-02-06 to Hayco Remodeling to replace windows and doors at Fire Station 11 and 13.

Vote on Motion: Mr. Bates YES, Mr. Glancy YES and Mr. Piros YES.

YES 3

NAY 0

Motion Carried.

257-06 Motion by Mr. Piros, seconded by Mr. Glancy to declare the property at 380 State Route 305 a nuisance.

Vote on Motion: Mr. Bates YES, Mr. Glancy YES and Mr. Piros YES.

YES 3

NAY 0

Motion Carried.

Mr. Bates asked if the house on the Robinson property was approved for burning. Chief McKenzie said all the asbestos has been removed and he sent a letter to Mr. Robinson stating it would be burned down by the end of the month.

Ken Flack asked Mr. Mauger if the township has a fencing regulation and the reply was yes due to the problem of a fence in Timber Creek Heights that spearheaded the fencing law.

Dr. David Brice, Timber Creek North, had a concern about street lights not working, damaged and leaning. He lives on the corner and would like to have another light put in. Mr. Piros asked if he could get him the number on the pole or the nearest address where the light is burned out and he could contact Ohio Edison. As far as putting in another light, that is part of the lighting district and the property owners have to pay for that. Seventy-eight lights were put in and the cost was divided by the homeowners. The township put the funds up front and the money was repaid to the township from the property owners through their property taxes.

NOVEMBER 06, 2006

Mr. Piros said he would come out and take care of reporting the burned out streetlight.

Dr. Brice told the Board where his house is and that two streetlights are very close and one is blocked by a big tree. The streetlights are not spaced evenly. Mr. Piros said Ohio Edison put those streetlights in and had to space them according to the boxes.

Mr. Piros gave a summary of the Timber Creek Heights streetlight project that was put on hold because the homeowners had planted shrubs or mulched around the tap-in boxes. Mr. Piros told Dr. Brice he would come down and look at the streetlights.

Safety Committee:

Chief Sayers reported the next meeting will be Wednesday, December 06th at 9:00 AM at the police station. Mr. Bates asked if the walk thru was done yet and Chief McKenzie said it will be completed by the end of the month. Chief Sayers said the township was reimbursed around \$4,500 because of our participation in the National Safety Council.

Mr. Bates said that while we are on the subject of safety, we should look at changing our Third Party Administrator (TPA) as our present one can't get us in a group rating for next year. This is something the Board should consider next year.

Administration:

Mr. Bates reminded everyone of the office being closed on Tuesday, Election Day, Friday, due to Veteran's Day and also on Thanksgiving Day.

A date of Tuesday, November 14th at 9:00 AM at the administration building was set for the Insurance Committee to go over the bids received from various insurance carriers on the township's health care. Mr. Piros asked Martha to notify the Insurance Committee consisting of two from the Fire Department, Mike Mannella and Kevin Lesh, and two from the Police Department, Mike Hovis and Tom Miller, of the meeting.

258-06 Motion by Mr. Piros, seconded by Mr. Glancy to announce that the Board has read and approved the Road Department contract with the Teamsters Union Local 377 with the correction of the title page with the effective date of 5-1-06 through 4-30-09. At this time the Board signed the contract and asked Martha to mail two copies of the signed contract to the Teamsters Union Representative, Chris Colello.

Vote on Motion: Mr. Bates YES, Mr. Glancy YES and Mr. Piros YES.

NOVEMBER 06, 2006

YES 3
NAY 0
Motion Carried.

Mr. Glancy said the police contract should be forthcoming.

259-06 Motion by Mr. Piros, seconded by Mr. Glancy to rescind Resolution 174-06 on the 10% health care payment from the Board of Trustees.
Vote on Motion: Mr. Bates YES, Mr. Glancy YES and Mr. Piros YES.

YES 3
NAY 0
Motion Carried.

Mr. Piros asked the department heads to stay after to set up for Election Day.

260-06 Motion by Mr. Bates, seconded Mr. Glancy to adjourn the meeting at 8:00 PM.
Vote on Motion: Mr. Bates YES, Mr. Glancy YES and Mr. Piros YES.

YES 3
NAY 0
Motion Carried.

By Motion Adjourned.

A large, stylized handwritten signature in black ink, likely belonging to a board member, is written across the bottom of the page. The signature is cursive and somewhat illegible due to its speed and style.

**BAZETTA TOWNSHIP TRUSTEES REGULAR MEETING
MONDAY, NOVEMBER 20, 2006 AT 7:00 PM**

Present: Jeff Bates, Mike Piros, Bill Glancy and Mark Finamore, Legal Counsel.

Old Business:

Mr. Piros met with Dr. Brice of Timber Creek North regarding the street light problem on November 10th. The light in question is leaning and Mr. Piros reported it to Ohio Edison, Confirmation #709790384. Regarding Dr. Brice's request for an extra light, Mr. Piros informed him that might be a problem but will contact Ohio Edison. The alternative would be for Dr. Brice to place a light off the road right-of-way.

Mr. Piros met with the Insurance Committee on November 14th. They reviewed nine bids and have narrowed it down to two, but are not ready to go forth at this time.

A request was received from Donald Gray, 4705 Warren Road, to pursue annexation into the City of Cortland.

Mr. Glancy and committee interviewed two part-time police officers on November 14th.

He met with Dr. Enyeart and Mr. Migliozi of the Health Department in reference to his neighbor (Medzie) who has garbage and junk cars as there is not much action being done. Mr. Chris Medzie wants to get sewers for the three trailers on his property. The health department didn't know he had three trailers, thought it was for a house only. They can't do anything until one of the trailers is vacant.

Mr. Glancy asked Mr. Mauger about the junk at the corner of State Route 305 and Bazetta Road. The guy selling the produce does not own the property and Mr. Glancy gave Mr. Mauger the name and phone number of the property owner. Something should be done as the neighbors are complaining.

He met with Judge Grendell's husband to make arrangements for a meeting here on the new sewer regulations.

Mr. Piros interjected at this time that he attended a meeting on the new sewage treatment system rules and regulations on November 08th. The rules are lengthy and he suggested that Martha make copies for anyone who might like to review them. The new rules and regulations go into effect on January 01, 2007.

Mr. Bates finished his accident investigation on the police chief's accident on November 13th.

NOVEMBER 20, 2006

Public Participation:

Janet Perhach, Northview Drive, asked about the East Side Sewer and Mr. Piros said according to Mr. Newbrough the easements are in and plans were submitted to the EPA and construction should begin sometime in February/March, 2007. Mrs. Perhach asked Mr. Piros if a contractor has been selected and the reply was no.

Cheryl Tennant, Perkins Jones Road, asked about the Papalas/Miller issue. Mr. Finamore answered that the Trustees called him. Chief Sayers gave his report and no action was taken.

Mrs. Tennant asked if anyone has looked at the landscaping at the gazebo and if the amount of \$7,940 was for the entire project. Mr. Piros said Jeff Mauger submitted a three phase plan and this was Phase 1. He was informed that the park board had given their approval. Mr. Parke said all the planting is done.

Mr. Bud Bowen, State Route 5, said Jeff Mauger is looking for bigger trees.

Mr. Brian Prunty, Storm Water Coordinator for the Trumbull Soil and Water Conservation District presented to the Board four signs that read "Bazetta Township Co-operators with Trumbull Soil and Water Conservation District". Mr. Bates asked Mr. Prunty to give the signs to Mr. Parke to place in high traffic areas for the public to see. Mr. Prunty told the Board that EPA has taken us serious and they will be audited sometime in December. Problems with septic tanks and discharges, we might be fined. He said he is having another workshop and will send a memo to Mr. Parke on the time and place.

August Fauvie, Andrews Drive, asked if the road in Miller Yount Development will be repaired. They need sealed before bad weather. Mr. Parke said it is too late and too wet as the sealer needs to be dry. Mr. Parke said he would like to, but needs to rent a machine. Hopefully we can get it in the spring of 2007.

Al Parana, Andrews Drive, asked about the grant sewer project for Andrews, Janet and Lynn Drives. Mr. Piros said he did pass on to Mr. Newbrough about 14 grants.

Ron Snell, Bazetta Road, asked Mr. Glancy if the health department had a time frame for the Medzie property garbage and the reply was yes, right away within 30 days. They took our inventory and pictures. He mentioned to Mr. Glancy that he thought one of the trailers was vacant. Mr. Glancy said he will contact the health department.

Mr. Mauger said all cars are plated. Mr. Glancy said the pictures that were taken did not show plates on the cars.

NOVEMBER 20, 2006

After much discussion, Mr. Finamore gave a review of three ways to take care of junk cars. He said some townships have had Bud's Towing come in and take the junk cars away at no cost for the salvage of the parts and A-1 Hauling will come in and take pictures of the garbage pile and then haul it away for a small fee that can be placed on the homeowners taxes.

261-06 Motion by Mr. Piros, seconded by Mr. Glancy that the Medzie property with garbage and junk cars is a nuisance. Mr. Finamore is to send a letter to have the garbage and junk cars removed within 7 days or Bud's Towing will remove the junk cars and A-1 Hauling will remove the garbage.

Vote on Motion: Mr. Bates YES, Mr. Glancy YES and Mr. Piros YES.

YES 3

NAY 0

Motion Carried.

Mr. Finamore said the trustees have the authority and Mr. Glancy said if it is our business, why do we need zoning.

Mr. Parke wanted to know if the Board wanted him to mow the grass and Mr. Bates said yes. Mr. Parke will have a police officer present.

Mr. Bowen questioned why our legal counsel didn't give the Board the authority before as this could have been cleared up months ago. Isn't Mr. Finamore on the township's payroll?

Mr. Glancy said he relied on the police and zoning.

262-06 Motion by Mr. Piros, seconded by Mr. Glancy to approve the minutes of the November 06th meeting.

Vote on Motion: Mr. Bates YES, Mr. Glancy YES and Mr. Piros YES.

YES 3

NAY 0

Motion Carried.

The following correspondence was read by Martha Urchek:

1. Weekly update from Ohio Township Association.
2. Trumbull County Board of Health Agenda for November 15th meeting and minutes from their regular meeting held on October 18th.

NOVEMBER 20, 2006

- 3. Letter from Geauga-Trumbull Solid Waste Management District regarding the Christmas Tree Collection and Recycling Grant Application.
- 4. Letter from Mill Creek Metro Parks on the Alliance for Watershed Easements information seminar in Canfield on November 28th.
- 5. Letter from State Employment Relations Board on a Clearing House that soon will be accessible to all public employers.
- 6. Letter from the trustees was sent to Howland Township (Attention Mrs. St. George) informing them we will no longer be a participant in the Fire/EMS consolidation dialogue.
- 7. Received quote for office supplies from DeBald Company out of Youngstown.
- 8. Received information for the Winter Conference January 31st – February 03, 2007 in Columbus.
- 9. Sent fax to the Tribune for a Work Session following tonight’s meeting.
- 10. Letter from Donald E. Gray, 4705 Warren Road NE, pursuing the annexation of one acre of his property to Cortland City.

263-06 Motion by Mr. Piros, seconded by Mr. Glancy to approve purchase orders.
 Vote on Motion: Mr. Bates YES, Mr. Glancy YES and Mr. Piros YES.

YES 3
 NAY 0
 Motion Carried.

264-06 Motion by Mr. Bates, seconded by Mr. Piros to approve payment of bills.
 Vote on Motion: Mr. Bates YES, Mr. Glancy YES and Mr. Piros YES.

YES 3
 NAY 0
 Motion Carried.

Police Chief Sayers:

Tom Miller sitting in for Chief Sayers said the Chief would like a work session with the Board on the Chief’s return to work date sometime after December 05th. A work session with the police chief is scheduled for Monday, December 11th at 8:00 AM at the police station.

NOVEMBER 20, 2006

Mr. Bates asked Martha to place this in the Tribune.

Fire Chief McKenzie:

265-06 Motion by Mr. Piros, seconded by Mr. Glancy to approve the Ambulance and Fire Service fees and charges with Ohio Billing starting January 01, 2007.

Vote on Motion: Mr. Bates YES, Mr. Glancy YES and Mr. Piros YES.

YES 3

NAY 0

Motion Carried.

Mr. Piros asked if the residents will be charged if their insurance provider does not pay the entire bill, and Chief McKenzie said only non-residents will be charged. No residents will be charged, just like it is now.

266-06 Motion by Mr. Piros, seconded by Mr. Glancy to approve the Business Associate Agreement with Ohio Billing starting January 01, 2007.

Vote on Motion: Mr. Bates YES, Mr. Glancy YES and Mr. Piros YES.

YES 3

NAY 0

Motion Carried.

267-06 Motion by Mr. Piros, seconded by Mr. Glancy to approve the Service Agreement with Ohio Billing starting January 01, 2007.

Vote on Motion: Mr. Bates YES, Mr. Glancy YES and Mr. Piros YES.

YES 3

NAY 0

Motion Carried.

268-06 Motion by Mr. Piros, seconded by Mr. Bates to hire UCB Collection Agency of Cleveland to collect the fees.

Vote on Motion: Mr. Bates YES, Mr. Glancy YES and Mr. Piros YES.

YES 3

NAY 0

Motion Carried.

NOVEMBER 20, 2006

Mr. Bates asked what are their fees and Chief McKenzie said they will receive 25% of any debt it collects and 35% if a case goes to court.

269-06 Motion by Mr. Piros, seconded Mr. Glancy to sell the old Hurst Rescue Tool.

Vote on Motion: Mr. Bates YES, Mr. Glancy YES and Mr. Piros YES.

YES 3

NAY 0

Motion Carried.

Mr. Glancy asked what it will sell for and the reply was approximately \$4,000. Mr. Glancy would like to know who we sell it to and the price. Chief McKenzie will comply with that request.

Steve Perhach, Northview Drive, asked if the only times we will need UCB is if there is a non-resident who does not pay and the reply was yes by Chief McKenzie.

Road Superintendent Parke:

270-06 Motion by Mr. Glancy, seconded by Mr. Bates to purchase from Dexter Company an extra set of snow plow blades and bolts at a cost of \$850.

Vote on Motion: Mr. Bates YES, Mr. Glancy YES and Mr. Piros YES.

YES 3

NAY 0

Motion Carried.

Mr. Parke asked the Board if the low spot on Cadwallader-Sonk Road could be repaired with hot mix. Mr. Piros said he agreed that it is very low and an accident could happen.

271-06 Motion by Mr. Piros, seconded by Mr. Bates to have the low spot on Cadwallader-Sonk Road repaired. The cost is not to exceed \$3,000.

Vote on Motion: Mr. Bates YES, Mr. Glancy YES and Mr. Piros YES.

YES 3

NAY 0

Motion Carried.

Mr. Parke will contact Rick Hutton of Cortland Excavating to hot patch the low spot as he had sent in a previous quote some months ago for approximately \$2,600.

NOVEMBER 20, 2006

Mr. Parke also asked about the tree on the Mackey property. Mr. Finamore sent her a letter and she trimmed the wrong tree. Mr. Bates suggested since there are no leaves on the tree at the present that Mr. Parke address this issue in the spring.

Mr. Parke asked about the sewers on Lynn Drive. Mr. Piros hasn't heard anything on this.

Mr. Parke said the problem he had on McCleary Jacoby Road will not happen again. Mr. Parke will finish with this project in the spring.

Al Parana asked Mr. Parke about the dip in the road at Bazetta Road and Perkins-Jones. Mr. Parke will contact the Trumbull County Engineer's office. Mr. Piros asked Mr. Parke to ask Chris Connelly about the water problems on Lakeshore Drive at the Art Racco's property. Mike Sliwinski owes us a report as to what needs to be done.

Mr. Parke informed the Board about Issue 2 – we are in the middle loan part and we are on the bubble. We could lose it.

Administration:

The public was reminded that the administration office will be closed on Wednesday, November 22nd through Friday, November 24th. It was suggested that since the police station will have a secretary on duty that all calls be forwarded to the police station and a sign put on the door that the office will be closed.

272-06 Motion by Mr. Piros, seconded by Mr. Bates to authorize the Fiscal Officer to request a new Certificate of Estimated Resources to reduce Fund 14 (Fire Fighters Assistant Grant) by \$1,000.

Vote on Motion: Mr. Bates YES, Mr. Glancy YES and Mr. Piros YES.

YES 3

NAY 0

Motion Carried.

Motion to pick up PERS contribution was tabled.

273-06 Motion by Mr. Piros, seconded by Mr. Glancy that after reviewing the police contract that the contract be approved and needed the Board signatures.

Vote on Motion: Mr. Bates YES, Mr. Glancy YES and Mr. Piros YES.

NOVEMBER 20, 2006

YES 3

NAY 0

Motion Carried.

274-06 Motion by Mr. Piros, seconded by Mr. Bates to go into executive session to discuss possible employee discipline at 8:12 PM.

Vote on Motion: Mr. Bates YES, Mr. Glancy YES and Mr. Piros YES.

YES 3

NAY 0

Motion Carried.

At this time, it is to be noted that Mr. Glancy left at 8:15 and was not present for the executive session.

275-06 Motion by Mr. Bates, seconded by Mr. Piros to return to regular session from the executive session at 8:33 PM.

Vote on Motion: Mr. Bates YES, and Mr. Piros YES.

YES 2

NAY 0

Motion Carried.

Mr. Finamore said that since Mr. Glancy went home sick, it was not proper to take any action and will reconvene at the next meeting on the possible employee discipline.

Mrs. Tennant asked Mr. Bates if he read the book on the police officer incident. Mr. Bates said he read the summary. Since Mrs. Tennant read it three times, she suggested that all the trustees read the book.

Special Agent Bansky went to OPERS to have them show him the file. Officer Miller said he has the original paper. Wouldn't you think if you had the original paper, you would guard it with your life?

Mrs. Tennant went on to say the grand jury didn't bill it. She suggested to the board to clean your house.

Remember we had problems with the police department as well as the fire department in the past.

Mr. Piros said all parties will have input in it.

NOVEMBER 20, 2006

She asked the two of them to please read the book and discipline where needed.

Mr. Finamore said he will read the book.

Mr. Bates said since all three Board members are not here, the work session scheduled for tonight is cancelled.

276-06 Motion by Mr. Bates, seconded by Mr. Piros to adjourn the meeting at 8:40 PM.
Vote on Motion: Mr. Bates YES and Mr. Piros YES.

YES 2

NAY 0

Motion Carried.

By Motion Adjourned.



A SERVICE AGREEMENT

For:
Collection Services

For:
Bazetta Fire Department

By:
UNITED COLLECTION BUREAU, INC.
November 9, 2006

AGREEMENT FOR COLLECTION SERVICES

This agreement is made as of this 9TH day of November, by and between UNITED COLLECTION BUREAU, INC. ("UCB"), 5620 SOUTHWYCK BLVD., SUITE 206, TOLEDO, OH and THE BAZETTA FIRE DEPARTMENT ("CLIENT").

WITNESSETH

CLIENT and UCB in consideration of this agreement agree as follows:

1. SERVICE TO BE PROVIDED

UCB will provide CLIENT with Recovery Services on accounts that CLIENT submits to UCB.

2. TERM

This Agreement shall commence on November 9, 2006 and shall continue for one (1) year ending November 8, 2007. This Agreement shall be automatically renewed for successive one-year periods upon the same terms and conditions contained in this Agreement, or upon such other terms and conditions to which the parties mutually agree in writing, unless and until terminated as described below.

3. SUBMISSION AND RECOVERY OF ACCOUNTS

CLIENT will submit accounts to UCB for collection efforts through its Primary and Legal Collections Program. CLIENT agrees to submit said accounts via password protected 3 1/2" diskette, hard copy paper, secure FTP transmission or encrypted email submissions. UCB will exert active and continuous collection efforts in accordance with lawful practices during the entire period such accounts are held by UCB. The information provided by CLIENT will be for the sole purpose of providing services as delineated in paragraph 1 of this agreement.

4. HANDLING OF FUNDS

CLIENT agrees to provide UCB with information of all direct payments on accounts submitted to UCB and will investigate their records to assure UCB is notified of such direct payments within 30 days of receipt.

5. FEES FOR SERVICE

UCB agrees to provide recovery and/or collection services on accounts assigned by CLIENT. The pricing for the Primary Collections Phase will be at the contingency rate of 25% and Legal Collections will be at the contingency rate of 35%. In this pricing structure, UCB will forward all court costs.

6. UCB'S MONTHLY STATEMENT AND METHOD OF PAYMENT

On those accounts in which a contingency rate applies, UCB agrees not later than the 10th day of each month to supply CLIENT a statement of all monies collected during the prior month as follows:

- A. All amounts collected by UCB.
- B. All amounts paid directly to CLIENT together with a check drawn to CLIENT for all monies due, less commission. UCB's fee is due within 30 days of receipt of Invoice.

7. COMPLIANCE WITH LAW: OBSERVANCE OF ETHICAL PRACTICES

UCB agrees that all its activities shall comply with federal, state, and local laws, regulations, and rules.

8. TERMINATION OF AGREEMENT

This agreement shall be effective on the date first set forth above and shall continue in effect until terminated as herein after provided. Either party may terminate this agreement by giving the other party at least sixty (60) days prior written notice of the date of termination. Any notices required shall be in writing and shall be deemed to have been properly given in writing and sent by mail, in care of CLIENT, and in the care of UCB, Sam Rickard, President. Provided, however, that either party may terminate this agreement immediately in the event that (a) the other party has violated any of the terms or provisions hereof, or (b) the other party files a petition for relief under 11 U.S.C. or a permanent receiver is appointed for the other party's property and the receiver or petition is not removed or dismissed within 60 days after appointment for filing; or if (whether voluntarily or involuntarily) the other party takes advantage of any debtor relief proceeding under any present or future laws; or if the other party makes an assignment for the benefit of creditors.

9. INDEMNITY

UCB shall hold harmless and indemnify CLIENT and its trustees, officers, and employees from and against any claims, loss, expense, suits, or damages including reasonable attorney fees, expenses, and court costs arising out of or due to the alleged improper conduct of UCB in its collection efforts. Should any such claims arise, CLIENT shall give notice to UCB in writing within a reasonable time not to exceed ten (10) days and forward to UCB any such demand, notice, summons, or other process received by CLIENT. Likewise, CLIENT shall hold harmless and indemnify UCB and its trustees, officers, and employees from and against any claims, loss, expense, suits, or damages including reasonable attorney fees, expenses, and court costs arising out of or due to the alleged improper conduct of CLIENT. Should any such claims arise, UCB shall give notice to CLIENT in writing within a reasonable time not to exceed ten (10) days and forward to CLIENT any such demand, notice, summons, or other process received by UCB.

10. FINAL AGREEMENT

This agreement contains the entire agreement between the parties hereto and no modification, alteration, or amendment thereof shall be binding of the parties hereto unless it is in writing and signed by both parties.

UNITED COLLECTION BUREAU, INC.

By

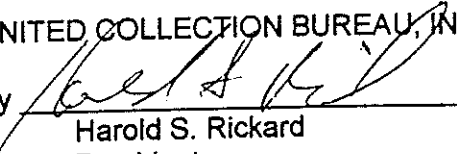
Harold S. Rickard
President

BAZETTA FIRE DEPARTMENT

By

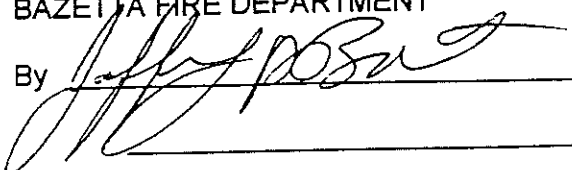

OHIO BILLING, INC. SERVICE AGREEMENT

This Agreement is entered into this 30 day of November, 2006 by and between Bazzetta Township Fire Department (Provider) and Ohio Billing, Inc. (Ohio Billing).

RECITALS

- A. Provider currently provides emergency medical services and requires service to process, bill, and collect its accounts receivable.
- B. Ohio Billing, Inc. is an independent billing service which possesses the expertise and facilities to provide such services to the Provider and has agreed to do so under the terms set forth hereinafter.

NOW THEREFORE, in consideration of the mutual promises of the parties, it is hereby agreed that:

- 1. Services. Provider request Ohio Billing, Inc. agrees to provide the exclusive billing automated computerized accounts receivable system for the billing and collection of the accounts of Provider. Ohio Billing, Inc. shall be further responsible for the preparation and filing of insurance reports and claims in connection with the collection of said accounts.
- 2. The parties agree that Ohio Billing, Inc. shall be exclusively responsible for the hiring and training of competent personnel and the supervision thereof.
- 3. Patient Information. Provider agrees to provide Ohio Billing, Inc. with such information, as may be reasonably necessary to permit the performance of the services described above on a regular basis.
- 4. Ohio Billing, Inc. acknowledges and agrees that all such information given to Ohio Billing, Inc. is confidential and Ohio Billing, Inc. further agrees to instruct its employees concerning the confidential nature of this information.
- 5. Reports. Ohio Billing, Inc. agrees to submit to Provider reports on the status of accounts receivable on a monthly basis for the prior month's activities.
- 6. Collections. Ohio Billing, Inc. will bill and provide reminder billing per account if necessary for up to 120 days. Accounts not paid thereafter will be returned to Provider or the collection agency selected by Provider. Provider will provide weekly reports to Ohio Billing, Inc. on all amounts collected by Provider from billings by Ohio Billing, Inc..
- 7. Fees. For providing the above described services, Provider agrees to pay Ohio Billing, Inc. by the tenth day of the following month \$21.00 for each EMS, MVA run processed by Ohio Billing, Inc.; and one-time set-up fee of \$795 due on signing.
- 8. Relationship of Parties. The parties agree that Ohio Billing, Inc. is an independent contractor and that neither it nor its employees are employees or agents of Provider, and neither party shall be liable for any obligations or liabilities incurred by the other.

7. Compliance. The parties acknowledge and agree that Ohio Billing, Inc. is principally responsible for compliance and makes all decisions on coding for billing and reporting purposes. Ohio Billing, Inc. represents to Provider that it has a current compliance program. Ohio Billing, Inc. agrees that it will perform periodic internal audits and report the results of such audits to Provider.

Ohio Billing, Inc. and Provider agree that they will immediately inform the other in the event they become aware of any audit or investigation by outside parties concerning the professional services of Provider or the billing for such services. The parties agree to mutually cooperate with each other in connection with any such audit or inquiry.

Ohio Billing, Inc. further agrees to cooperate with Provider in connection with any requests by Provider for an external review or audit of coding and billing procedures by Ohio Billing, Inc. which such audit or review to be at the expense of Provider.

8. Term. This Agreement is for a period of 24 months commencing on 1/1/07, but may be terminated by either party upon 60 days prior notice. The Agreement will automatically renew unless terminated. In the event of termination, unless otherwise requested by Provider, Ohio Billing, Inc. shall suspend any further activity on any unpaid accounts. Ohio Billing, Inc. shall provide a final report of activity after termination.

9. Records. At the conclusion of this Agreement, Ohio Billing, Inc. will make any paper or electronic records, which came from Provider available to Provider for pick-up. However, Provider agrees that Ohio Billing, Inc. may hold any records pending payment of any outstanding invoices and that Ohio Billing, Inc. may charge reasonable fees for the transfer of any paper or electronic records to Provider.

Further, Provider agrees that any electronic records or paper records created by Ohio Billing, Inc. are independent work product, and are owned by Ohio Billing and Provider waives any property right thereto. Ohio Billing, Inc. may, at its discretion, sell such work product to Provider at a cost to be determined by Ohio Billing, Inc.. Ohio Billing, Inc. will not retain records of Provider after termination of this Agreement.

10. Additional Documents. Provider agrees to sign such documents as may be reasonably required to enable Ohio Billing, Inc. to perform its obligations under this Agreement.

11. Breach. In the event of any breach by Provider, Ohio Billing, Inc. may suspend services until Provider cures its breach. In the event of any breach by Ohio Billing, Inc., Provider will give Ohio Billing, Inc. written notice and Ohio Billing, Inc. will have thirty (30) days to cure its breach.

12. Entire Agreement. This document expresses the entire Agreement between the parties and shall be construed under the laws of Ohio.

Handwritten signature

IN WITNESS WHEREOF, the parties have signed this Agreement effective the date above first written.

Bazetta Township Fire Department

773 Everett Hill Road

Coyland, Ohio 44414

[Signature]

Robert A. Bates, Trustee - Chairman

[Signature]

Michael G. Pirog, Trustee - Vice Chairman

[Signature]

William O. Glancy, Trustee

[Signature]

Martha Urcheck, Financial Officer

[Signature]

PROVIDER/Title

Ohio Billing, Inc.
P.O. Box 515
358 Edgebrook NE
Bolivar, Ohio 44612

By: *[Signature]* 12/17/06
President

**BAZETTA TOWNSHIP TRUSTEES REGULAR MEETING
MONDAY, DECEMBER 04, 2006 AT 7:00 PM**

Present: Jeff Bates, Mike Piros, Bill Glancy and Mark Finamore, Legal Counsel.

Old Business:

Mr. Piros reported to Ohio Edison about a street light on the corner of State Route 5 and Timberline. Ohio Edison's work order number is #112906015627. He also mentioned to Ohio Edison that a resident reported this outage months ago.

Regarding the "leaned" streetlight pole near Dr. Brice's house on Timber Creek North, Mr. Piros reported it has been repaired. After reviewing the Ohio Edison design, placing another streetlight near Dr. Brice's residence is not feasible as there is no near-by tap in. He informed Dr. Brice that he could put a light on his property.

Mr. Bates remarked it is very dark at that corner.

Mr. Parke said he had the police department do an inventory of burned out street lights.

Mr. Glancy had nothing to report.

Mr. Bates said a meeting at 8:00 PM tonight for a grievance from the road department had to be rescheduled due to a conflict with their representative.

Another date was set for Monday, December 11th at 9:30 AM at the administration building to discuss this grievance. The work session with Chief Sayers is still scheduled for 8:00 AM on Monday, December 11th at the police station.

At this time Mr. Bates informed the Board that his work schedule has been changed effective December 11th. The new schedule is 11:00 AM until 8:00 PM.

Mr. Piros asked if there would be a conflict with our evening meetings and the reply was no. Mr. Bates asked Martha to place an ad in the newspaper for the work session with the police chief, but not for the grievance meeting.

Mr. Bates said after investigating the accident to Chief Sayers, he showed the Board pictures of ladders. These pictures were given to Chief McKenzie who will show them to the Safety Committee at their meeting on Wednesday, December 06th at 9:00 AM at the police station.

DECEMBER 04, 2006**Public Participation:**

Cheryl Tennant, Perkins Jones Road, asked about the Papalas/Miller matter and Mr. Bates replied the Board is going into executive session tonight to further discuss it.

The following correspondence was read by Martha Urchek:

1. Email from Darlene St. George regarding the Ohio House of Representatives will be considering bills. One bill in particular is HB-400 requiring townships and counties to permit mining in all zoned areas as either a permitted or conditional use. Ohio Township Association is opposed to the bill.
2. Email from Regional Chamber on the Smoke Free Workplace Act, which will take effect on December 08th banning smoking in all workplaces.
3. Announcement from the Ohio Department of Transportation on John Avery being named the Interim Deputy Director of ODOT District 4.
4. Received letter from Coca Cola Enterprises removing commission on existing machines that generate less than 75 cases per year. Our commission last year was \$41.58.
5. Letter from the Trumbull County Planning Commission on the Replat Lots 40, 41, 60 and 61 in the Lakeshore Allotment sewage upgrade. A meeting will be held at 9:00 AM on December 12th.
6. Received a letter from Mark Finamore on his response to SERB (State Employment Relations Board) on the Amendment of Certification filed by the Fraternal Order of Police, Ohio Labor Council.
7. Letter from EPA on the public hearing for WCI Furnace Replacement.
8. Certification from the Trumbull County Commissioners on the acceptance of Stonegate Drive.
9. Certification from the Trumbull County Commissioners on the acceptance maintenance bond for Stonegate Plat No. 1.
10. Letter from the Trumbull County Engineer on the Annual ODOT Mileage Certification.
11. Received request from Niles Mayor to join the Niles Trumbull Transit System at a cost of .50 per citizen (6306 X .50 is \$3,153).

DECEMBER 04, 2006

277-06 Motion by Mr. Piros, seconded by Mr. Bates to approve the transfer by Fiscal Officer Urchek on 11-21-06 from 05-A-13 Cemetery (Unemployment Compensation) to 05-A-90 Cemetery (FICA/Medicare Employer Share) \$100 to make payroll.

Vote on Motion: Mr. Bates YES, Mr. Glancy YES and Mr. Piros YES.

YES 3

NAY 0

Motion Carried.

278-06 Motion by Mr. Piros, seconded by Mr. Glancy to authorize the Fiscal Officer to transfer within the following:

From 01-A-26 General (Other Expenses) to 01-F-01A Salaries – Groundskeeper \$500.00

From 01-A-26 General (Other Expenses) to 01-A-16 General Health \$20.00

From 01-A-26 General (Other Expenses) to 01-C-07 Fire (Repairs) \$841.55

From 04-A-02 Road (Employer's Retirement) to 04-A-10 Road (Insurance) \$700.00

From 04-B-01 Road (Salaries) to 04-A-10 Road (Insurance) \$6,210.00

From 05-A-03 Cemetery (Employer's Retirement) to 05-A-01 Cemetery (Mowing) \$3,500.00

From 09-A-02 Police (Employers' Retirement) to 09-A-01D Police Salary (Mechanic) \$3,500.00

From 01-A-04 Administration (Supplies) to 01-A-06 Administration (Insurance) \$200.00

Vote on Motion: Mr. Bates YES, Mr. Glancy YES and Mr. Piros YES.

YES 3

NAY 0

Motion Carried.

279-06 Motion by Mr. Glancy, seconded by Mr. Bates to authorize the Fiscal Officer to request a new Amended Certificate of Estimated Resources for the following:

Fund 10 – Fire District

Due to additional receipts – INCREASE Certificate an additional \$23,865.38

Fund 10 -- Fire District

Appropriate 10-A-01 (Salaries)	INCREASE	\$17,365.38
--------------------------------	----------	-------------

Appropriate 10-A-02 (Empl. Retire)	INCREASE	\$ 6,500.00
------------------------------------	----------	-------------

Vote on Motion: Mr. Bates YES, Mr. Glancy YES and Mr. Piros YES.

YES 3

NAY 0

Motion Carried.

DECEMBER 04, 2006

Mr. Piros commented on one of the correspondence items on the Niles Transit Transportation System (NiTTS). It is a nice service to give to our senior residents to come to Wal-Mart, the Dialysis Center and Forum Health on Elm Road. This is a good way to give back to our residents. After much discussion the following motion was made.

280-06 Motion by Mr. Glancy, seconded by Mr. Piros to approve the minutes of the November 20th meeting.

Vote on Motion: Mr. Bates YES, Mr. Glancy YES and Mr. Piros YES.

YES 3

NAY 0

Motion Carried.

281-06 Motion by Mr. Glancy, seconded by Mr. Piros to join NiTTS for one year starting with January at a cost of \$3,153.

Vote on Motion: Mr. Bates ABSTAINED, Mr. Glancy YES and Mr. Piros YES.

YES 2

ABSTAINED 1

Motion Carried.

282-06 Motion by Mr. Bates, seconded by Mr. Glancy to approve purchase orders.

Vote on Motion: Mr. Bates YES, Mr. Glancy YES and Mr. Piros YES.

YES 3

NAY 0

Motion Carried.

283-06 Motion by Mr. Piros, seconded by Mr. Glancy to approve payment of bills.

Vote on Motion: Mr. Bates YES, Mr. Glancy YES and Mr. Piros YES.

YES 3

NAY 0

Motion Carried.

Fire Chief McKenzie:

Chief McKenzie had nothing to report.

DECEMBER 04, 2006**Road Superintendent Parke:**

Mr. Parke submitted his monthly report.

Mr. Parke asked the Board to pass a resolution for the snow ban to go into effect immediately, December 04th.

284-06 Motion by Mr. Piros, seconded by Mr. Glancy to pass a resolution for the snow ban to go into effect immediately, December 04th.

Vote on Motion: Mr. Bates YES, Mr. Glancy YES and Mr. Piros YES.

YES 3

NAY 0

Motion Carried.

YES 3

NAY 0

Motion Carried.

Mr. Parke will post the "emergency snow route signs" tomorrow, December 05th.

Mr. Parke also said he will call the Trumbull County Engineer's Office regarding their mileage for the township is wrong as we now have Stonegate. He will have this information before the December 18th meeting.

Mr. Finamore replied that Hubbard Township has the most miles – 74 miles to be exact.

Mr. Parke said that since the wind last Friday took down a lot of trees, he would like to purchase a new Stihl chain saw from Cortland Tractor for \$279.95 to be taken out of supplies.

285-06 Motion by Mr. Piros, seconded by Mr. Glancy to approve the purchase of a Stihl chain saw from Cortland Tractor for \$279.95 which is taken out of supplies.

Vote on Motion: Mr. Bates YES, Mr. Glancy YES and Mr. Piros YES.

YES 3

NAY 0

Motion Carried.

Mr. Parke further stated that there is a big tree down in the township park, but the ground is too soft and will take care of when the ground freezes.

DECEMBER 04, 2006

Work session with the Fiscal Officer following tonight's meeting.

There was a reminder of the Tree Lighting Ceremony at the township park on Sunday, December 10th at 6:00 PM with refreshments to follow at the administration building.

289-06 Motion by Mr. Piros, seconded by Mr. Glancy to reduce current OPERS percentage from 9% to 7% on Frank Parke due to new road department contract effective first pay in December, 2006.

Vote on Motion: Mr. Bates YES, Mr. Glancy YES and Mr. Piros YES.

YES 3

NAY 0

Motion Carried.

290-06 Motion by Mr. Piros, seconded by Mr. Glancy to go into executive session at 7:45 PM to discuss possible employee discipline.

Vote on Motion: Mr. Bates YES, Mr. Glancy YES and Mr. Piros YES.

YES 3

NAY 0

Motion Carried.

291-06 Motion by Mr. Bates, seconded by Mr. Glancy to return to regular session at 8:35 PM.

Vote on Motion: Mr. Bates YES, Mr. Glancy YES and Mr. Piros YES.

YES 3

NAY 0

Motion Carried.

At this time, Mr. Bates asked Legal Counsel to respond.

Mr. Finamore said the trustees asked him to convey the facts from the review by Chief Sayers that no further action is taken and the matter is closed.

Cheryl Tennant asked if she could make one comment. She asked that the big book, the prosecuting attorney's review, the BCI nor the report from OPERS meant nothing – not one thing. She said she knew how Mr. Glancy voted.

Mr. Finamore said the case is closed.

That's fine," replied Mrs. Tennant.

DECEMBER 04, 2006

292-06 Motion by Mr. Glancy, seconded by Mr. Piros to adjourn the meeting at 8:38 PM.
Vote on Motion: Mr. Bates YES, Mr. Glancy YES and Mr. Piros YES.

YES 3

NAY 0

Motion Carried.

By Motion Adjourned:

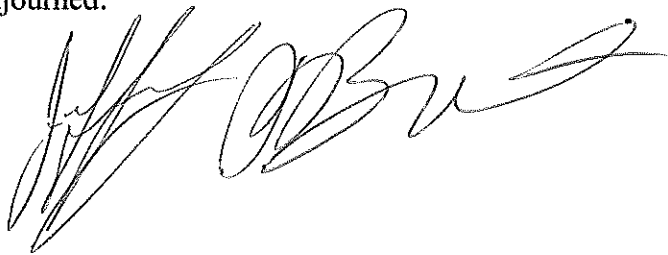
A handwritten signature in black ink, appearing to be "John A. Bates", written over the text "By Motion Adjourned:". The signature is cursive and somewhat stylized.

**WORK SESSION WITH FISCAL OFFICER
MONDAY, DECEMBER 04, 2006 AT 8:56 PM**

Present: Trustees Bates, Piros, Glancy and Legal Counsel, Mark Finamore.

Set End of the Year Meeting for December 28th at 9:00 AM at the administration building.

Set the following dates:

Cut off for all spending for December 20, 2006.

All invoices and bills are to be in the Fiscal Officer's office by 11:00 AM on December 21, 2006.

All purchase orders and blanket certificates to be closed on December 29th with a date of December 31st and re-open new ones effective January 01, 2007.

The final date for receipting money will be December 28th. All receipts for money/checks need to be in the Fiscal Officer's office by 11:00 AM on December 28th.

Re-organizational meeting scheduled for Tuesday, January 02, 2007, at 7:00 PM at the administration building.

There was a discussion on the road department contract.

Approved Vivian to help Robyn with the transition for the GASB software for Saturday, December 09th and discussed consulting work for Vivian on back pay for an employee.

**BAZETTA TOWNSHIP TRUSTEES REGULAR MEETING
MONDAY, DECEMBER 18, 2006 AT 7:00 PM**

Present: Jeff Bates, Mike Piros, Bill Glancy and Mark Finamore, Legal Counsel.

Mr. Bates opened the meeting by stating the agenda will be altered a little. He further stated the Board of Trustees changed the Re-organizational Meeting on January 02, 2007 from 7 PM to 8 AM at the administration building.

At this time, Mr. Piros recognized three employees who have shown exemplar dedication and have gone above and beyond the call of duty. Kris Parke, Road Department, has written grants for Issue II as well as for the Geauga-Trumbull Solid Waste District, Dennis Lewis, Fire Department, has written various grants from Ohio EMS to Firefighter Assistance while Police Chief Chuck Sayers has written many grants for Homeland Security. In the last five years, these three individuals have written grants that total over \$506,000.00 and eliminating the township to go and ask our residents for money. They all have gone the extra mile in writing these grants. A letter of distinction and a certification of appreciation were presented to Kris Parke by Mr. Bates, to Chuck Sayers by Mr. Glancy and to Dennis Lewis by Mr. Piros.

Mr. Glancy stated he wants to set up a program where these three individuals can help other departments in writing grants.

Old Business:

Mr. Piros said he received a phone call from a Howland-Wilson Road resident who expressed his thanks for a job well done on the cleaning of ditches. Mr. Piros passed this appreciation on to Mr. Parke.

The street light at the corner of State Route 5 and Timberline has been repaired. Mr. O'Brian from Ohio Edison called him regarding the Timber Creek Heights Lighting District. Mr. Piros informed him that the bids were rejected and the township will go out for bids to include everything as one package after the first of the year.

Mr. Glancy praised Mr. Mauger in getting the property at the corner of State Route 305 and Bazetta Road cleaned up. Mr. Glancy had received calls from residents on this property.

The three trustees had a work session with Police Chief Sayers and felt it was very productive.

Mr. Glancy further stated that a big dog had been attacked by a bear on Portage-Easterly. This was verified by a vet. He wants the public to be aware of this.

Chief Sayers said his office was notified of a coyote in the Howland-Wilson area. He also stated anyone seeing a bear, coyote or any suspicious animal to call 9-1-1 right away.

DECEMBER 18, 2006

Mr. Bates asked the Safety Committee if the 4-Step-Stop-Step Ladder had a weight capacity and Fire Chief McKenzie replied the step ladder had a 300# limit. Chief McKenzie also stated the Safety Committee did a thorough research and this was the best way to go. Chief Sayers will write a purchase order to Step Stool Store in the amount of \$318.00 after the first of the year.

Mr. Bates asked Chief McKenzie about the walk-thru inspections and the reply was they will be done by the end of next week or maybe the first week in 2007 with a copy to the trustees.

Mr. Bates said any and all accidents/any near missies are to be reported to the Board so we can comply with OSHA.

Mr. Piros said that on December 4th the Board approved to go with the Trumbull Transit System and a Press Release will be sent to the Tribune to notify the residents. Again this is for the disabled or 62 years or older at a cost of \$2 for one way. The Board will re-evaluate after a one year trial period.

Public Participation:

There was nothing.

293-06 Motion by Mr. Piros, seconded by Mr. Glancy to authorize the Fiscal Officer to transfer within the following funds:

Fire Fund 10:

10-A-15 (Other Expenses) to 10-A-14 (Insurance) \$190.00
10-A-14-A (Contracts) to 10-A-14 (Insurance) \$100.00
10-A-09 (Supplies) to 10-A-14 (Insurance) \$1,400.00
10-A-01B (Salary – Mech.) to 10-A-14 (Insurance) \$125.35
10-A-11 (Training) to 10-A-01A (Salary PT) \$555.00
10-A-11 (Training) to 10-A-09 (Supplies) \$750.00

Vote on Motion: Mr. Bates YES, Mr. Glancy YES and Mr. Piros YES.

YES 3

NAY 0

Motion Carried.

DECEMBER 18, 2006

294-06 Motion by Mr. Bates, seconded by Mr. Glancy to authorize the Fiscal Officer to request an Amended Certificate of Estimated Resources from Fire Fund 10 as follows:

Additional Receipts	\$ 8,877.36
Advance from General Fund 1	\$33,670.00
Total additional receipts:	\$42,547.36

The additional receipts will be appropriated as follows:

10-A-01 -- Fire Supplies	\$20,670.00
10-A-02 -- Fire (Employers Retire Contribution)	\$13,000.00
10-A-01A -- Fire (Part-Time)	\$ 8,877.36

Vote on Motion: Mr. Bates YES, Mr. Glancy YES and Mr. Piros YES.

YES 3

NAY 0

Motion Carried.

295-06 Motion by Mr. Piros, seconded by Mr. Bates to authorize the Fiscal Officer to transfer within funds the following:

General Fund 1:

01-H-06 (Contracts) to 01-A-17 (Transfers) to \$1,000.00
 01-A-01 (Trustees – Salary) to 01-A-17 (Transfers) \$2,362.00
 01-A-02 (Clerk – Salary) to 01-A-27 (Transfers) \$990.00
 01-A-26 (Other) to 01-A-27 (Transfers) \$15,000.00
 01-A-28 (Adm. & Sec. Salary) to 01-A-27 (Transfers) \$5,000.00
 01-A-12 (Employers Retire.) to 01-A-27 (Transfers) \$5,000.00

Cemetery Fund 5:

05-A-03 (Employers Retire) to 05-A-01 (Salary – Mowing) \$1,000.00
 05-A-07 (Repairs & Maint.) to 05-A-09 (Supplies) \$500.00

Police Fund 9:

09-A-01 (Salary) to 09-A-01B (Salary PT) \$2,000.00

Park Fund 01:

01-F-07 (Repairs & Maint.) to 01-F-06 (Supplies) \$200.00

DECEMBER 18, 2006

Vote on Motion: Mr. Bates YES, Mr. Glancy YES and Mr. Piros YES.

YES 3

NAY 0

Motion Carried.

296-06 Motion by Mr. Piros, seconded by Mr. Glancy to approve the minutes of the December 04th meeting.

Vote on Motion: Mr. Bates YES, Mr. Glancy YES and Mr. Piros YES.

YES 3

NAY 0

Motion Carried.

The following correspondence was read by Martha Urchek:

1. Contribution form from Tod Children's Hospital.
2. Set memo to Department Heads and Trustees setting cut off date for all departmental spending for December 20th, last date for invoices to be paid is December 21st and final day for receipting money will be December 28th and to close all purchase orders and blanket certificates and to reopen new ones (if necessary) on January 01, 2007.
3. Letter from Public Entity Risk Services of Ohio (PERSO) on the claim for the damaged fence at Hillside Cemetery due to high winds on December 01st.
4. Copied December Grassroots Clippings to trustees. In this newsletter standard mileage rates for the uses of a car will be 48.5 cents per mile effective January 01, 2007.
5. Emails from Darlene St. George on Weekly Updates from Ohio Township Association.
6. Letter from Attorney Finamore on the Township's Year-end and Re-organization Meetings Check List
7. Meeting Agenda for Board of Health Meeting on December 20th and minutes from their November 15th meeting.
8. Letter from 717 Credit Union informing us that tellers are coming to the Cortland Branch lobby.

DECEMBER 18, 2006

9. Invitation from the Cortland Trinity Daycare who will be singing at the Bazetta Police Station on December 20th at 11 AM. The public is also invited.

10. News Release from ODOT accepting applications for safe routes to school projects.

297-06 Motion by Mr. Piros, seconded by Mr. Glancy to approve purchase orders.

Vote on Motion: Mr. Bates YES, Mr. Glancy YES and Mr. Piros YES.

YES 3

NAY 0

Motion Carried.

Mr. Glancy asked if he could make a comment on the correspondence in regard to the News Release from ODOT safe school routes. He informed the public that there is a path from Bazetta Elementary School to Candlelight Knolls in care of a tragedy at the school.

Chief Sayers said there is a new House Bill for a school safety plan and he is working on it.

298-06 Motion by Mr. Bates, seconded by Mr. Glancy to approve payment of bills.

Vote on Motion: Mr. Bates YES, Mr. Glancy YES and Mr. Piros YES.

YES 3

NAY 0

Motion Carried.

Road Superintendent Parke:

Mr. Parke said he and Mr. Bates took a truck ride along the Mackey property and both agreed that it is not the limbs, but the tree trunk that is the problem. After much discussion, Mr. Bates and Mr. Parke will talk with Mrs. Mackey and let her know that the tree must be cut down and the township will plant another tree closer to the house.

Mr. Finamore asked Mr. Mauger since this is a corner lot, does the township have a triangle rule and the reply was he will check into this.

Mr. Parke asked if a street light could be moved from the curve of McCleary Jacoby and State Route 46 to the entrance of Stonegate. Mr. Piros asked Mr. Parke to give him the tag number on the pole and he will contact Mr. O'Brian of Ohio Edison.

Mr. Parke said to be in compliance with grants, some employees need to complete NIMS 700 Series. Mr. Glancy and Martha will complete this before the end of the year.

DECEMBER 18, 2006

Mr. Parke said his department cleaned out the ditch on Howland Wilson Road and received an "adda boy" and they are cold patching some of the roads like Durst Clagg.

Mr. Glancy asked Mr. Parke about the letter on septic draining to ditches and asked who is to check to see if this is properly being done. Mr. Finamore said the township gives the approval for drainage, but the Health Department is responsible. The township is not accountable.

Police Chief Sayers:

Police Chief Sayers asked the Board to adopt the Mutual Aid Agreement. Mr. Piros asked if this agreement could be altered and the reply was no. This was tabled for a work session in January.

Fire Chief McKenzie:

Chief McKenzie had nothing to report.

Mr. Bates asked if the house on McCleary Jacoby Road is scheduled to be burned and the reply was his department will have live training to burn this house on Friday, December 22nd at 9 AM and by 11:30 AM it should be in the cellar. Mr. Bates asked if the neighboring residents were notified and the reply was yes by the EPA.

Chief McKenzie said he received a phone call from the State Park today asking if we could burn one of their rental houses on State Route 46 near St. Robert's Church as the State can no longer have rentals. After looking at the house, all the State Park wanted was the roof burned as it is a brick house. Chief McKenzie declined due to all the paperwork involved with the EPA. The State will demolish the house instead.

Zoning Inspector Mauger:

Mr. Mauger reported that he and Bud Rodgers from Bud's Towing will go to the Medzie property along with a police escort at 9 AM on Thursday, December 21st. Mr. Rodgers said it would cost approximately \$100 per car to haul them away.

Mr. Glancy asked Mr. Mauger if he has a tax map. At this time, Mr. Parke showed the Board the tax map and there are three trailers along with a house and we should be certain that the junk cars are on the Medzie property in question. Mr. Finamore will research this on Wednesday and will get back with Mr. Mauger.

Safety Committee:

Chief McKenzie gave his report earlier on the ladder for the police department.

DECEMBER 18, 2006**Administration:**

There was a reminder of the End of the Year Meeting at 9 AM on December 28th at the administration building and the Re-Organizational Meeting on January 02, 2007 at 8 AM at the administration building.

299-06 Motion by Mr. Bates, seconded by Mr. Glancy to accept the inventories of the Administration, Cemetery, Maintenance, Park, Road and Fire Departments.

Vote on Motion: Mr. Bates YES, Mr. Glancy YES and Mr. Piros YES.

YES 3

NAY 0

Motion Carried.

300-06 Motion by Mr. Piros, seconded by Mr. Glancy to authorize the Fiscal Officer to request an Advance of 1st Half Settlement of 2006 Personal Property Tax from the Trumbull County Auditor.

Vote on Motion: Mr. Bates YES, Mr. Glancy YES and Mr. Piros YES.

YES 3

NAY 0

Motion Carried.

301-06 Motion by Mr. Glancy, seconded by Mr. Piros to authorize the Fiscal Officer to request an Advance of 1st Half Settlement of 2006 Real Estate Tax from the Trumbull County Auditor.

Vote on Motion: Mr. Bates YES, Mr. Glancy YES and Mr. Piros YES.

YES 3

NAY 0

Motion Carried.

302-06 Motion by Mr. Piros, seconded by Mr. Glancy to authorize the Fiscal Officer to request an Advance 1st Half Settlement of 2006 Inheritance Tax from the Trumbull County Auditor.

Vote on Motion: Mr. Bates YES, Mr. Glancy YES and Mr. Piros YES.

YES 3

NAY 0

Motion Carried.

A work session was set for December 28th with the department heads on the 2007 Budget following the End of the Year Meeting.

DECEMBER 18, 2006

303-06 Motion by Mr. Glancy, seconded Mr. Piros to accept the Annual ODOT Mileage Certification of 19.91 miles for the township.

Vote on Motion: Mr. Bates YES, Mr. Glancy YES and Mr. Piros YES.

YES 3

NAY 0

Motion Carried.

Mr. Piros asked Mr. Parke if he had talked with Mike Sliwinski on Art Racco's Lakeshore Drive property and the report will be forthcoming.

The "No Smoking Ban" was tabled.

304-06 Motion by Mr. Glancy, seconded by Mr. Piros to appoint the following people on the Volunteer Fire Fighter's Dependents Fund Board for 2007:

Mike Mannella, Chairman
Tom Rink, Secretary
Kevin Lesh

Elliott Fike
Donald Murphy

Vote on Motion: Mr. Bates YES, Mr. Glancy YES and Mr. Piros YES.

YES 3

NAY 0

Motion Carried.

305-06 Motion by Mr. Bates, seconded by Mr. Glancy to go into executive session at 7:50 PM to discuss a grievance.

Vote on Motion: Mr. Bates YES, Mr. Glancy YES and Mr. Piros YES.

YES 3

NAY 0

Motion Carried.

306-06 Motion by Mr. Bates, seconded by Mr. Glancy to return to regular session at 8:15 PM.

Vote on Motion: Mr. Bates YES, Mr. Glancy YES and Mr. Piros YES.

YES 3

NAY 0

Motion Carried.

DECEMBER 18, 2006

307-06 Motion by Mr. Bates, seconded by Mr. Piros to adjourn the meeting at 8:20 PM.
Vote on Motion: Mr. Bates YES, Mr. Glancy YES and Mr. Piros YES.

YES 3

NAY 0

Motion Carried.

By Motion Adjourned:

A large, stylized handwritten signature in black ink, likely belonging to Mr. Piros, is written over the text "By Motion Adjourned:". The signature is highly cursive and spans across the width of the page.

**END OF THE YEAR SPECIAL MEETING MINUTES
DECEMBER 28, 2006
9:00 AM**

Present: Trustees Mike Piros, Bill Glancy and Jeff Bates.

This meeting was called to order by Chairman Jeff Bates.

308-06 Motion by Mr. Bates, seconded by Mr. Piros to authorize the Fiscal Officer to transfer within funds the following;

10-A-01 (Fire F.T. Salaries) To 10-A-02 (Fire Employer's Retire. Cont.)
\$8,209.56

10-A-01A (Fire P.T. Salaries) To 10-A-02 (Fire Employer's Retire. Cont.)
\$1,190.57

13-A-03 (Zoning Supplies) To 13-A-01 (Zoning Salaries)
\$288.45

09-A-01 (Police Salaries) To 09-A-01B (Police P.T. Salaries)
\$2,000.00

05-A-03 (Cemetery Employer's Retire. Cont.) To 05-A-01 (Salaries-Mowing)
\$403.77

Vote on Motion: Mr. Bates YES, Mr. Glancy YES and Mr. Piros YES.

YES 3

NAY 0

Motion Carried.

309-06 Motion by Mr. Glancy, seconded by Mr. Bates to approve the 2007 Temporary Appropriations for all necessary monies for the township expenses pending final appropriations.

Vote on Motion: Mr. Bates YES, Mr. Glancy YES and Mr. Piros YES.

YES 3

NAY 0

Motion Carried.

310-06 Motion by Mr. Piros, seconded by Mr. Bates to accept the police inventory.

Vote on Motion: Mr. Bates YES, Mr. Glancy YES and Mr. Piros YES.

YES 3

NAY 0

Motion Carried.

DECEMBER 28, 2006

311-06 Motion by Mr. Piros, seconded by Mr. Bates to adjourn the meeting at 9:30 AM.
Vote on Motion: Mr. Bates YES, Mr. Glancy YES and Mr. Piros YES.

YES 3
NAY 0
Motion Carried.

ATTEST

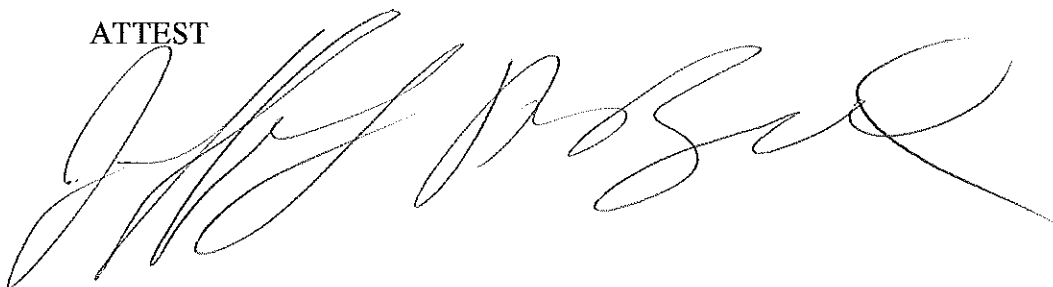
A large, stylized handwritten signature in black ink, likely belonging to a witness or official, positioned below the 'ATTEST' text.

2007 TEMPORARY APPROPRIATIONS

GENERAL: 01-A		
01-A-01	SALARIES-TRUSTEES	\$ 17,500.00
01-A-02	SALARY-FISCAL OFFICER	\$ 10,000.00
01-A-03	TRAVEL & OTHER EXPENSES	\$ 2,500.00
01-A-04	SUPPLIES - ADMINISTRATION	\$ 3,750.00
01-A-05	EQUIPMENT - ADMINISTRATION	\$ 1,750.00
01-A-06	INSURANCE	\$ 30,000.00
01-A-10	LEGAL COUNSEL	\$ 17,500.00
01-A-12	EMPLOYER'S RETIREMENT CONTRIBUTION	\$ 20,000.00
01-A-15	WORKMEN'S COMPENSATION	\$ 6,000.00
01-A-15A	UNEMPLOYMENT COMPENSATION	\$ -
01-A-16	GENERAL HEALTH DISTRICT	\$ 10,000.00
01-A-17	AUDITOR'S & TREASURER'S FEE	\$ 2,500.00
01-A-18	ADVERTISING DELINQUENT LANDS	\$ 250.00
01-A-19	STATE EXAMINERS' CHARGE	\$ -
01-A-21	ELECTION EXPENSES	\$ 2,500.00
01-A-22	CONDEMNED PROPERTY	\$ -
01-A-25	CONTINGENCY ACCOUNT	\$ -
01-A-26	OTHER EXPENSES	\$ 25,000.00
01-A-27	TRANSFERS	\$ 22,500.00
01-A-28	SECRETARY/CLERICAL STAFF SALARY	\$ 30,000.00
01-A-29	CONTRACTS	\$ 10,000.00
01-A-90	FICA/MEDICARE - EMPLOYER'S SHARE	\$ 2,000.00

TOTAL - 01-A	\$ 213,750.00
---------------------	----------------------

GENERAL: 01-B - TOWN HALL, MEMORIAL BUILDINGS & GROUNDS		
01-B-01	SALARIES	\$ 3,000.00
01-B-02	IMPROVEMENT OF SITES	\$ 500.00
01-B-03	NEW BUILDINGS & ADDITIONS	\$ -
01-B-04	UTILITIES - ADMINISTRATION BUILDING	\$ 7,500.00
01-B-05	MAINTENANCE, SUPPLIES & MATERIALS	\$ -
01-B-06	EQUIPMENT PURCHASES & REPLACEMENT	\$ -
01-B-07	REPAIRS	\$ -
01-B-08	OTHER EXPENSES	\$ -

TOTAL - 01-B	\$ 11,000.00
---------------------	---------------------

GENERAL: 01-C- FIRE PROTECTION		
01-C-02	EQUIPMENT PURCHASES & REPLACEMENT	\$ -
01-C-03	UTILITIES - FIRE	\$ 10,000.00
01-C-07	REPAIRS - FIRE	\$ -
		\$ -

TOTAL - 01-C	\$ 10,000.00
---------------------	---------------------

GENERAL: 01-D - UNION CEMETERY		
01-D-08	CEMETERY EXPENSES	\$ -

TOTAL 01-D	\$ -
-------------------	-------------

GENERAL: 01-E - STREET LIGHTS

01-E-01	STREET LIGHT CONTRACTS	\$	1,500.00
01-E-03	STREET LIGHT OTHER	\$	-

TOTAL - 01-E		\$	1,500.00
---------------------	--	-----------	-----------------

GENERAL: 01-F - PARK & IMAGINATION STATION

01-F-01	SALARIES - MECHANIC	\$	500.00
01-F-01-A	SALARIES - GROUNDSKEEPER	\$	3,000.00
01-F-02	IMPROVEMENT OF SITES	\$	6,250.00
01-F-04	NEW BUILDINGS & ADDITIONS	\$	-
01-F-04-A	NEW BUILDINGS - IMAGINATION STATION	\$	-
01-F-05	NEW TOOLS & EQUIPMENT	\$	-
01-F-06	SUPPLIES - PARK	\$	1,250.00
01-F-07	REPAIRS & MAINTENANCE - PARK	\$	250.00
01-F-08	OTHER EXPENSES	\$	250.00
01-F-09	SPECIALS EVENTS AT PARK	\$	500.00

TOTAL - 01-F		\$	12,000.00
---------------------	--	-----------	------------------

GENERAL: 01-G - POLICE PROTECTION

01-G-02	EQUIPMENT & REPLACEMENT	\$	-
01-G-03	UTILITIES - POLICE	\$	10,000.00
		\$	-

TOTAL - 01-G		\$	10,000.00
---------------------	--	-----------	------------------

GENERAL: 01-H - CONTRACTS

01-H-06	CONTRACTS	\$	1,000.00
---------	-----------	----	----------

TOTAL - 01-H		\$	1,000.00
---------------------	--	-----------	-----------------

GENERAL: 01-K - HIGHWAY MAINTENANCE

01-K-09	UTILITIES - ROAD	\$	5,000.00
---------	------------------	----	----------

TOTAL - 01-K		\$	5,000.00
---------------------	--	-----------	-----------------

GENERAL: 01-M - ROAD

01-M-03	CONTRACTS - PAVING	\$	5,000.00
---------	--------------------	----	----------

TOTAL - 01-M		\$	5,000.00
---------------------	--	-----------	-----------------

GENERAL: 01-N - ADVANCES OUT

01-N-01	ADVANCES OUT	\$	-
---------	--------------	----	---

TOTAL - 01-N			
---------------------	--	--	--

MOTOR VEHICLE: 02

02-B-02	MATERIALS - SALT - SAND	\$	13,000.00
02-B-03	CONTRACTS	\$	-
02-B-04	OTHER EXPENSES		

TOTAL - 02		\$	13,000.00
-------------------	--	----	------------------

GASOLINE TAX: 03-A, 03-B AND 03-C

03-A-03	WORKERS COMPENSATION		0
03-A-04	TOOLS & EQUIPMENT	\$	13,750.00
03-A-05	SUPPLIES	\$	11,250.00
03-A-06	REPAIRS	\$	11,250.00
03-A-07	MAINTENANCE OF EQUIPMENT	\$	11,250.00
03-B-02	MATERIAL	\$	11,250.00
03-B-04	OTHER EXPENSES	\$	9,000.00
03-C-03	CONTRACTS	\$	7,500.00

TOTAL - 03		\$	75,250.00
-------------------	--	----	------------------

ROADS & BRIDGES: 04-A, 04-B AND 04-C

04-A-02	EMPLOYER'S RETIREMENT CONTRIBUTION	\$	10,000.00
04-A-03	WORKMEN'S COMPENSATION	\$	2,850.00
04-A-04	TOOLS & EQUIPMENT	\$	250.00
04-A-05	SUPPLIES	\$	1,000.00
04-A-06	REPAIRS	\$	-
04-A-07	MAINTENANCE OF EQUIPMENT	\$	-
04-A-08	BUILDINGS & ADDITIONS	\$	-
04-A-10	INSURANCE	\$	38,000.00
04-A-13	OTHER EXPENSES	\$	-
04-A-14	TRANSFERS	\$	-
04-A-15	AUDITOR'S & TREASURER'S FEES	\$	1,750.00
04-A-90	FICA/MEDICARE - EMPLOYER'S SHARE	\$	750.00
04-B-01	SALARIES	\$	71,500.00
04-B-02	MATERIAL	\$	-
04-B-03	CONTRACTS	\$	1,000.00
04-B-04	OTHER EXPENSES - MAINTENANCE	\$	-
04-C-03	CONTRACTS	\$	-
04-C-04	OTHER EXPENSES	\$	-

TOTAL - 04-A, 04-B AND 04-C		\$	127,100.00
------------------------------------	--	----	-------------------

CEMETERY: 05		
05-A-01	SALARIES - MOWING	\$ 8,000.00
05-A-02	SALARIES - BURIALS & CEMETERY SEXTON	\$ 4,000.00
05-A-02-A	SALARIES - CLERICAL	\$ 2,000.00
05-A-03	EMPLOYER'S RETIREMENT CONTRIBUTION	\$ 1,500.00
05-A-04	WORKMEN'S COMPENSATION	\$ 925.00
05-A-05	IMPROVEMENT OF SITES	\$ -
05-A-06	LAND PURCHASES	\$ -
05-A-07	REPAIRS & MAINTENANCE	\$ 500.00
05-A-08	TOOLS & EQUIPMENT	\$ 250.00
05-A-09	SUPPLIES	\$ 900.00
05-A-12	OTHER EXPENSES	\$ 250.00
05-A-12A	INSURANCE	\$ 900.00
05-A-13	UNEMPLOYMENT COMPENSATION	\$ 2,100.00
05-A-90	FICA/MEDICARE - EMPLOYER'S SHARE	\$ 250.00
TOTAL - 05		\$ 21,575.00

CEMETERY BEQUEST: 06		
06-A-01	EXPENDITURES - NON-RESTRICTED	\$ 2,000.00
TOTAL - 06		\$ 2,000.00

LIGHTING ASSESSMENT - IVY HILL: 07		
07-A-01	LIGHTING CONTRACTS	\$ 1,440.00
07A-02	OTHER EXPENSES (SALARY / AUDITOR FEES/MISC.)	\$ 50.00
TOTAL - 07		\$ 1,490.00

LIGHTING ASSESSMENT - MORROW & WILLIAMS DRIVES: 07-A		
07-A-01-A	LIGHTING CONTRACTS	\$ 1,215.00
07-A-02-A	OTHER EXPENSES (SALARY / AUDITOR FEES/MISC.)	\$ 50.00
TOTAL - 07-A		\$ 1,265.00

LIGHTING ASSESSMENT - TIMBER CREEK HEIGHTS: 07-B		
07-A-01-B	LIGHTING CONTRACTS	\$ 786.00
07-A-02-B	OTHER EXPENSES (SALARY / AUDITOR FEES, MISC.)	\$ 50.00
TOTAL - 07-B		\$ 836.00

LIGHTING ASSESSMENT - TIMBER CREEK ESTATES: 07-C		
07-A-01-C	LIGHTING CONTRACTS	\$ 2,832.00
07-A-02-C	OTHER EXPENSES (SALARY / AUDITOR FEES, MISC.)	\$ 50.00
TOTAL - 07-C		\$ 2,882.00

POLICE DISTRICT: 09		
09-A-01	SALARIES (FULL TIME)	\$ 151,000.00
09-A-01-A	SALARIES - OVERTIME (FULL TIME)	\$ 25,000.00
09-A-01-B	SALARIES - (PART TIME)	\$ 27,900.00
09-A-01D	SALARIES - MECHANIC	\$ 4,450.00
09-A-02	EMPLOYER'S RETIREMENT CONTRIBUTION	\$ 43,880.00
09-A-03	WORKMEN'S COMPENSATION	\$ 8,797.00
09-A-04	AUDITOR'S & TREASURER'S FEES	\$ 5,000.00
09-A-07	TOOLS & EQUIPMENT	\$ 10,000.00
09-A-08	SUPPLIES	\$ 8,000.00
09-A-09	BUILDING IMPROVEMENTS	\$ -
09-A-10	CONTRACTS	\$ 20,000.00
09-A-12	INSURANCE	\$ 57,000.00
09-A-12-A	TRANSFERS	\$ -
09-A-13	TRAINING	\$ 3,000.00
09-A-14	OTHER EXPENSES	\$ 77,800.00
09-A-15-A	UNEMPLOYMENT COMPENSATION	\$ -
09-A-90	FICA/MEDICARE - EMPLOYER'S SHARE	\$ 3,000.00

TOTAL - 09		\$ 444,827.00
-------------------	--	----------------------

POLICE DISTRICT EQUIPMENT: 09-C		
09-A-04-C	TOOLS & EQUIPMENT	\$ 18,000.00
09-A-05-C	SUPPLIES	\$ 11,000.00
09-A-06-C	REPAIRS	\$ 8,000.00
09-A-08-C	AUDITOR'S & TREASURER'S FEES	\$ 450.00
09-A-10-C	CONTRACTS	\$ -

TOTAL - 09-C		\$ 37,450.00
---------------------	--	---------------------

POLICE - O.M.V.I.: 09-J		
09-A-14J	OMVI	\$ 150.00

TOTAL - 09-J		\$ 150.00
---------------------	--	------------------

FIRE DISTRICT: 10-A & 10-C		
10-A-01	SALARIES (FULL TIME)	\$ 225,000.00
10-A-01-A	SALARIES (PART TIME)	\$ 80,000.00
10-A-01-B	SALARY - MECHANIC	\$ 4,000.00
10-A-02	EMPLOYER'S RETIREMENT CONTRIBUTION	\$ 63,500.00
10-A-03	WORKMEN'S COMPENSATION	\$ 16,600.00
10-A-04	AUDITOR'S & TREASURER'S FEES	\$ 6,000.00
10-A-06	NEW BUILDINGS & EQUIPMENT	\$ -
10-A-07	UTILITIES	\$ 3,500.00
10-A-08	TOOLS & EQUIPMENT	\$ 41,620.00
10-A-09	SUPPLIES	\$ 7,500.00
10-A-10	REPAIRS	\$ 5,000.00
10-A-11	TRAINING	\$ 2,500.00
10-A-14	INSURANCE	\$ 73,500.00
10-A-14-A	CONTRACTS	\$ 1,000.00
10-A-15	OTHER EXPENSES	\$ 250.00
10-A-17	TRANSFERS	\$ -
10-A-90	FICA/MEDICARE - EMPLOYER'S SHARE	\$ 12,500.00
10-C-05	EMS - SUPPLIES	\$ 5,000.00
10-C-06	EMS - REPAIRS	\$ 2,500.00
10-C-07	EMS - CONTRACTS	\$ 11,000.00
10-C-08	EMS - OTHER EXPENSES	\$ 2,500.00

TOTAL - 10-A & 10-C	\$ 563,470.00
--------------------------------	----------------------

ZONING: 13		
13-A-01	SALARIES & FEES	\$ 4,728.00
13-A-02	OTHER EXPENSES	\$ 1,500.00
13-A-03	SUPPLIES	\$ 500.00

TOTAL - 13	\$ 6,728.00
-------------------	--------------------

FIREFIGHTERS ASSISTANCE: 14		
14-A-07	TOOLS & EQUIPMENT	\$ 500.00

TOTAL - 14	\$ 500.00
-------------------	------------------

FEMA: 14-A		
14-A-07-A	EXPENDITURES - REIMBURSEMENTS	\$ -

TOTAL - 14-A	\$ -
---------------------	-------------

GENERAL BOND / NOTE RETIREMENT: 15

15-A-01	FIRE EQUIPMENT (PRINCIPLE & INTEREST)	\$	32,000.00
15-A-01-A	ROAD EQUIPMENT (PRINCIPLE & INTEREST)	\$	-
15-A-01-B	POLICE EQUIPMENT (PRINCIPLE & INTEREST)	\$	25,000.00
15-A-04	INTEREST	\$	6.27

TOTAL - 15		\$	57,006.27
-------------------	--	----	------------------

DRUG ENFORCEMENT: 22

22-A-01	DRUG ENFORCEMENT	\$	436.00
---------	------------------	----	--------

TOTAL - 22		\$	436.00
-------------------	--	----	---------------

PERMISSIVE LICENSE PLATE TAX: 23

23-A-90	FICA/MEDICARE - EMPLOYER'S SHARE	\$	-
---------	----------------------------------	----	---

TOTAL - 23		\$	-
-------------------	--	----	----------

PERMANENT IMPROVEMENT: 26

26-A-06	SUPPLIES	\$	-
---------	----------	----	---

TOTAL - 26		\$	-
-------------------	--	----	----------

ISSUE II - IMPROVEMENT: 30

30-A-05-A	CAPITAL EXPENDITURES - TOWNSHIP	\$	-
30-A-06	CAPITAL EXPENDDITURES - O.P.W.C.	\$	-
30-A-09	OTHER EXPENSES	\$	-

TOTAL - 30		\$	-
-------------------	--	----	----------

RECAPITULATION OF FUNDS - 2007

FUND 01	GENERAL: 01-A	\$ 213,750.00
	GENERAL: 01-B - TOWN HALL, MEMORIAL BUILDINGS & GROUNDS	\$ 11,000.00
	GENERAL: 01-C - FIRE PROTECTION	\$ 10,000.00
	GENERAL: 01-D - UNION CEMETERY	\$ -
	GENERAL: 01-E - STREET LIGHTS	\$ 1,500.00
	GENERAL: 01-F - PARK & IMAGINATION STATION	\$ 12,000.00
	GENERAL: 01-G - POLICE PROTECTION	\$ 10,000.00
	GENERAL: 01-H - CONTRACTS	\$ 1,000.00
	GENERAL: 01-K - HIGHWAY MAINTENANCE	\$ 5,000.00
	GENERAL: 01-M - ROAD	\$ 5,000.00
	GENERAL: 01-N - ADVANCES OUT	\$ -
	TOTAL - GENERAL FUND 01	\$ 269,250.00

FUND 02	MOTOR VEHICLE: 02	\$ 13,000.00
FUND 03	GASOLINE TAX: 03-A, 03-B AND 03-C	\$ 75,250.00
FUND 04	ROADS & BRIDGES: 04-A, 04-B AND 04-C	\$ 127,100.00
FUND 05	CEMETERY: 05	\$ 21,575.00
FUND 06	CEMETERY BEQUEST: 06	\$ 2,000.00
FUND 07	LIGHTING ASSESSMENT - IVY HILL: 07	\$ 1,490.00
FUND 07-A	LIGHTING ASSESSMENT - MORROW & WILLIAMS DRIVES: 07-A	\$ 1,265.00
FUND 07-B	LIGHTING ASSESSMENT - TIMBER CREEK HEIGHTS: 07-B	\$ 836.00
FUND 07-C	LIGHTING ASSESSMENT - TIMBER CREEK ESTATES: 07-C	\$ 2,882.00
FUND 09	POLICE DISTRICT: 09	\$ 444,827.00
FUND 09-C	POLICE DISTRICT EQUIPMENT: 09-C	\$ 37,450.00
FUNB 09-J	POLICE - O.M.V.I.: 09-J	\$ 150.00
FUND 10	FIRE DISTRICT: 10-A & 10-C	\$ 563,470.00
FUND 13	ZONING: 13	\$ 6,728.00
FUND 14	FIREFIGHTERS ASSISTANCE: 14	\$ 500.00
FUND 14-A	FEMA: 14-A	\$ -
FUND 15	GENERAL BOND / NOTE RETIREMENT: 15	\$ 57,006.27
FUND 22	DRUG ENFORCEMENT: 22	\$ 436.00
FUND 23	PERMISSIVE LICENSE PLATE TAX: 23	\$ -
FUND 26	PERMANENT IMPROVEMENT: 26	\$ -
FUND 30	ISSUE II - IMPROVEMENT: 30	\$ -

TOTAL ALL FUNDS	\$ 1,625,215.27
------------------------	------------------------

\$ 1,625,215.27

2007 TEMPORARY APPROPRIATIONS
DECEMBER 28, 2006 - RESOLUTION #309-06

**WORK SESSION WITH FISCAL OFFICER, TRUSTEES AND DEPARTMENT
HEADS
DECEMBER 28, 2006 AT 9:30AM**

Present: Jeff Bates, Mike Piros, Bill Glancy, Martha Urchek, Chuck Sayers, Clyde McKenzie, and Kris Parke (sitting in for Frank Parke).

Discussion on:

- Fiscal Officer Martha Urchek passed out the 2007 Temporary Appropriations to the Department Heads.
- Discussed Permanent Appropriations due before March of 2007.
- Discussed ordering of office supplies for the township. Chuck Sayers suggested having a central location at the Police Station. He will co-ordinate with the other departments and will have more details on this at the next meeting.
- Mr. Bates is working on the township's cell phone agreement with Alltel and will have more information at our January meeting.
- Mr. Rentz's longevity was discussed with Chuck Sayers as to the correct date which is the full time date of September 24, 2006
- Discussed the Road Department employees charging time to the Fire and Police. Kris Parke will work up a time sheet so only inside work will be charged to these two departments, all outside work will be charged to Administration.

Meeting adjourned at 10:30 AM.

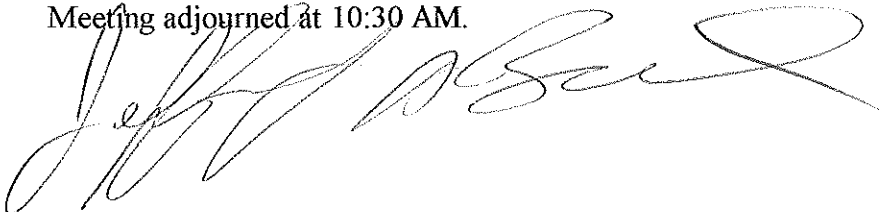
A large, stylized handwritten signature in black ink, appearing to read "Jeff Bates". The signature is written in a cursive, flowing style with a large loop at the end.

1

2

3

1

2